

INTERNATIONAL STANDARD

ISO
265-1

First edition
1988-12-15



INTERNATIONAL ORGANIZATION FOR STANDARDIZATION
ORGANISATION INTERNATIONALE DE NORMALISATION
МЕЖДУНАРОДНАЯ ОРГАНИЗАЦИЯ ПО СТАНДАРТИЗАЦИИ

Pipes and fittings of plastics materials — Fittings for domestic and industrial waste pipes — Basic dimensions: Metric series —

Part 1:

Unplasticized poly(vinyl chloride) (PVC-U)

iTeh STANDARD PREVIEW

(standards.iteh.ai)

ISO 265-1:1988

Tubes et raccords en matières plastiques — Raccords pour canalisations d'évacuations domestiques et industrielles — Dimensions de base: Série métrique —

Partie 1: Poly(chlorure de vinyle) non plastifié (PVC-U)

Foreword

ISO (the International Organization for Standardization) is a worldwide federation of national standards bodies (ISO member bodies). The work of preparing International Standards is normally carried out through ISO technical committees. Each member body interested in a subject for which a technical committee has been established has the right to be represented on that committee. International organizations, governmental and non-governmental, in liaison with ISO, also take part in the work. ISO collaborates closely with the International Electrotechnical Commission (IEC) on all matters of electrotechnical standardization.

Draft International Standards adopted by the technical committees are circulated to the member bodies for approval before their acceptance as International Standards by the ISO Council. They are approved in accordance with ISO procedures requiring at least 75 % approval by the member bodies voting.

International Standard ISO 265-1 was prepared by Technical Committee ISO/TC 138, *Plastics pipes, fittings and valves for the transport of fluids*. [ISO 265-1:1988](https://standards.iteh.ai/catalog/standards/sist/c1e668fc-0dca-4a2c-b0c7-4a01262cc938/iso-265-1-1988)

This first edition of ISO 265-1 cancels and replaces ISO/R 265 : 1962, the scope of which has been revised to apply to fittings with spigot ends, socket fittings, and socket fittings with curved (swept) entries made of unplasticized poly(vinyl chloride) (PVC-U).

Users should note that all International Standards undergo revision from time to time and that any reference made herein to any other International Standard implies its latest edition, unless otherwise stated.

Pipes and fittings of plastics materials — Fittings for domestic and industrial waste pipes — Basic dimensions: Metric series —

Part 1: Unplasticized poly(vinyl chloride) (PVC-U)

iTeh STANDARD PREVIEW (standards.iteh.ai)

1 Scope and field of application

This part of ISO 265 specifies the series of diameters and the formulae for calculation of the dimensions common to the main types of fittings with spigot ends, socket fittings, and socket fittings with curved (swept) entries of unplasticized poly(vinyl chloride) (PVC-U) for domestic and industrial waste pipes, regardless of the method of manufacture (with the exception of fittings fabricated from pipes) and of the composition.

It does not give all the dimensions which are required to manufacture the fittings. These dimensions will be the subject of future International Standards specifying the socket length, spigot length, etc.

It covers types and sizes of fittings and should be used as a guide for manufacturers and users, and as a basis for specific standards.

It may later be extended to include other types and sizes of fittings, when increasing use of plastics materials for piping makes this necessary.

Extension to include other types of fittings should be made by observing the principles laid down in this part of ISO 265.

The laying lengths (z lengths) given in this part of ISO 265 are intended to assist in the design of moulds, and are not intended to be used for quality control purposes.

NOTE — ISO 265-2 will deal with fittings made of other plastics materials.

2 References

ISO 161-1, *Thermoplastics pipes for the transport of fluids — Nominal outside diameters and nominal pressures — Part 1: Metric series.*

ISO 3633, *Unplasticized poly(vinyl chloride) (PVC-U) pipes and fittings for soil and waste discharge (low and high temperature) systems inside buildings — Specifications.*¹⁾

ISO 8283-1, *Plastics pipes and fittings — Dimensions of sockets and spigots for discharge systems inside buildings — Part 1: Unplasticized poly(vinyl chloride) (PVC-U) and chlorinated poly(vinyl chloride) (PVC-C).*¹⁾

1) At present at the stage of draft.

Section one: Socket fittings with spigot end

3 Scope

This section specifies the series of diameters and the dimensions common to the main types of fittings with spigot ends.

4 Diameters of fittings

The nominal diameters of a fitting correspond to and are designated by the nominal outside diameters of the pipes for which they are designed. In the case of reduced branches and reducers, the designation includes both diameters, the greater diameter at the spigot end being given first.

The nominal diameters of fittings shall be selected from the following values:

40 — 50 — 63 — 75 — 90 — 110 — 125 — 160 mm

However, if supplementary diameters should be necessary, these shall be taken from the diameter series given in ISO 161-1.

5 Angles

For elbows, the nominal angles (α) shall be 15°, 22 1/2°, 30°, 45°, 67 1/2° or 87 1/2° to 88 1/2°.

For branches and double branches, the nominal angles (α) shall be 45°, 67 1/2° or 87 1/2° to 88 1/2°.

6 Laying lengths

Laying lengths (z) are designated as follows:

"pipe to pipe": when the axes of the openings in the fitting concerned are parallel;

"pipe to axis": when the axes of the openings in the fitting are not parallel.

The z dimensions are given in clause 7.

The laying length on the socket side is defined as the distance between the point of intersection of the axes and the position taken up by the spigot when fully inserted into the socket.

The laying length on the spigot side is defined as the distance between the point of intersection of the axes and the position taken up by the mouth of the socket when the spigot is fully inserted into the socket.

The laying length of a fitting without any intersection of the axes is defined as the distance between the end of the spigot fully inserted into the socket of the fitting and the mouth of the socket into which the spigot end of the fitting is fully inserted.

The minimum laying lengths (z) shall be calculated using the formulae given in figures 1 to 4. As a guide, the z values given in tables 1 to 3 have been calculated using the series B wall thicknesses according to ISO 3633 and the angle $\beta = 15^\circ$. The z values for fittings of other wall thicknesses or angle β should be calculated similarly.

7 Dimensions of fittings

The various types of fittings are designated by their nominal diameters and angles given in tables 1, 2 and 3.

The figures given in this section cover the following fittings:

- elbows (figure 1);
- branches and double branches (figures 2 and 3);
- eccentric reducers (figure 4).

The values in tables 1, 2 and 3 have been rounded to the nearest whole number (values ending in ".5" have been rounded up).

Dimensions D and e_{\min} are in accordance with ISO 3633 and ISO 8283-1.

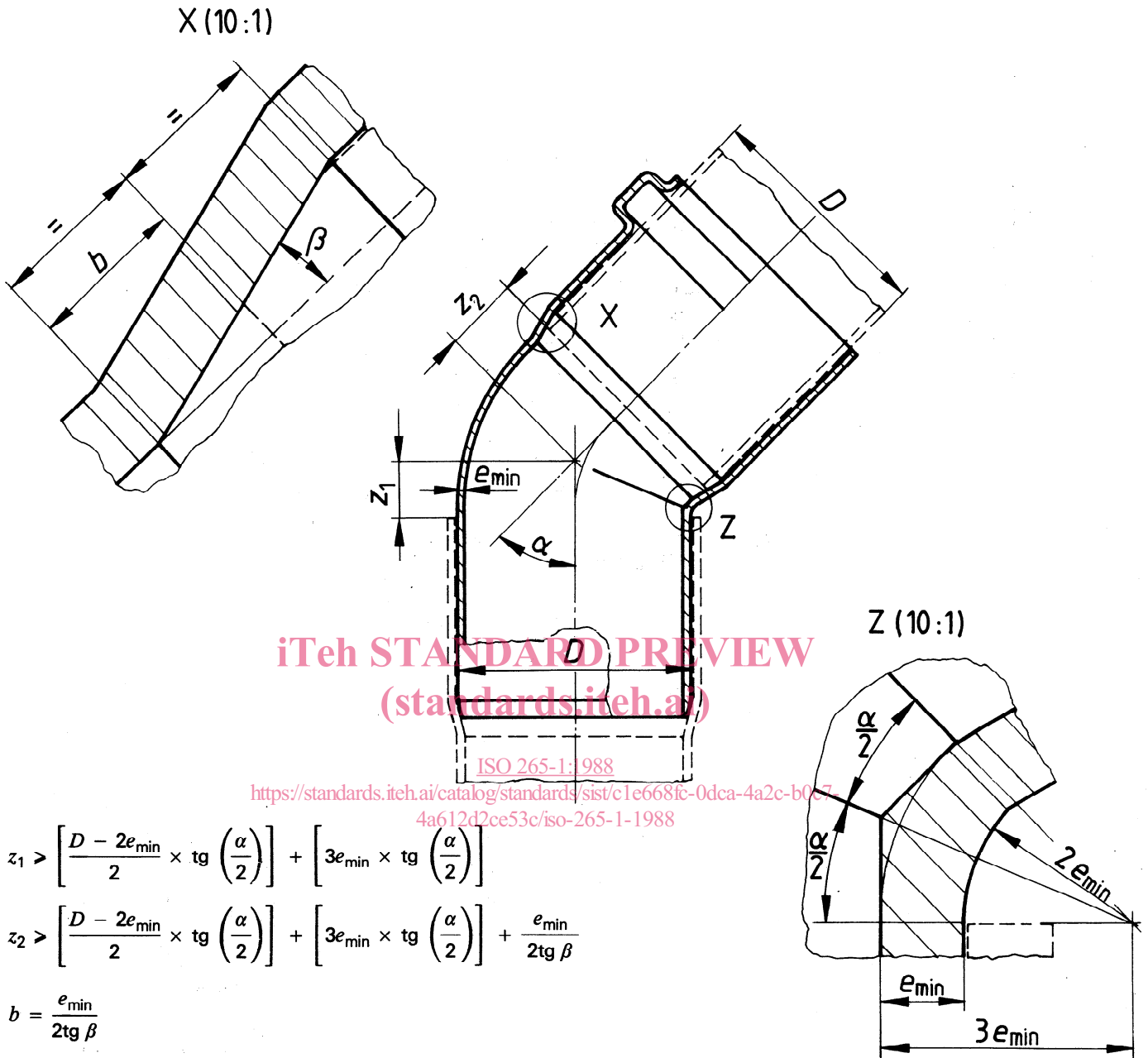

$$z_1 > \left[\frac{D - 2e_{\min}}{2} \times \operatorname{tg} \left(\frac{\alpha}{2} \right) \right] + \left[3e_{\min} \times \operatorname{tg} \left(\frac{\alpha}{2} \right) \right]$$

$$z_2 > \left[\frac{D - 2e_{\min}}{2} \times \operatorname{tg} \left(\frac{\alpha}{2} \right) \right] + \left[3e_{\min} \times \operatorname{tg} \left(\frac{\alpha}{2} \right) \right] + \frac{e_{\min}}{2 \operatorname{tg} \beta}$$

$$b = \frac{e_{\min}}{2 \operatorname{tg} \beta}$$

$$3e_{\min} \times \operatorname{tg} \left(\frac{\alpha}{2} \right) > 2 \text{ [mm]}$$

Figure 1 – Elbow with spigot end

Table 1 – Elbows with spigot end

Dimensions in millimetres

Nominal diameter <i>D</i>	Minimum laying lengths for nominal angle α											
	15°		22 1/2°		30°		45°		67 1/2°		87 1/2° to 88 1/2°	
	z_1	z_2	z_1	z_2	z_1	z_2	z_1	z_2	z_1	z_2	z_1	z_2
40	4	10	5	11	7	13	11	17	18	24	26	32
50	5	11	6	12	8	14	13	19	21	27	31	37
63	6	12	8	14	10	16	16	22	25	31	37	43
75	7	12	9	15	12	18	18	24	29	35	43	49
90	8	13	10	16	14	20	21	27	34	40	50	56
110	9	15	12	18	16	22	25	31	41	47	60	66
125	10	16	14	20	18	24	29	35	46	52	67	73
160	12	18	17	23	23	29	36	42	58	64	84	90

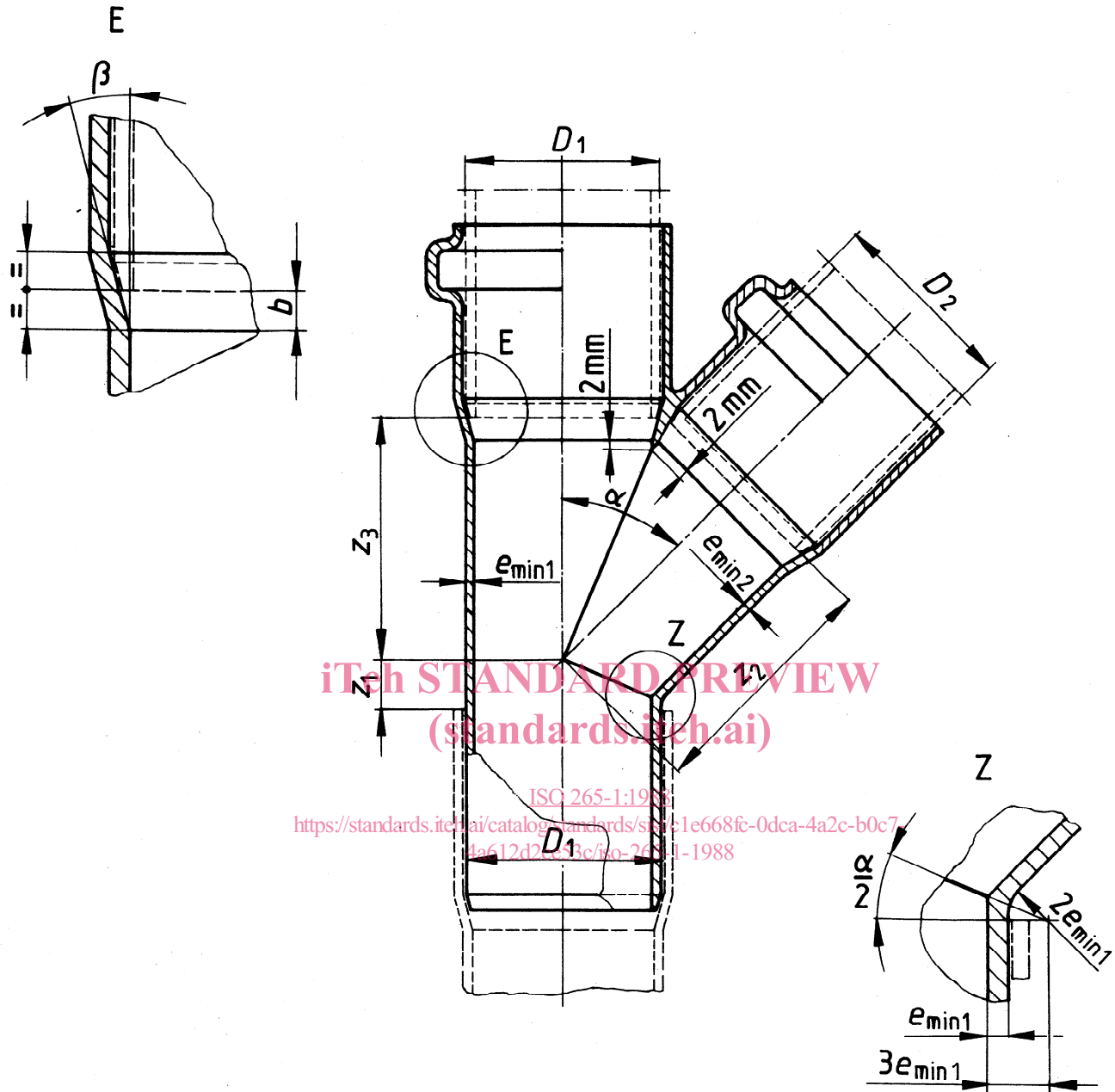

ISO 265-1:1988
<https://standards.itec.ai/catalog/standards/sstd/1e668fc-0dca-4a2c-b0c7-4a612d7c13c7/iso-265-1-1988>

$$z_1 > \frac{D_2 - 2e_{\min 2}}{2\sin \alpha} - \frac{D_1 - 2e_{\min 1}}{2\operatorname{tg} \alpha} + \left[3e_{\min 1} \times \operatorname{tg} \left(\frac{\alpha}{2} \right) \right]$$

$$z_2 > \frac{D_2 - 2e_{\min 2}}{2\operatorname{tg} \alpha} + \frac{D_1 - 2e_{\min 1}}{2\sin \alpha} + 2 + \frac{e_{\min 2}}{2\operatorname{tg} \beta}$$

$$z_3 > \frac{D_2 - 2e_{\min 2}}{2\sin \alpha} + \frac{D_1 - 2e_{\min 1}}{2\operatorname{tg} \alpha} + 2 + \frac{e_{\min 1}}{2\operatorname{tg} \beta}$$

$$b = \frac{e_{\min}}{2\operatorname{tg} \beta}$$

$$3e_{\min 1} \times \operatorname{tg} \left(\frac{\alpha}{2} \right) > 2 \text{ [mm]}$$

Figure 2 — Branch with spigot end

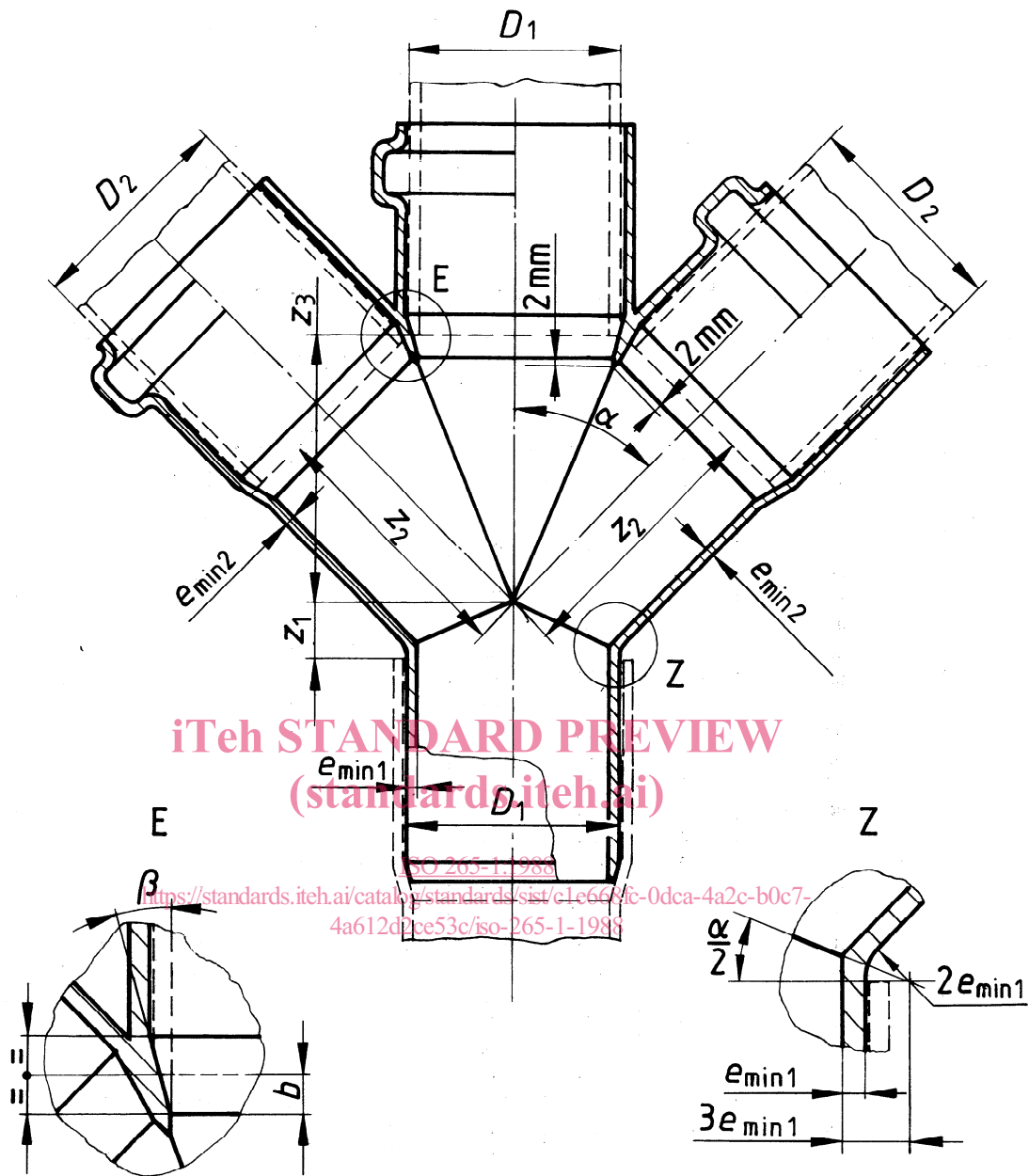

$$z_1 > \frac{D_2 - 2e_{\min 2}}{2 \sin \alpha} - \frac{D_1 - 2e_{\min 1}}{2 \operatorname{tg} \alpha} + \left[3e_{\min 1} \times \operatorname{tg} \left(\frac{\alpha}{2} \right) \right]$$

$$z_2 > \frac{D_2 - 2e_{\min 2}}{2 \operatorname{tg} \alpha} + \frac{D_1 - 2e_{\min 1}}{2 \sin \alpha} + 2 + \frac{e_{\min 2}}{2 \operatorname{tg} \beta}$$

$$z_3 > \frac{D_2 - 2e_{\min 2}}{2 \sin \alpha} + \frac{D_1 - 2e_{\min 1}}{2 \operatorname{tg} \alpha} + 2 + \frac{e_{\min 1}}{2 \operatorname{tg} \beta}$$

$$b = \frac{e_{\min}}{2 \operatorname{tg} \beta}$$

$$3e_{\min 1} \times \operatorname{tg} \left(\frac{\alpha}{2} \right) > 2 \text{ [mm]}$$

Figure 3 — Double branch with spigot end

Table 2 — Branches and double branches with spigot ends

Dimensions in millimetres

Nominal diameters		Minimum laying lengths for nominal angle α								
D_1	D_2	45°			67 1/2°			87 1/2° to 88 1/2°		
		z_1	z_2	z_3	z_1	z_2	z_3	z_1	z_2	z_3
40	40	11	49	49	18	33	33	26	25	25
50	40	6	56	54	16	39	35	26	30	25
50	50	13	61	61	21	41	41	31	30	30
63	40	- 1	65	60	13	46	38	25	37	26
63	50	7	70	67	18	48	43	30	37	31
63	63	16	76	76	25	50	50	37	37	37
75	40	- 7	73	66	10	52	40	25	43	26
75	50	1	78	73	16	54	46	30	43	31
75	63	10	85	82	23	57	53	37	43	37
75	75	18	91	91	29	59	59	43	43	43
90	50	7	89	81	13	62	49	30	50	31
90	63	2	95	90	20	65	56	37	51	37
90	75	11	101	98	26	67	62	43	51	43
90	90	21	109	109	34	71	71	50	51	51
110	40	-24	98	84	3	71	48	25	60	26
110	50	-17	103	89	9	73	53	30	60	31
110	63	- 8	110	100	16	76	60	36	61	38
110	75	1	116	108	22	78	67	42	61	44
110	90	11	123	119	30	81	75	50	61	51
110	110	25	133	133	41	85	85	60	61	61
125	50	-24	114	98	5	81	56	30	68	31
125	63	-15	120	107	12	84	63	36	68	38
125	75	- 7	126	116	19	86	70	42	68	44
125	90	4	134	126	27	89	78	50	68	51
125	110	18	144	141	38	94	89	60	69	61
125	125	29	151	151	46	97	97	67	69	69
160	75	-24	151	133	12	105	77	42	86	44
160	90	-14	158	144	20	108	85	49	86	52
160	110	0	168	158	31	113	96	59	86	62
160	125	11	176	169	39	116	104	67	86	69
160	160	36	193	193	58	123	123	84	87	87

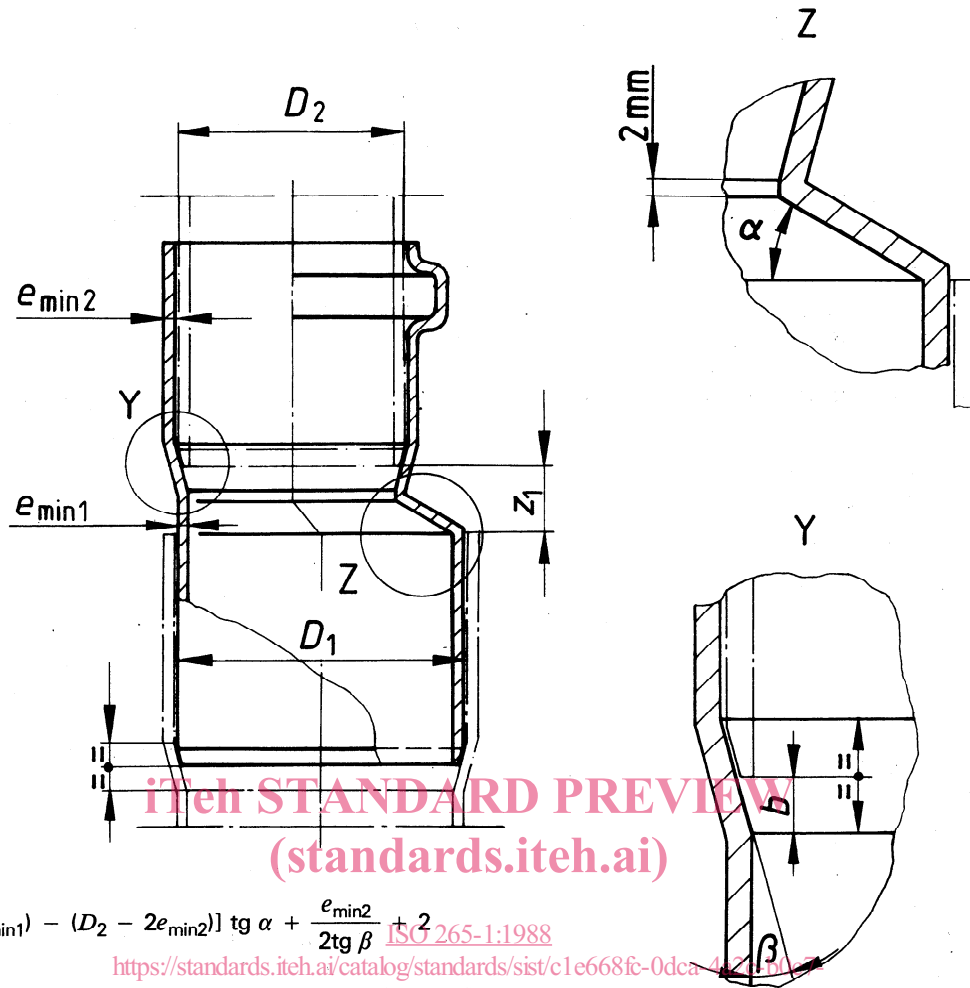

$$z_1 > [(D_1 - 2e_{\min 1}) - (D_2 - 2e_{\min 2})] \operatorname{tg} \alpha + \frac{e_{\min 2}}{2 \operatorname{tg} \beta} + 2$$

$$b = \frac{e_{\min 2}}{2 \operatorname{tg} \beta}$$

<https://standards.iteh.ai/catalog/standards/sist/c1e668fc-0dca-4424-b0e4-4a612d2ce53c/iso-265-1-1988>

Figure 4 – Eccentric reducer with spigot end

Table 3 – Eccentric reducers with spigot end

Dimensions in millimetres

Nominal diameters $D_1 \times D_2$	Minimum laying lengths z_1
50 × 40	14
63 × 40	21
63 × 50	15
75 × 40	28
75 × 50	22
75 × 63	15
90 × 50	31
90 × 63	24
90 × 75	17
110 × 50	43
110 × 63	35
110 × 75	28
110 × 90	20
125 × 75	37
125 × 90	28
125 × 100	17
160 × 110	37
160 × 125	28

NOTE — The values in this table have been calculated for $\alpha = 30^\circ$ and $\beta = 15^\circ$.

Section two: All-socket fittings

8 Scope

This section specifies the series of diameters and the dimensions common to the main types of socket fittings.

9 Diameters of fittings

The nominal diameters of a fitting correspond to and are designated by the nominal outside diameters of the pipes for which they are designed. In the case of reduced branches and reducers, the designation includes both diameters, the greater diameter being given first.

The nominal diameters of fittings shall be selected from the following values:

40 — 50 — 63 — 75 — 90 — 110 — 125 — 160 mm

However, if supplementary diameters should be necessary, these shall be taken from the diameter series given in ISO 161-1.

10 Angles

For elbows, the nominal angles (α) shall be 15°, 22 1/2°, 30°, 45°, 67 1/2° or 87 1/2° to 88 1/2°.

For branches and double branches, the nominal angles (α) shall be 45°, 67 1/2° or 87 1/2° to 88 1/2°.

11 Laying lengths

Laying lengths (z) are designated as follows:

“pipe to pipe”: when the axes of the openings in the fittings concerned are parallel;

“pipe to axis”: when the axes of the openings in the fittings are not parallel.

The z dimensions are given in clause 12.

The laying length is defined as the distance between the point of intersection of the axes and the position taken up by the end of the spigot when fully inserted into the socket.

The minimum laying lengths (z) shall be calculated using the formulae given in figures 5 and 6. As a guide, the z values given in tables 4 and 5 have been calculated using the series B wall thicknesses according to ISO 3633.

12 Dimensions of fittings

The various types of fittings are designated by their nominal diameters and angles given in tables 4 and 5.

The figures given in this section cover the following fittings:

— elbows (figure 5);
— branches (figure 6).

The values in the tables have been rounded to the nearest whole number (values ending in “,5” have been rounded up).

Dimensions D and e_{\min} are in accordance with ISO 3633 and ISO 8283-1.

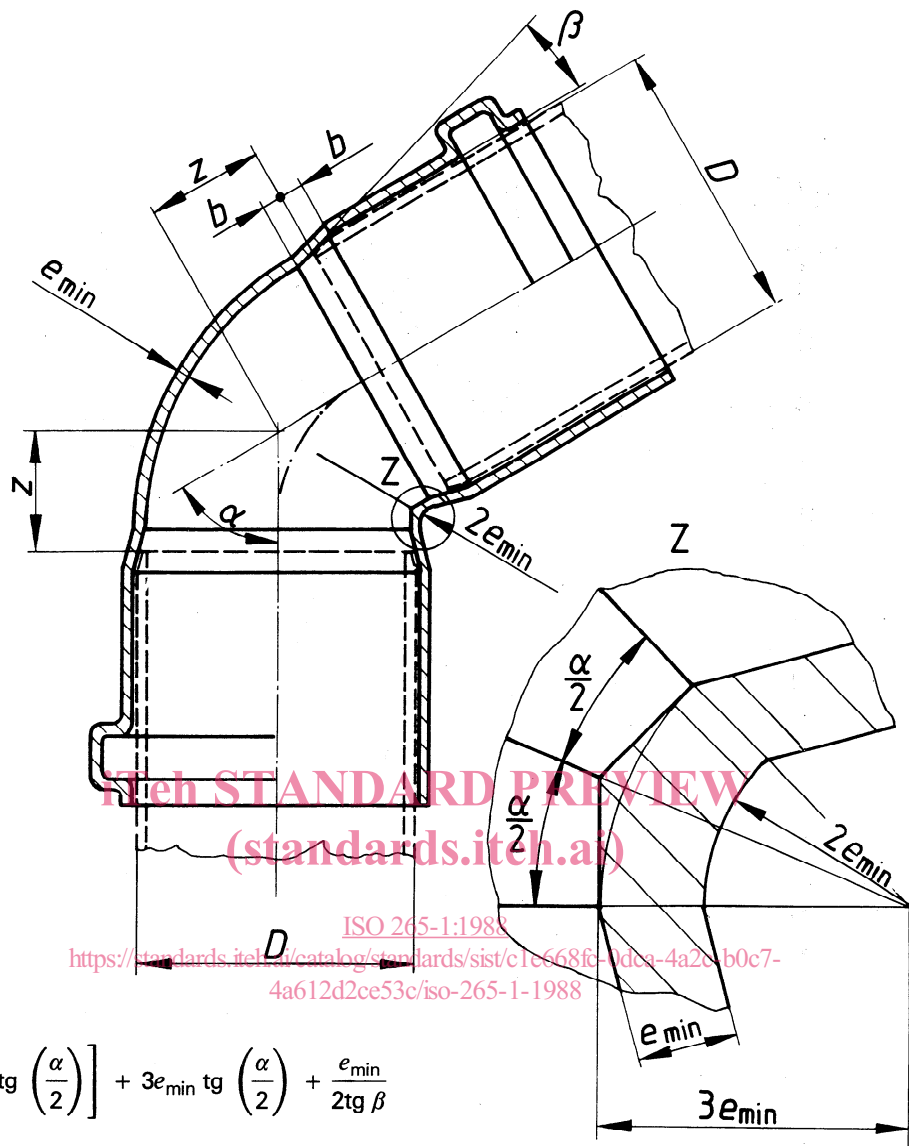

ISO 265-1:1988
<https://standards.iteh.ai/catalog/standards/sist/c1c668fc-9dca-4a2c-b0c7-4a612d2ce53c/iso-265-1-1988>

$$z > \left[\frac{D - 2e_{min}}{2} \times \operatorname{tg} \left(\frac{\alpha}{2} \right) \right] + 3e_{min} \operatorname{tg} \left(\frac{\alpha}{2} \right) + \frac{e_{min}}{2 \operatorname{tg} \beta}$$

$$b = \frac{e_{min}}{2 \operatorname{tg} \beta}$$

$$3e_{min} \times \operatorname{tg} \left(\frac{\alpha}{2} \right) > 2 \text{ [mm]}$$

Figure 5 — Elbow

Table 4 — Elbows

Dimensions in millimetres

Nominal diameter D	Minimum laying lengths for nominal angle α					
	15°	22 1/2°	30°	45°	67 1/2°	87 1/2° to 88 1/2°
	z					
40	10	11	13	17	24	32
50	11	12	14	19	27	37
63	12	14	16	22	31	43
75	12	15	18	24	35	49
90	13	16	20	27	40	56
110	15	18	22	31	47	66
125	16	20	24	35	52	73
160	18	23	29	42	64	90