

Second edition  
2010-04-15

Corrected version  
2010-06-15

---

---

**Laboratory glassware — Volumetric  
instruments — Methods for testing of  
capacity and for use**

*Verrerie de laboratoire — Instruments volumétriques — Méthodes de  
vérification de la capacité et d'utilisation*

**iTeh STANDARD PREVIEW**  
**(standards.iteh.ai)**

[ISO 4787:2010](https://standards.iteh.ai/catalog/standards/sist/622ba6c2-c48c-4464-9497-6a50cdba5bc4/iso-4787-2010)

[https://standards.iteh.ai/catalog/standards/sist/622ba6c2-c48c-4464-9497-  
6a50cdba5bc4/iso-4787-2010](https://standards.iteh.ai/catalog/standards/sist/622ba6c2-c48c-4464-9497-6a50cdba5bc4/iso-4787-2010)



Reference number  
ISO 4787:2010(E)

© ISO 2010

**PDF disclaimer**

This PDF file may contain embedded typefaces. In accordance with Adobe's licensing policy, this file may be printed or viewed but shall not be edited unless the typefaces which are embedded are licensed to and installed on the computer performing the editing. In downloading this file, parties accept therein the responsibility of not infringing Adobe's licensing policy. The ISO Central Secretariat accepts no liability in this area.

Adobe is a trademark of Adobe Systems Incorporated.

Details of the software products used to create this PDF file can be found in the General Info relative to the file; the PDF-creation parameters were optimized for printing. Every care has been taken to ensure that the file is suitable for use by ISO member bodies. In the unlikely event that a problem relating to it is found, please inform the Central Secretariat at the address given below.

**iTeh STANDARD PREVIEW**  
**(standards.iteh.ai)**

ISO 4787:2010

<https://standards.iteh.ai/catalog/standards/sist/622ba6c2-c48c-4464-9497-6a50cdba5bc4/iso-4787-2010>



**COPYRIGHT PROTECTED DOCUMENT**

© ISO 2010

All rights reserved. Unless otherwise specified, no part of this publication may be reproduced or utilized in any form or by any means, electronic or mechanical, including photocopying and microfilm, without permission in writing from either ISO at the address below or ISO's member body in the country of the requester.

ISO copyright office  
Case postale 56 • CH-1211 Geneva 20  
Tel. + 41 22 749 01 11  
Fax + 41 22 749 09 47  
E-mail [copyright@iso.org](mailto:copyright@iso.org)  
Web [www.iso.org](http://www.iso.org)

Published in Switzerland

# Contents

Page

Foreword .....	iv
<b>1 Scope .....</b>	<b>1</b>
<b>2 Normative references .....</b>	<b>1</b>
<b>3 Terms and definitions .....</b>	<b>2</b>
<b>4 Summary of method .....</b>	<b>2</b>
<b>5 Volume and reference temperature .....</b>	<b>2</b>
5.1 Unit of volume.....	2
5.2 Reference temperature .....	2
<b>6 Apparatus and calibration liquid .....</b>	<b>2</b>
<b>7 Factors affecting the accuracy of volumetric instruments .....</b>	<b>3</b>
7.1 General .....	3
7.2 Temperature .....	3
7.3 Cleanliness of glass surface .....	3
7.4 Quality of used volumetric instruments.....	4
7.5 Delivery time and waiting time .....	4
<b>8 Setting the meniscus .....</b>	<b>4</b>
8.1 General .....	4
8.2 Meniscus of transparent liquids .....	4
8.3 Meniscus of opaque liquids .....	5
<b>9 Calibration procedure .....</b>	<b>5</b>
9.1 General .....	5
9.2 Test room .....	5
9.3 Filling and delivery .....	6
9.4 Weighing.....	7
9.5 Evaluation.....	7
<b>10 Use .....</b>	<b>7</b>
10.1 General .....	7
10.2 Volumetric flasks (see ISO 1042) .....	8
10.3 Measuring cylinders (see ISO 4788) .....	8
10.4 Burettes (see ISO 385).....	8
10.5 Pipettes.....	9
<b>Annex A (informative) Cleaning of volumetric glassware .....</b>	<b>10</b>
<b>Annex B (normative) Calculation of volume .....</b>	<b>11</b>
<b>Bibliography.....</b>	<b>21</b>

## Foreword

ISO (the International Organization for Standardization) is a worldwide federation of national standards bodies (ISO member bodies). The work of preparing International Standards is normally carried out through ISO technical committees. Each member body interested in a subject for which a technical committee has been established has the right to be represented on that committee. International organizations, governmental and non-governmental, in liaison with ISO, also take part in the work. ISO collaborates closely with the International Electrotechnical Commission (IEC) on all matters of electrotechnical standardization.

International Standards are drafted in accordance with the rules given in the ISO/IEC Directives, Part 2.

The main task of technical committees is to prepare International Standards. Draft International Standards adopted by the technical committees are circulated to the member bodies for voting. Publication as an International Standard requires approval by at least 75 % of the member bodies casting a vote.

Attention is drawn to the possibility that some of the elements of this document may be the subject of patent rights. ISO shall not be held responsible for identifying any or all such patent rights.

ISO 4787 was prepared by Technical Committee ISO/TC 48, *Laboratory equipment*, Subcommittee SC 6, *Laboratory and volumetric ware*.

This second edition cancels and replaces the first edition (ISO 4787:1984), which has been technically revised to incorporate the following changes:

- iTeh STANDARD PREVIEW**  
**(standards.iteh.ai)**
- a) the potassium dichromate cleaning method in Annex A has been deleted;
  - b) new tables for calculation of test results have been added to Annex B;
  - c) the description of the test (calibration) methods has been modified to be more precise;
  - d) test methods have been separated from recommendations for use.

This corrected version of ISO 4787:2010 incorporates the following corrections:

- Figure 1 on page 5 has been corrected to show the correct setting of the meniscus as described in the text;
- Figure 2 on page 5 has been improved to better illustrate what the user of the instrument really sees when setting the meniscus.

# Laboratory glassware — Volumetric instruments — Methods for testing of capacity and for use

## 1 Scope

This International Standard provides methods for the testing, calibration and use of volumetric instruments made from glass in order to obtain the best accuracy in use.

NOTE Testing is the process by which the conformity of the individual volumetric instrument with the appropriate standard is determined, culminating in the determination of its error of measurement at one or more points.

The International Standards for the individual volumetric instruments include clauses on the definition of capacity; these clauses describe the method of manipulation in sufficient detail to define the capacity without ambiguity. This International Standard contains supplementary information.

The procedures are applicable to volumetric instruments with nominal capacities in the range of 0,1 ml to 10 000 ml. These include: single-volume pipettes (see ISO 648) without subdivisions; graduated measuring pipettes and dilution pipettes, with partial or complete subdivisions (see ISO 835); burettes (see ISO 385); volumetric flasks (see ISO 1042); and graduated measuring cylinders (see ISO 4788). The procedures are not recommended for testing of volumetric instruments with capacities below 0,1 ml such as micro-glassware.

This International Standard does not deal specifically with pyknometers as specified in ISO 3507. However, the procedures specified below for the determination of volume of glassware can, for the most part, also be followed for the calibration of pyknometers.

## 2 Normative references

The following referenced documents are indispensable for the application of this document. For dated references, only the edition cited applies. For undated references, the latest edition of the referenced document (including any amendments) applies.

ISO 385, *Laboratory glassware — Burettes*

ISO 648, *Laboratory glassware — Single-volume pipettes*

ISO 835, *Laboratory glassware — Graduated pipettes*

ISO 1042, *Laboratory glassware — One-mark volumetric flasks*

ISO 3696, *Water for analytical laboratory use — Specification and test methods*

ISO 4788, *Laboratory glassware — Graduated measuring cylinders*

ISO/IEC Guide 99, *International vocabulary of metrology — Basic and general concepts and associated terms (VIM)*

### 3 Terms and definitions

For the purposes of this document, the terms and definitions given in ISO/IEC Guide 99 apply.

### 4 Summary of method

The general procedure is based upon a determination of volume of water, either contained in or delivered by the volumetric instrument. This volume of water is based upon knowledge of its mass under consideration of buoyancy and its tabulated density (gravimetric method).

### 5 Volume and reference temperature

#### 5.1 Unit of volume

The unit of volume shall be the millilitre (ml), which is equivalent to one cubic centimetre (cm<sup>3</sup>).

#### 5.2 Reference temperature

The standard reference temperature, i.e. the temperature at which the volumetric instrument is intended to contain or deliver its volume (capacity), shall be 20 °C.

When the volumetric instrument is required for use in a country which has adopted a standard reference temperature of 27 °C (the alternative recommended in ISO 384 for tropical use), this figure shall be substituted for 20 °C.

### 6 Apparatus and calibration liquid

**6.1 Balance**, with a resolution and standard deviation appropriate to the selected volume of the apparatus under test (see Table 1).

The resolution of the display, the standard deviation and the linearity of the balance will be a limiting factor in the accuracy of the measurements. The balance shall be calibrated with adequate accuracy (see 9.4).

**Table 1 — Recommended balance**

Selected volume under test <sup>a</sup>	Resolution	Standard deviation (repeatability)	Linearity
$V$	mg	mg	mg
$100 \mu\text{l} < V \leq 10 \text{ ml}$	0,1	0,2	0,2
$10 \text{ ml} < V < 1\ 000 \text{ ml}$	1	1	2
$1\ 000 \text{ ml} \leq V \leq 2\ 000 \text{ ml}$	10	10	20
$V > 2\ 000 \text{ ml}$	100	100	200

<sup>a</sup> For practical purposes, the nominal volume may be used to choose the balance.

**6.2 Thermometer**, to measure the temperature of the calibration liquid (water) with a measurement error of maximum 0,2 °C for liquid volumes < 1 000 ml and with a measurement error of maximum 0,1 °C for liquid volumes  $\geq$  1 000 ml.

**6.3 Hygrometer**, to measure the humidity in the test room with a measurement error of maximum 5 % within the humidity range of 35 % to 85 %.

**6.4 Barometer**, to measure the atmospheric pressure in the test room with a measurement error of maximum 1 kPa.

**6.5 Calibration liquid**, distilled or deionized water complying with ISO 3696, Grade 3 should be used for testing.

**6.6 Receiving vessel**, conical flask with ground joint, manufactured from glass, e.g. in accordance with ISO 4797. The nominal volume of the conical flask shall correspond to the volume of liquid to be measured.

## 7 Factors affecting the accuracy of volumetric instruments

### 7.1 General

The same sources of error are, naturally, inherent both in calibration and use. In the former, every attempt is made to reduce these errors to a minimum; in the latter, the care needed is dependent upon the degree of accuracy required. When the greatest possible accuracy is desired, the volumetric instrument should be used as closely as possible to the manner in which it has been calibrated.

### 7.2 Temperature

#### 7.2.1 Temperature of the volumetric instrument

**7.2.1.1** The capacity of the volumetric instruments varies with change of temperature. The particular temperature at which a volumetric instrument is intended to contain or deliver its nominal capacity is the "reference temperature" of the instrument (see 5.2).

**7.2.1.2** A volumetric instrument which was adjusted at 20 °C, but used at 27 °C, would show an extra error of only 0,007 % if it is made of borosilicate glass having a coefficient of cubical thermal expansion of  $9,9 \times 10^{-6} \text{ }^{\circ}\text{C}^{-1}$  and of 0,02 % if it is made of soda-lime glass having a coefficient of cubical thermal expansion of  $27 \times 10^{-6} \text{ }^{\circ}\text{C}^{-1}$ . These errors are smaller than the limits of error for most volumetric instruments. It follows, therefore, that the reference temperature is of minor importance in practical use. However, when performing calibrations, it is important to refer to the reference temperature.

#### 7.2.2 Temperature of calibration liquid

The temperature of the water used for the calibration shall be measured to  $\pm 0,1 \text{ }^{\circ}\text{C}$ . Corrections for differences in temperature from the reference temperature shall be applied in accordance with Annex B.

### 7.3 Cleanliness of glass surface

The volume contained in, or delivered by, a volumetric instrument depends on the cleanliness of the internal glass surface. Lack of cleanliness results in errors through a poorly shaped meniscus involving two defects:

- incomplete wetting of the glass surface, i.e. the liquid surface meets the glass at an arbitrary angle instead of forming a curve such that it meets the glass tangentially;
- a generally increased radius of curvature, due to contamination of the liquid surface reducing the surface tension.

The ascending or descending liquid meniscus shall not change shape (i.e. it shall not crinkle at its edges). To ascertain whether a piece of glass apparatus is satisfactorily clean, it shall be observed during filling and dispensing. Additionally, an experienced operator can recognize the shape of an uncontaminated meniscus, in relation to its diameter.

Lack of cleanliness causes additional errors with volumetric instruments used for delivery due to the film of liquid on the walls being irregularly distributed or incomplete, e.g. forming drops on the glass surface. Furthermore, chemical residues can introduce an error in the analytical result by contamination. Therefore, where volumetric instruments are fitted with ground stoppers, special attention shall be paid to cleaning the ground zone.

NOTE Small residues of acid, for example, could impair the concentration of the alkaline solution with which the volumetric instrument is filled.

A satisfactory method of cleaning is described in Annex A.

## 7.4 Quality of used volumetric instruments

The glass surface shall be free from obvious damage, the graduations and inscriptions shall be clearly readable and especially with instruments adjusted to deliver the jet shall be free from damage and allow an unrestricted outflow of liquid.

## 7.5 Delivery time and waiting time

For volumetric instruments used for delivery of a liquid, the volume delivered is always less than the volume contained, due to the film of liquid left on the inner walls of the volumetric instrument. The volume of this film depends on the time taken to deliver the liquid, and the volume delivered decreases with decreasing delivery time. For example, the delivered volume of a pipette or burette will decrease if the jet is broken (shorter delivery time) or will increase if the jet is not clean and the outflow of liquid is restricted.

In view of the above, delivery times and waiting times have been specified in the International Standards on volumetric instruments; these times shall be observed.

iTeh STANDARD PREVIEW  
(standards.iteh.ai)

## 8 Setting the meniscus

ISO 4787:2010

<https://standards.iteh.ai/catalog/standards/sist/622ba6c2-c48c-4464-9497-6a50cdba5bc4/iso-4787-2010>

### 8.1 General

Most volumetric instruments employ the principle of setting or reading a meniscus (the interface between air and the liquid) against a graduation line or ring mark. Wherever practicable, the meniscus should descend to the position of setting.

The tubing of the volumetric instrument shall be in a vertical position. The eye of the testing person shall be in the same horizontal plane as the meniscus or the graduation line (ring mark).

### 8.2 Meniscus of transparent liquids

The meniscus shall be set so that the plane of the upper edge of the graduation line is horizontally tangential to the lowest point of the meniscus, the line of sight being in the same plane (see Figure 1).

The lighting should be arranged so that the meniscus appears dark and distinct in outline. For this purpose, it should be viewed against a white background and shaded from undesirable illumination. This can be achieved, for example, by securing a strip of black or blue paper directly below the level of the graduation line or ring mark or by using a short section of thick black rubber tubing cut open at one side and of such size as to clasp the tube firmly. Parallax is avoided when the graduation lines are of sufficient length to be seen at the front and back of the volumetric instrument simultaneously.

On volumetric instruments which have graduation lines on the front only, parallax can be made negligible when making a setting on the top edge of the line by using the black shading strip, taking care that the top edge of this is in a horizontal plane. In this case, the eye shall be placed so that the front and back portions of the top edge appear to be coincident.



On volumetric instruments fitted with a Schellbach ribbon, the meniscus shall be set using the constriction produced by the interaction between the meniscus and the Schellbach ribbon. Setting is done when the tip of the constriction points to the graduation line (see Figure 2).

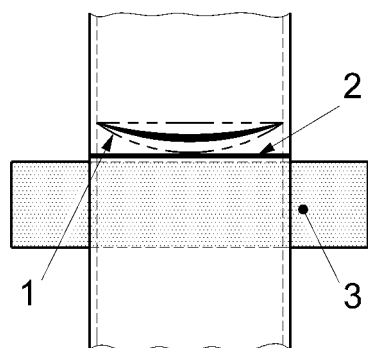

#### Key

- 1 meniscus of liquid
- 2 graduation line or ring mark
- 3 blue or black (dark) paper or black rubber tubing

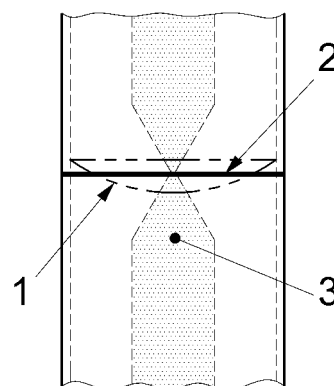

#### Key

- 1 meniscus
- 2 graduation line
- 3 Schellbach ribbon

Figure 1 — Setting of the meniscus with transparent liquids

Figure 2 — Meniscus with Schellbach ribbon

### 8.3 Meniscus of opaque liquids

When the volumetric instrument is used with opaque wetting liquids, the horizontal line of sight shall be taken through the upper edge of the meniscus, and, where necessary, an appropriate correction shall be applied.

In the case of a mercury meniscus, however, the highest point of the meniscus shall be set to the lower edge of the graduation line.

## 9 Calibration procedure

### 9.1 General

Volumetric instruments other than disposable pipettes shall be thoroughly cleaned shortly before calibration (see 7.3). Volumetric instruments adjusted to contain shall be dried after cleaning.

For volumetric instruments adjusted to deliver, it is important that receiving vessels manufactured from glass are used. Capillary effects influencing the delivery time and the delivered volume depend considerably on the material on which the liquid runs down. In addition, the electrostatic charges of glass are minimal; this is important for the weighing procedure.

### 9.2 Test room

The test shall be carried out in a draught-free room with stable environment. The test room shall have a relative humidity between 35 % and 85 % and shall provide a temperature locally constant to  $\pm 1$  °C and temporally constant to  $\pm 0,5$  °C between 15 °C and 30 °C. Prior to the test, the volumetric instrument to be tested and the test water shall have stood in the room for a sufficient time (1 h to 2 h) to reach equilibrium with the room conditions. Test water should be covered to avoid evaporation cooling. Temperatures (room and calibration liquid), atmospheric pressure and humidity should be recorded.

### 9.3 Filling and delivery

#### 9.3.1 Volumetric flasks and measuring cylinders

Volumetric flasks in accordance with ISO 1042 and measuring cylinders in accordance with ISO 4788 shall be dried after cleaning. They shall be filled by means of a plastic tube with tip to a distance of a few millimetres above the ring mark or the graduation line to be tested, so that the walls of the volumetric instrument considerably above the ring mark are not wetted. The final setting of the meniscus to the ring mark or graduation line shall be made by withdrawing the surplus water by means of a plastic tube drawn out to a jet. The movement of the meniscus when setting shall be downwards. If a little refilling is necessary or if the reading is delayed to the adjustment of the meniscus, careful swaying is necessary to refresh the meniscus shape.

#### 9.3.2 Pipettes adjusted to deliver

Pipettes adjusted to deliver according to the specifications in ISO 648 and ISO 835 shall be clamped in a vertical position and filled through the jet to a few millimetres above the graduation line to be tested; any liquid remaining on the outside of the jet shall be removed. The final setting of the meniscus shall then be made by running out the surplus water through the jet. Any drop of liquid adhering to the jet shall be removed, for example by bringing a ground glass surface into contact with the tip of the jet at an angle of about 30°. Draw this ground glass surface downwards through a distance of about 10 mm to remove residual water. Delivery into the tared receiving vessel shall then be made with the flow unrestricted while the tip of the jet is in contact with the inner ground surface of the receiving vessel, finally drawing it over a distance of about 10 mm, with the receiving vessel held inclined at an angle of about 30°.

Other precautions which are necessary to obtain the correct delivered volume vary with different types of instruments and are described in the clause defining capacity in the appropriate International Standards.

Determine the delivery time while the tip of the jet is in contact with the inner surface of the receiving vessel, above the level of any collected liquid, but without movement of one against the other throughout the delivery period. The delivery time thus determined should be within the limits specified for the particular pipette. For further details, see ISO 648 and ISO 835.

A waiting time, if specified, shall be observed before making the final setting of the meniscus for delivery of a given volume. If the setting after delivery is done at a lower graduation line, the liquid flow shall be nearly stopped a few millimetres above the graduation line. After observation of the waiting time, the final setting shall be completed quickly.

#### 9.3.3 Pipettes adjusted to contain

See 10.5.2.

#### 9.3.4 Burettes adjusted to deliver

Burettes adjusted to deliver according to ISO 385 shall be clamped in a vertical position and filled through the jet to a few millimetres above the graduation line to be tested. The stopcock and jet shall be freed from air bubbles. Any liquid remaining on the outside of the jet shall be removed. The final setting of the meniscus shall then be made by running out the surplus water through the jet. Any drop of liquid adhering to the jet shall be removed by bringing a ground glass surface into contact with the tip of the jet at an angle of about 30°. Draw this ground glass surface downwards through a distance of about 10 mm.

Delivery into the tared receiving vessel shall then be made with the flow unrestricted until the meniscus has come to a few millimetres above the graduation line to be tested, while the stopcock is fully open and the jet is not in contact with the receiving vessel. After the final setting of the meniscus, any drop of liquid adhering to the jet is removed by bringing an inclined glass surface into contact with the tip of the jet at an angle of about 30°, finally drawing it over a distance of about 10 mm.

Other precautions which are necessary to obtain the correct delivered volume vary with different types of burettes and are described in the appropriate International Standards in the clause defining capacity.

Determine the delivery time by the unrestricted outflow of the liquid from the zero mark to the lowest graduation mark with the stopcock fully open and the jet not being in contact with the surface of the receiving vessel. The delivery time thus determined should be within the limits specified for the particular burette. For further details, see ISO 385.

A waiting time, if specified, shall be observed before making the final setting of the meniscus for delivery of a given volume. If the setting after delivery is done at a lower graduation line, the liquid flow shall be nearly stopped a few millimetres above the graduation line. After observation of the waiting time, the final setting shall be completed quickly.

## 9.4 Weighing

The volumetric instrument or the receiving vessel (see 6.6) shall be tared and weighed using a balance in accordance with 6.1 and the temperature of the water shall be measured to  $\pm 0,1$  °C.

Alternatively, two weighings can be performed, namely  $I_L$ , referring to the loaded vessel, and  $I_E$ , referring to the empty vessel. Usually,  $I_E$  and  $I_L$  are observed under the same conditions, hence a precise zero adjustment of the balance is not necessary. Both of the required weighings shall be carried out in as short a time interval as convenient to ensure that they have been made at the same temperature. This temperature and the barometric pressure shall be recorded for use in the subsequent calculations.

The manufacturer's instructions shall be followed in making the requisite measurements. Weighings shall be made with care and made expeditiously to minimize evaporation losses which would constitute a source of error.

## 9.5 Evaluation

The balance reading after tare or the difference of the results of the first and second weighing is the apparent mass of the water contained in, or delivered by, the volumetric instrument tested.

NOTE The apparent mass, thus obtained, is the mass uncorrected for air buoyancy.

In order to obtain the volume contained in, or delivered by, the volumetric instrument under test at the reference temperature from the apparent mass of water, the following factors shall be taken into account:

- a) the density of water at the temperature of test;
- b) the thermal expansion of the glass between the temperature of test and the reference temperature;
- c) the effect of air buoyancy on the water and on the weights used.

Instructions for calculating the volume of the instrument and tables, in which these factors have been taken into account for a reference temperature of 20 °C, are given in Annex B.

## 10 Use

### 10.1 General

Where the greatest attainable accuracy is required, volumetric instruments shall be manipulated in a manner as similar as possible to that employed during calibration as described in Clause 9. For further details, see the relevant clause "Definition of capacity" or "Basis of adjustment" in the appropriate International Standards.

Always clean volumetric instruments before use (see 7.3) and check the jet for possible damage and unrestricted outflow of liquid with volumetric instruments adjusted to deliver.