Aerospace — Bolts, large bihexagonal head, normal shank, short or medium length MJ threads, metallic material, coated or uncoated, strength classes 1 250 MPa to 1 800 MPa — Dimensions

Aéronautique et espace — Vis à tête bihexagonale large, avec tige normale et filetages MJ courts ou de longueur moyenne, en matériau métallique, revêtues ou non revêtues, des classes de résistance 1 250 MPa à 1 800 MPa — Dimensions

[ISO 3186:2008](#)

<https://standards.iteh.ai/catalog/standards/sist/1cefb30d-3293-43e0-9079-0d477e8876a3/iso-3186-2008>



PDF disclaimer

This PDF file may contain embedded typefaces. In accordance with Adobe's licensing policy, this file may be printed or viewed but shall not be edited unless the typefaces which are embedded are licensed to and installed on the computer performing the editing. In downloading this file, parties accept therein the responsibility of not infringing Adobe's licensing policy. The ISO Central Secretariat accepts no liability in this area.

Adobe is a trademark of Adobe Systems Incorporated.

Details of the software products used to create this PDF file can be found in the General Info relative to the file; the PDF-creation parameters were optimized for printing. Every care has been taken to ensure that the file is suitable for use by ISO member bodies. In the unlikely event that a problem relating to it is found, please inform the Central Secretariat at the address given below.

iTeh STANDARD PREVIEW
(standards.iteh.ai)

ISO 3186:2008

<https://standards.iteh.ai/catalog/standards/sist/1cefb30d-3293-43e0-9079-0d477e8876a3/iso-3186-2008>



COPYRIGHT PROTECTED DOCUMENT

© ISO 2008

All rights reserved. Unless otherwise specified, no part of this publication may be reproduced or utilized in any form or by any means, electronic or mechanical, including photocopying and microfilm, without permission in writing from either ISO at the address below or ISO's member body in the country of the requester.

ISO copyright office
Case postale 56 • CH-1211 Geneva 20
Tel. + 41 22 749 01 11
Fax + 41 22 749 09 47
E-mail copyright@iso.org
Web www.iso.org

Published in Switzerland

Foreword

ISO (the International Organization for Standardization) is a worldwide federation of national standards bodies (ISO member bodies). The work of preparing International Standards is normally carried out through ISO technical committees. Each member body interested in a subject for which a technical committee has been established has the right to be represented on that committee. International organizations, governmental and non-governmental, in liaison with ISO, also take part in the work. ISO collaborates closely with the International Electrotechnical Commission (IEC) on all matters of electrotechnical standardization.

International Standards are drafted in accordance with the rules given in the ISO/IEC Directives, Part 2.

The main task of technical committees is to prepare International Standards. Draft International Standards adopted by the technical committees are circulated to the member bodies for voting. Publication as an International Standard requires approval by at least 75 % of the member bodies casting a vote.

Attention is drawn to the possibility that some of the elements of this document may be the subject of patent rights. ISO shall not be held responsible for identifying any or all such patent rights.

ISO 3186 was prepared by Technical Committee ISO/TC 20, *Aircraft and space vehicles*, Subcommittee SC 4, *Aerospace fastener systems*.

This second edition cancels and replaces the first edition (ISO 3186:1994), which has been technically revised.

iTeh STANDARD PREVIEW
(standards.iteh.ai)

ISO 3186:2008
<https://standards.iteh.ai/catalog/standards/sist/1cefb30d-3293-43e0-9079-0d477e8876a3/iso-3186-2008>

iTeh STANDARD PREVIEW
(standards.iteh.ai)

ISO 3186:2008

<https://standards.iteh.ai/catalog/standards/sist/1cefb30d-3293-43e0-9079-0d477e8876a3/iso-3186-2008>

Aerospace — Bolts, large bihexagonal head, normal shank, short or medium length MJ threads, metallic material, coated or uncoated, strength classes 1 250 MPa to 1 800 MPa — Dimensions

1 Scope

This International Standard specifies the dimensions of large bihexagonal head bolts, with close or large tolerance normal shank and short or medium length MJ threads, in metallic material, coated or uncoated, with strength classes 1 250 MPa to 1 800 MPa.

This International Standard is applicable to the compilation of aerospace product standards.

2 Normative references

The following referenced documents are indispensable for the application of this document. For dated references, only the edition cited applies. For undated references, the latest edition of the referenced document (including any amendments) applies.

ISO 286-2, *ISO system of limits and fits — Part 2: Tables of standard tolerance grades and limit deviations for holes and shafts*

ISO 3353-1, *Aerospace — Lead and runout threads — Part 1: Rolled external threads*

ISO 4095, *Aerospace — Bihexagonal drives — Wrenching configuration — Metric series*

ISO 5855-2, *Aerospace — MJ threads — Part 2: Limit dimensions for bolts and nuts*

ISO 7913, *Aerospace — Bolts and screws, metric — Tolerances of form and position*

3 Configuration and dimensions

See Figure 1 and Table 1.

Dimensions and tolerances are expressed in millimetres. They are applicable after any coating (tolerance on shank diameter before coating is also specified for heat cured matrix coatings), but before the application of any lubricant.

Details of form not stated are left to the manufacturer's discretion.

Tolerances of form and position shall be as specified in ISO 7913 if not otherwise stated on product standard.

Dimensions in millimetres

Break sharp edges 0,1 to 0,4

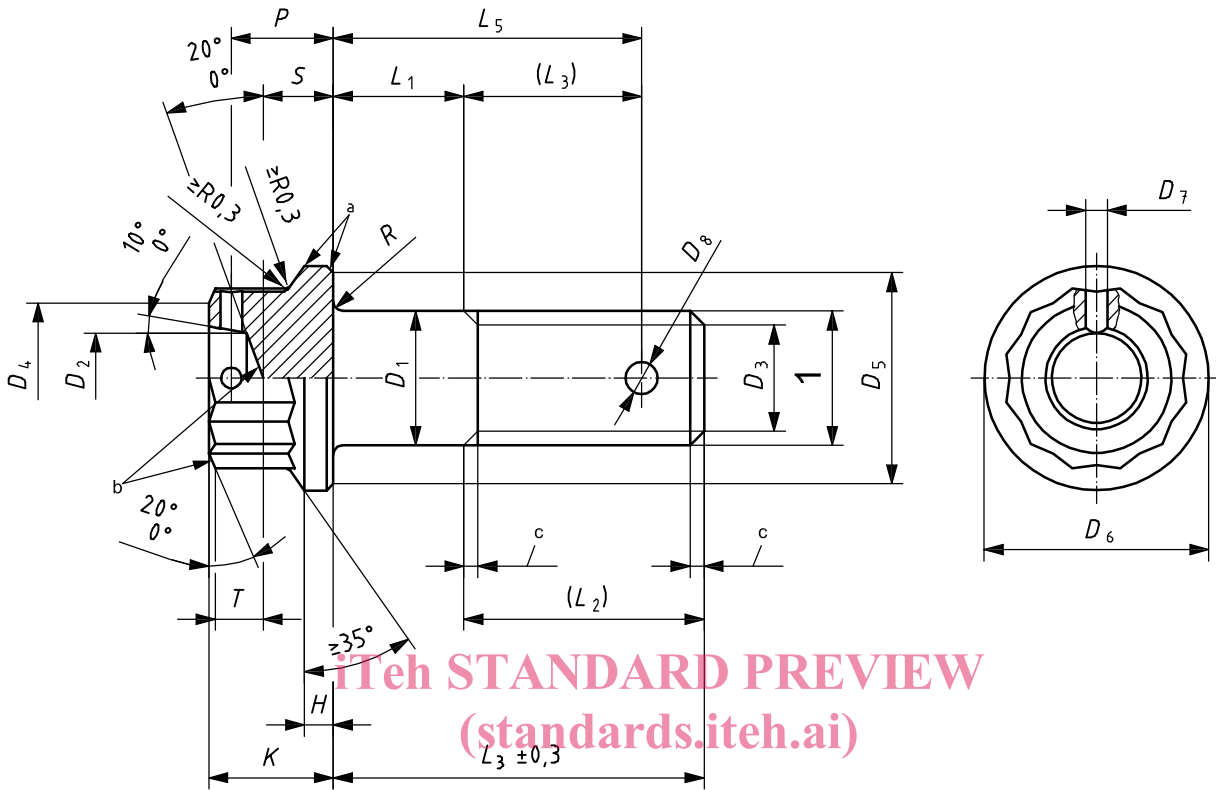

STANDARD PREVIEW
(standards.itech.ai)

ISO 3186:2008

<https://standards.itech.ai/catalog/standards/sist/1cefb30d-3293-43e0-9079-0d477e8876a3/iso-3186-2008>

Key

- 1 thread
- a Rounded or chamfered in this area.
- b Shape optional.
- c In accordance with ISO 3353-1.

Figure 1

iTeh STANDARD PREVIEW
(standards.iteh.ai)

[Blank page]

[ISO 3186:2008](#)

<https://standards.iteh.ai/catalog/standards/sist/1cefb30d-3293-43e0-9079-0d477e8876a3/iso-3186-2008>

Table 1

Diameter code	Thread ^a	nom.	<i>D</i> ₁					<i>D</i> ₂	<i>D</i> ₃	<i>D</i> ₄	<i>D</i> ₅	<i>D</i> ₆	<i>D</i> ₇ Four holes equidistant optional H13 ^c	<i>D</i> ₈ One hole, optional H13 ^c
			Coated bolts			Uncoated bolts								
			Tol.			Tol.								
			before coating ^b	close	large	close	large							
050	MJ5 × 0,8-4h6h	5	-0,030 -0,045	-0,010 -0,035								1	1,5	
060	MJ6 × 1-4h6h	6					3,2	4,2	7,8	11	11,8	1,4	1,9	
070	MJ7 × 1-4h6h	7					3,9	5,2	8,8	12,5	13,3			
080	MJ8 × 1-4h6h	8	-0,033 -0,048	-0,013 -0,038			4,5	6,2	9,8	14	14,8			
100	MJ10 × 1,25-4h6h	10					6,1	7,9	11,8	17,3	18,3	1,6	2,4	
120	MJ12 × 1,25-4h6h	12					7,7	9,8	13,7	20,9	22			
140	MJ14 × 1,5-4h6h	14	-0,036 -0,051	-0,016 -0,041	h12 ^c	f7 ^c	h12 ^c	10,3	11,5	16,7	23,9		25	3
160	MJ16 × 1,5-4h6h	16					11,9	13,5	18,6	27,4	28,5			
180	MJ18 × 1,5-4h6h	18					14,5	15,5	21,6	30,4	31,5			
200	MJ20 × 1,5-4h6h	20					16	17,5	23,6	33,4	34,5	3,8		
220	MJ22 × 1,5-4h6h	22	-0,040 -0,055	-0,020 -0,045			18,6	19,5	26,6	36,4	37,5			
240	MJ24 × 2-4h6h	24					21,2	20,9	29,6	39,4	40,5			

iTech STANDARD PREVIEW
(standards.itech.ai)
ISO 3186:2008
<https://standards.itech.ai/catalog/standards/sist/10c1f30d-53295-43e0-9079-0d477e8876a3/iso-3186-2008>

Table 1 (continued)

<i>H</i> min.	<i>K</i> h15 ^c	$L_1 \pm 0,2^d$	L_2			L_3		<i>P</i>	<i>R</i> 0 -2	<i>S</i> +0,4 0	<i>T</i> min.	Wrenching dash number ^e
			Thread			Thread						
			short	medium		short	medium					
				Strength class MPa								
1 250	> 1 250											
1,5	7,4	3 to 50	9	12	12,5	6	7,5	5,3	0,8	3,3	2,8	07
1,7	8,4	3 to 60	10	14	15	7	8,5	6,1	1	3,8	3,5	08
1,9	9,2	4 to 70	11	15	16		9,5	6,7		4,2	3,8	09
2,1	9,8	4 to 80	11,5	16,5	17	7,5	10,5	7,2		4,6	3,9	10
2,5	11,6	5 to 100	14,5	20,5	21	9	13	8,5	1,2	5,5	4,2	12
2,9	12,9	6 to 120	16	22,5	23,5	10	14,5	9,6	1,4	6,4	4,5	14
3,3	14,3	7 to 140	19	26	27,5	12	17	10,8		7,1	5,1	17
3,7	15,8	8 to 160	20,5	28,5	30	12,5	18,5	12,4	1,8	8,4	5,3	19
4,1	17,1	9 to 180	22,5	31	33	14,5	21	13,9		9,4	6,1	22
4,5	18,6	10 to 200	24,5	33,5	35,5	15	22,5	15,3		10,5	6,6	24
4,9	19,9	11 to 220	26	36	38	16	24	16,8	1,8	11,6	7,4	27
5,3	21,9	12 to 240	29,5	41	43,5	17,5	26,5	18,3		12,7	8,2	30

^a In conformity with ISO 5855-2, except for the maximum thread major diameter, d_{max} , of bolts with a close tolerance on D_1 , which shall be equal to $(D_{1,min} - 0,025)$.

^b Heat cured organic matrix coatings for close tolerance normal shanks.

^c See ISO 286-2.

^d Increments: 1 for $L_1 \leq 30$;
2 for $30 < L_1 \leq 100$;
4 for $L_1 > 100$.

If greater lengths are required, they shall be chosen using these increments.

^e In conformity with ISO 4095 over T min.