



Designation: E430 – 05

Standard Test Methods for Measurement of Gloss of High-Gloss Surfaces by Abridged Goniophotometry¹

This standard is issued under the fixed designation E430; the number immediately following the designation indicates the year of original adoption or, in the case of revision, the year of last revision. A number in parentheses indicates the year of last reapproval. A superscript epsilon (ϵ) indicates an editorial change since the last revision or reapproval.

1. Scope

1.1 These test methods cover the measurement of the reflection characteristics responsible for the glossy appearance of high-gloss surfaces. Two test methods, A and B, are provided for evaluating such surface characteristics at specular angles of 30° and 20°, respectively. These test methods are not suitable for diffuse finish surfaces nor do they measure color, another appearance attribute.

1.2 As originally developed by Tingle and others (see Refs 1 and 2),² the test methods were applied only to bright metals. Recently they have been applied to high-gloss automotive finishes and other nonmetallic surfaces.

2. Referenced Documents

2.1 *ASTM Standards*:³

D523 Test Method for Specular Gloss

D2457 Test Method for Specular Gloss of Plastic Films and Solid Plastics

E171 Specification for Atmospheres for Conditioning and Testing Flexible Barrier Materials

E179 Guide for Selection of Geometric Conditions for Measurement of Reflection and Transmission Properties of Materials

E284 Terminology of Appearance

E308 Practice for Computing the Colors of Objects by Using the CIE System

E1347 Test Method for Color and Color-Difference Measurement by Tristimulus Colorimetry

3. Terminology

3.1 *Definitions*—Appearance terms in this test method are in accordance with Terminology E284.

¹ These test methods are under the jurisdiction of ASTM Committee E12 on Color and Appearance and are the direct responsibility of Subcommittee E12.03 on Geometry.

Current edition approved June 1, 2005. Published July 2005. Originally approved in 1971. Last previous edition approved in 2003 as E430 – 97 (2003). DOI: 10.1520/E0430-05.

² The boldface numbers in parentheses refer to the list of references at the end of this method.

³ For referenced ASTM standards, visit the ASTM website, www.astm.org, or contact ASTM Customer Service at service@astm.org. For *Annual Book of ASTM Standards* volume information, refer to the standard's Document Summary page on the ASTM website.

3.2 Terms that are defined in Terminology E284, but have a specific definition in this method are:

3.2.1 *reflectance, p, n*—ratio of the reflected radiant or luminous flux to the incident flux in the given conditions. (E284)

3.2.1.1 *Discussion*—The term *reflectance* is often used in a general sense or as an abbreviation for *reflectance factor*. Such usage is not assumed in this method. The definition may require that the term be modified by adjectives denoting the spectral and geometric conditions of measurement.

3.3 *Definitions of Terms Specific to This Standard*:

3.3.1 *reflection haze, H, n*—for a specified specular angle, ratio of flux reflected at a specified angle (or angles) from the specular direction to the flux similarly reflected at the specular angle by a specified gloss standard.

3.3.1.1 *Discussion*—Modifiers may be used to specify the angles at which the haze is measured (for example, 2° or –5°); whether $-H$ or a logarithmic form is to be stated; or whether H is to be compensated for the luminance of the specimen by multiplication by $Y_{specimen}/Y_n$, where n denotes the reference white; or any combination of these.

3.3.2 *metallic brightness, n*—freedom of a metal surface from diffuse haze or texture.

3.3.3 *'with-machine' direction, n*—the axis of a specimen that is parallel to the direction of mill rolling or extrusion, or other surface-finish texture.

3.3.4 *'across-machine' direction, n*—the perpendicular to 'with-machine' direction.

4. Summary of Test Method

4.1 Several geometrically different measures of light reflected by a surface are proposed for use in describing its gloss appearance. In Test Method A, gloss reflectance factor is measured at 30° to the specimen normal using narrow illuminator and receiver aperture angles (0.5° wide maximum). Distinctness-of-image gloss is measured at 29.7 or 30.3° or both. Narrow-angle (2°) reflection haze is measured at 28 or 32° or both, and wide-angle (5°) reflection haze at 25 or 35° or both. The ratio of reflectance factors for 28 or 32° or both, perpendicular and parallel to the machine direction of the specimen, is computed as a measure of directionality. In Method B, specular gloss is measured at 20° in accordance with Test Method D523, and narrow-angle reflection haze is

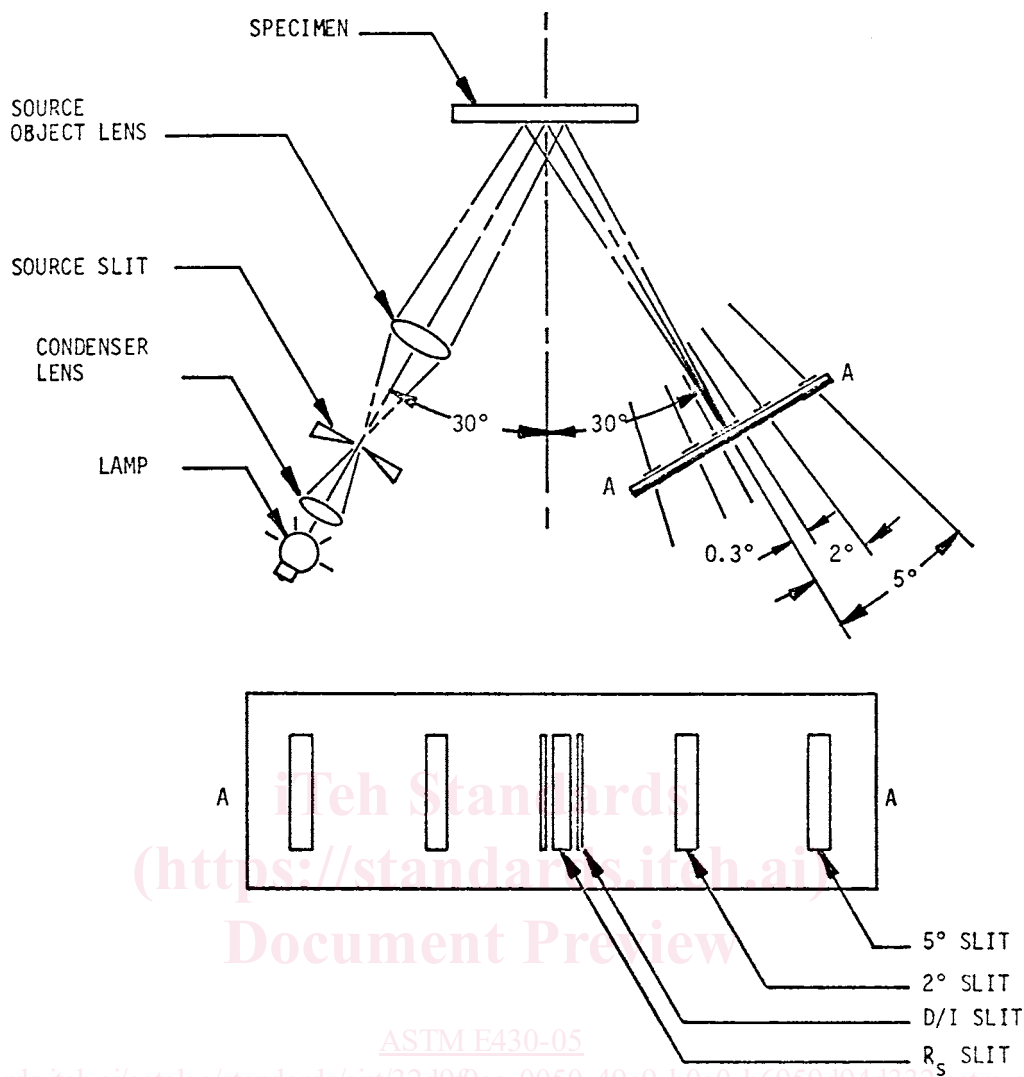

FIG. 1 Optical Diagram of the Apparatus for Method A

measured at 18.1 and 21.9°. For additional information on the selection of geometric conditions, see Guide E179.

5. Significance and Use

5.1 The gloss of metallic finishes is important commercially on metals for automotive, architectural, and other uses where these metals undergo special finishing processes to produce the appearances desired. It is important for the end-products, which use such finished metals that parts placed together have the same glossy appearance.

5.2 It is also important that automotive finishes and other high-gloss nonmetallic surfaces possess the desired finished appearance. The present method identifies by measurements important aspects of finishes. Those having identical sets of numbers normally have the same gloss characteristics. It usually requires more than one measurement to identify properly the glossy appearance of any finish (see Refs 3 and 4).

6. Apparatus

6.1 The apparatus shall be an abridged goniophotometer (see Fig. 1 and Fig. 2). The abridged goniophotometer may

have a fixed angle of incidence (for Test Method A, 30°; for Test Method B, 20°) and specific fixed directions of view at which the flux from the specimen is measured (see Table 1 and Table 2).⁴

6.1.1 *Geometric Conditions for Test Method A*—The direction of incidence shall be 30°. The directions of view shall be opposite the direction of incidence at 30° for specular reflectance, 29.7 or 30.3° for distinctness of image comparisons, 28 or 32° for narrow-angle haze comparisons, and 25 or 35° for wide-angle haze comparisons. The angular dimensions of the mirror reflected image of the source slit in the plane of measurement and the angular dimensions of the receiver windows in this plane of measurement shall be as shown in Table 1.

⁴ The sole source of supply of the apparatus known to the committee at this time for Method A is Hunter Associates Laboratory, Reston, VA, and for Method B is BVK-Gardner USA, Columbia, MD. If you are aware of alternative suppliers, please provide this information to ASTM International Headquarters. Your comments will receive careful consideration at a meeting of the responsible technical committee,¹ which you may attend.

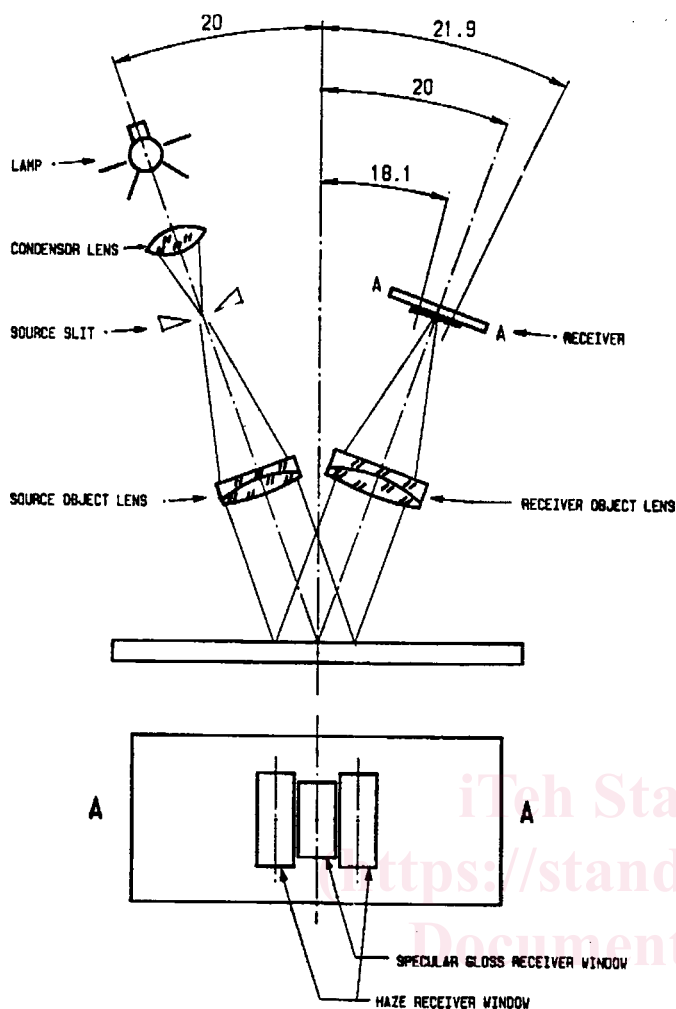

FIG. 2 Optical Diagram of the Apparatus for Method B

6.1.2 *Geometric Conditions for Test Method B*—The direction of incidence shall be $20 \pm 0.1^\circ$. The directions of view shall be opposite the direction of incidence, at 20° for specular gloss measurement and at 18.1 and 21.9° for narrow-angle reflection haze measurement. The angular dimensions of the specularly reflected image of the source slit in the plane of measurement and the angular dimensions of the receiver windows in this plane of measurement shall be as shown in Table 2.

6.1.3 *Spectral Conditions*—The measurement shall be made with visible light to give results in accordance with the CIE spectral luminous efficiency function $V(\lambda)$, which is identical with \bar{y} in the CIE 1931 standard observer and CIE standard illuminant C (see Practice E308 and Test Method E1347). If another illuminant such as A, is used, this shall be specified in the report.

6.1.4 *Polarization*—The incident flux shall be unpolarized and the receiver shall be insensitive to the state of polarization of the reflected luminous flux.

6.1.5 *Clamp*—For Test Method A, a rotatable clamp of the type shown in Fig. 3 may be used for flattening and positioning the specimen during measurement.

7. Standards

7.1 Three calibrated standards of good planarity shall be available in either a set of metals or a set of nonmetals, depending upon which type of surface is measured.

7.2 High-Gloss Standards:

7.2.1 *High-Gloss Standard for Metals* shall be of aluminum, evaporated onto glass and covered with a protective coating of silicon monoxide, and calibrated for specular gloss and distinctness-of-image gloss.

7.2.2 *High-Gloss Standard for Nonmetals* shall be of highly polished black glass with a refractive index of approximately $n_D = 1.527$, calibrated for specular gloss and reflection haze, and assigned a scale value of $G_s = 89.4$ for a specular angle of 30° (Test Method A) or $G_s = 89.2$ for a specular angle of 20° (Test Method B).

NOTE 1—To determine the scale value, calculate the first-surface (Fresnel) reflectance (see Test Method D2457, Instrumental Components in Apparatus section) for $n_D = 1.567$ and the specular angle of interest; for 30° it is 5.0436 % and for 20° it is 4.9078 %. Assign this a scale value of 100 (see Test Method D523, Primary Standards in Reference Standards section). Repeat the calculation for $n_p = 1.527$ and the same specular angle; the result for 30° is 4.5069 % and for 20° , 4.3769 %. The new scale value for 30° is $100 \times (4.5069/5.0436) = 89.4$, and for 20° , $100 \times (4.3769/4.9078) = 89.2$. (The latter value is also given in Test Method D523.)

7.3 Intermediate Standards:

7.3.1 *Intermediate Standard for Metals* shall be of either chromium evaporated onto glass and covered with a protective coating of silicon monoxide, or of bright sheet aluminum with protective coating and calibrated for specular gloss and distinctness-of-image gloss.

7.3.2 *Intermediate Standard for Nonmetals* shall be of a ceramic material, such as porcelain enamel on steel, and calibrated for specular gloss and distinctness-of-image gloss.

7.4 *Diffuse Standards* shall have a reflectance factor substantially constant over the angular range of the instrument.

7.5 *Care of Standards*—It is essential that the standards be kept clean and free of scratches as well as from contact with contaminating materials. The cleaning method specified by the instrument manufacturer shall be followed and the standards should be checked at regular intervals against reference standards held in reserve.

8. Specimens

8.1 Specimens shall be obtained from test samples by selecting areas that are plane and representative of each sample being tested. Every specimen must be at least $2\frac{3}{4}$ in. (70 mm) in the smallest dimension. Specimens may be larger so long as it is possible to insert them into the instrument and flatten them properly for measurement.

9. Preparation and Standardization of Apparatus

9.1 The instrument must be used in a clean dry area free of drafts. Standard laboratory conditions are recommended (see Referenced Documents section in Specification E171). Voltage regulation to ± 0.01 % must be incorporated in the instrument, or supplied separately. Follow manufacturer's recommendations for instrument warm-up.