

---

---

**Road vehicles — Elastomeric seals for  
hydraulic disc brake cylinders using a  
non-petroleum base hydraulic brake fluid  
(Service temperature 150 °C max.)**

*Véhicules routiers — Joints en caoutchouc pour cylindres de freins  
hydrauliques à disque utilisant un liquide de frein à base non pétrolière  
(Température maximale d'utilisation 150 °C)*

iTeh STANDARD PREVIEW  
(standards.iteh.ai)

[ISO 4930:2006](https://standards.iteh.ai/catalog/standards/sist/79573e5f-1fdc-41be-badc-5f567217986d/iso-4930-2006)

<https://standards.iteh.ai/catalog/standards/sist/79573e5f-1fdc-41be-badc-5f567217986d/iso-4930-2006>



**PDF disclaimer**

This PDF file may contain embedded typefaces. In accordance with Adobe's licensing policy, this file may be printed or viewed but shall not be edited unless the typefaces which are embedded are licensed to and installed on the computer performing the editing. In downloading this file, parties accept therein the responsibility of not infringing Adobe's licensing policy. The ISO Central Secretariat accepts no liability in this area.

Adobe is a trademark of Adobe Systems Incorporated.

Details of the software products used to create this PDF file can be found in the General Info relative to the file; the PDF-creation parameters were optimized for printing. Every care has been taken to ensure that the file is suitable for use by ISO member bodies. In the unlikely event that a problem relating to it is found, please inform the Central Secretariat at the address given below.

**iTeh STANDARD PREVIEW**  
**(standards.iteh.ai)**

[ISO 4930:2006](https://standards.iteh.ai/catalog/standards/sist/79573e5f-1fdc-41be-badc-5f567217986d/iso-4930-2006)

<https://standards.iteh.ai/catalog/standards/sist/79573e5f-1fdc-41be-badc-5f567217986d/iso-4930-2006>

© ISO 2006

All rights reserved. Unless otherwise specified, no part of this publication may be reproduced or utilized in any form or by any means, electronic or mechanical, including photocopying and microfilm, without permission in writing from either ISO at the address below or ISO's member body in the country of the requester.

ISO copyright office  
Case postale 56 • CH-1211 Geneva 20  
Tel. + 41 22 749 01 11  
Fax + 41 22 749 09 47  
E-mail [copyright@iso.org](mailto:copyright@iso.org)  
Web [www.iso.org](http://www.iso.org)

Published in Switzerland

## Contents

Page

Foreword.....	iv
<b>1 Scope .....</b>	<b>1</b>
<b>2 Normative references .....</b>	<b>1</b>
<b>3 Product requirements.....</b>	<b>1</b>
<b>4 Brake test fluid .....</b>	<b>1</b>
<b>5 Apparatus .....</b>	<b>2</b>
<b>5.1 Apparatus for test of resistance to fluid at elevated temperature, physical stability and precipitation characteristics .....</b>	<b>2</b>
<b>5.2 Apparatus for high-temperature stroking test (see Figure 1) .....</b>	<b>2</b>
<b>5.3 Apparatus for low-temperature leakage test (see Figure 2).....</b>	<b>3</b>
<b>6 Test requirements.....</b>	<b>3</b>
<b>7 Preparation of test specimens .....</b>	<b>4</b>
<b>8 Resistance to fluid at elevated temperature .....</b>	<b>4</b>
<b>8.1 Test specimens .....</b>	<b>4</b>
<b>8.2 Test procedure .....</b>	<b>5</b>
<b>9 Resistance to fluid at elevated temperature – Precipitation characteristics.....</b>	<b>5</b>
<b>9.1 Test specimens .....</b>	<b>5</b>
<b>9.2 Test procedure .....</b>	<b>5</b>
<b>10 Resistance to elevated temperature in dry air.....</b>	<b>6</b>
<b>10.1 Test specimens .....</b>	<b>6</b>
<b>10.2 Test procedure .....</b>	<b>6</b>
<b>11 Ambient-temperature stroking test.....</b>	<b>6</b>
<b>11.1 Test specimens .....</b>	<b>6</b>
<b>11.2 Test procedure .....</b>	<b>6</b>
<b>12 High-temperature stroking test .....</b>	<b>7</b>
<b>12.1 Test specimens .....</b>	<b>7</b>
<b>12.2 Test procedure .....</b>	<b>7</b>
<b>13 Low-temperature leakage test .....</b>	<b>8</b>
<b>13.1 Test specimens .....</b>	<b>8</b>
<b>13.2 Test procedure .....</b>	<b>8</b>
<b>13.3 Bent test procedure .....</b>	<b>9</b>
<b>14 Cycling humidity storage corrosion test.....</b>	<b>9</b>
<b>14.1 Test specimens .....</b>	<b>9</b>
<b>14.2 Test procedure .....</b>	<b>9</b>

## Foreword

ISO (the International Organization for Standardization) is a worldwide federation of national standards bodies (ISO member bodies). The work of preparing International Standards is normally carried out through ISO technical committees. Each member body interested in a subject for which a technical committee has been established has the right to be represented on that committee. International organizations, governmental and non-governmental, in liaison with ISO, also take part in the work. ISO collaborates closely with the International Electrotechnical Commission (IEC) on all matters of electrotechnical standardization.

International Standards are drafted in accordance with the rules given in the ISO/IEC Directives, Part 2.

The main task of technical committees is to prepare International Standards. Draft International Standards adopted by the technical committees are circulated to the member bodies for voting. Publication as an International Standard requires approval by at least 75 % of the member bodies casting a vote.

Attention is drawn to the possibility that some of the elements of this document may be the subject of patent rights. ISO shall not be held responsible for identifying any or all such patent rights.

ISO 4930 was prepared by Technical Committee ISO/TC 22, *Road vehicles*, Subcommittee SC 2, *Braking systems and equipment*.

This second edition cancels and replaces the first edition (ISO 4930:1978), which has been technically revised.

**iTeh STANDARD PREVIEW**  
**(standards.iteh.ai)**

[ISO 4930:2006](https://standards.iteh.ai/catalog/standards/sist/79573e5f-1fdc-41be-badc-5f567217986d/iso-4930-2006)

<https://standards.iteh.ai/catalog/standards/sist/79573e5f-1fdc-41be-badc-5f567217986d/iso-4930-2006>

# Road vehicles — Elastomeric seals for hydraulic disc brake cylinders using a non-petroleum base hydraulic brake fluid (Service temperature 150 °C max.)

## 1 Scope

This International Standard specifies the performance test methods and requirements for elastomeric seals used in road vehicle disc brake cylinders.

It is applicable to solid section type seals (square, rectangular, “O”-ring), mounted stationary in the cylinder bore or on the movable piston of disc brakes.

## 2 Normative references

The following referenced documents are indispensable for the application of this document. For dated references, only the edition cited applies. For undated references, the latest edition of the referenced document (including any amendments) applies.

ISO 48, *Rubber, vulcanized or thermoplastic — Determination of hardness (hardness between 10 IRHD and 100 IRHD)*

ISO 4930:2006

<https://standards.iteh.ai/catalog/standards/sist/79573e5f-1fd4-41be-badc-551671d79864/iso-4930-2006>

ISO 188, *Rubber, vulcanized or thermoplastic — Accelerated ageing and heat resistance tests*

ISO 1817, *Rubber, vulcanized — Determination of the effect of liquids*

ISO 4926, *Road vehicles — Hydraulic brake systems — Non-petroleum base reference fluids*

ISO 4928, *Road vehicles — Elastomeric cups and seals for cylinders for hydraulic braking systems using a non-petroleum base hydraulic brake fluid (Service temperature 120 °C max.)*

## 3 Product requirements

Seals shall conform to the pertinent drawing in all respects, and shall be free from blisters, pin-holes, cracks, protuberances, embedded foreign material, or other physical defects which can be detected by thorough inspection.

These elastomeric seals shall be suitable for operation in a temperature range of –40 °C to +150 °C.

## 4 Brake test fluid

The test fluid for all tests except the test specified in Clause 14 shall be compatibility fluid as defined in ISO 4926. The fluid specified in Clause 14 shall be ISO fluid for storage corrosion test as defined in ISO 4926 or the fluid agreed by the parties concerned.

## 5 Apparatus

### 5.1 Apparatus for test of resistance to fluid at elevated temperature, physical stability and precipitation characteristics

5.1.1 **Oven**, uniformly heated, dry air type conforming to the requirements of ISO 188.

5.1.2 **Test jar**, screw-top straight-sided round glass type, having a capacity of approximately 250 ml and inner dimensions of approximately 125 mm height and 50 mm diameter, with a tinned steel lid (no insert or organic coating).

### 5.2 Apparatus for high-temperature stroking test (see Figure 1)

5.2.1 **Pneumatic or hydraulic pressure source.**

5.2.2 **Master cylinder.**

5.2.3 **Pressure gauge.**

5.2.4 **Wheel cylinder seat stroking fixture.**

5.2.5 **Cylinder assembly.**

5.2.6 **Oven**, in accordance with 5.1.1.

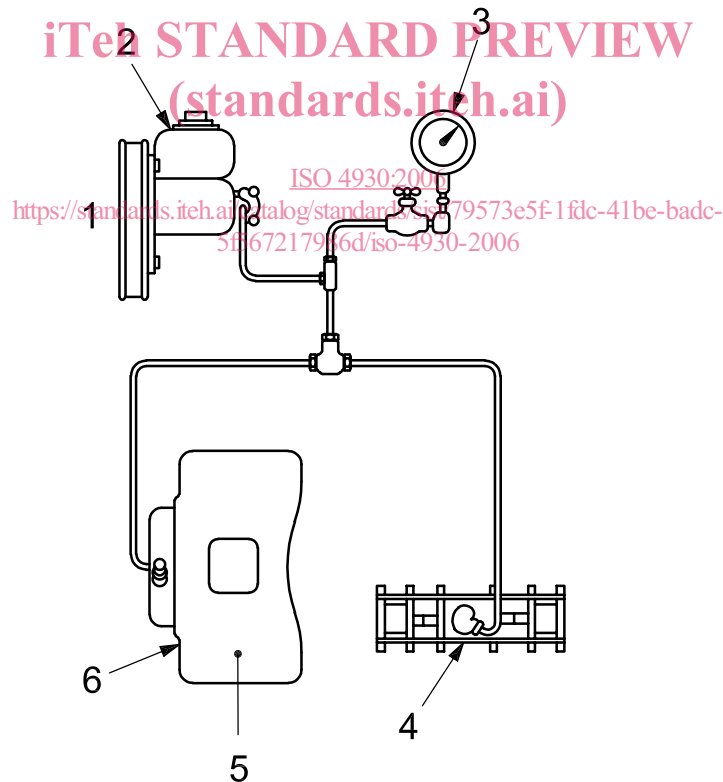

#### Key

- 1 pneumatic or hydraulic pressure source
- 2 master cylinder
- 3 pressure gauge
- 4 wheel cylinder seat stroking fixture
- 5 oven chamber at +120 °C
- 6 cylinder assembly

Figure 1 — High-temperature stroking test

### 5.3 Apparatus for low-temperature leakage test (see Figure 2)

5.3.1 Hydraulic pressure gauge.

5.3.2 Master cylinder.

5.3.3 Cylinder assembly.

5.3.4 Cold chamber, at  $-40\text{ }^{\circ}\text{C}$ .

Dimensions in millimetres

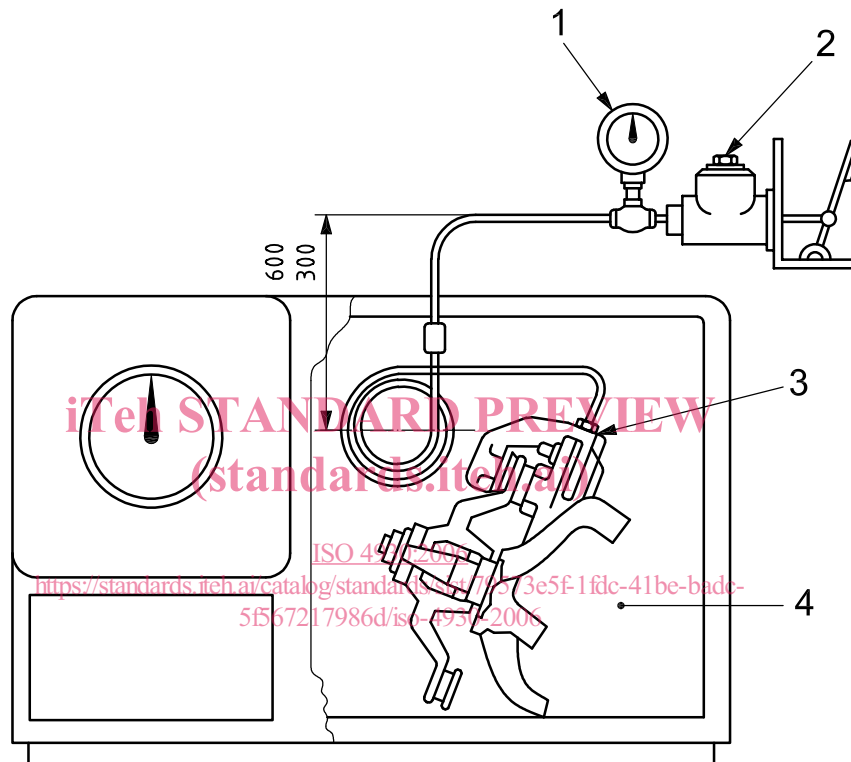

#### Key

- 1 hydraulic pressure gauge
- 2 master cylinder
- 3 cylinder assembly
- 4 cold chamber at  $-40\text{ }^{\circ}\text{C}$

Figure 2 — Low-temperature leakage test

## 6 Test requirements

6.1 After the test for resistance to fluid at elevated temperature (physical stability) (see Clause 8), the seals shall conform to the following requirements:

- a) any change in volume shall be within 0 % to +15 %;
- b) any change in hardness shall be within 0 IRDH to  $-15$  IRHD.

6.2 After the test for resistance to fluid at elevated temperature (precipitation characteristics) (see Clause 9), not more than 0,3 % sediment by volume shall be formed in the test fluid used.

**6.3** After the test for resistance to elevated temperature in dry air (see Clause 10), the seals shall conform to the following requirements:

- a) any change in hardness shall be within 0 IRDH to +15 IRHD;
- b) seal condition: test specimens shall show no evidence of blistering, cracking, or change in shape from the original form.

**6.4** After the ambient temperature stroking test (see Clause 11), seals and assembly shall conform to the following requirements:

- a) no leakage beyond normal wetting of the bore(s) shall occur during the stroking test;
- b) no leakage beyond normal wetting of the bore(s) shall occur during the static leak test (see 11.2.3).

**6.5** After the high temperature stroking test (see Clause 12), the seals and assembly shall conform to the following requirements:

- a) no leakage beyond normal wetting of the bore(s) shall occur during the stroking test;
- b) no leakage beyond normal wetting of the bore(s) shall occur during the static leak test (see 12.2.4).

**6.6** After the low temperature leakage test (see Clause 13), the seals and assembly shall conform to the following requirements:

- a) no leakage beyond normal wetting of the bore(s) shall occur during the test period or pressure application;
- b) the seal shall not crack, shall remain flexible and shall return to its approximate original shape within 1 min when tested according to the procedure specified in 13.3.

**6.7** After the cycling humidity storage corrosion test (Clause 14), the seals and assembly shall conform to the following requirements:

- a) no evidence of rubber adhesion of the test seal(s) shall appear during disassembly of the test brake;
- b) no surface of the sealing systems shall show evidence of corrosion or deterioration which would interfere with proper sealing action; normal staining or discoloration of metal parts is acceptable if surface finish is unaffected.

**6.8** After all tests, disassemble the cylinder and inspect the seal. Record the visual condition of the seal bore and piston. Seals shall not show excessive deterioration such as scoring, scuffing, blistering, cracking, or change in shape from original appearance.

## 7 Preparation of test specimens

All seals to be tested shall be cleaned prior to testing by rinsing in isopropanol then blown dry or wiped dry with a lint-free cloth. Seals shall not remain in the alcohol for more than 30 s.

## 8 Resistance to fluid at elevated temperature

### 8.1 Test specimens

From three or more seals to be tested, obtain a sample of mass 3 g to 5 g.



## 8.2 Test procedure

**8.2.1** Determine and record the initial volume of the sample in accordance with ISO 1817.

**8.2.2** Determine and record the initial hardness of the sample in IRHD. Measure the hardness as specified in ISO 48 using a microtester (or according to a procedure previously agreed upon between the vendor and purchaser).

**8.2.3** Place the sample in the test jar (5.1.2) and completely immerse in 75 ml of brake test fluid (see Clause 4). Seal the test jar to prevent vapour loss and place in the oven (5.1.1) at  $150\text{ °C} \pm 2\text{ °C}$  for 70 h.

**8.2.4** After the 70 h, remove the sample from the oven and allow to cool in the container at  $23\text{ °C} \pm 5\text{ °C}$  for 60 min to 90 min. At the end of the cooling period, remove the sample from the container and rinse in isopropanol or ethanol then wipe dry with a clean, lint-free cloth.

Do not allow the sample to remain in the alcohol for more than 30 s.

**8.2.5** Within 60 min of removal from the liquid, determine and record the final volume and hardness, in IRHD, of each seal in accordance with 8.2.1 and 8.2.2.

Average the results and report as the change in volume and hardness.

**8.2.6** Report the change in volume,  $\Delta V$ , as a percentage of the original volume. It is given by the formula:

$$\Delta V = \frac{(m_3 - m_4) - (m_1 - m_2)}{(m_1 - m_2)} \times 100\%$$

where

- $m_1$  is the initial mass, in grams, in air; [ISO 4930:2006](https://standards.iteh.ai/catalog/standards/sist/79573e5f-1fd4-41be-badc-5f567217986d/iso-4930-2006)
- $m_2$  is the initial apparent mass, in grams, in water;
- $m_3$  is the mass, in grams, in air after immersion in the test fluid;
- $m_4$  is the apparent mass, in grams, in water after immersion in the test fluid.

## 9 Resistance to fluid at elevated temperature – Precipitation characteristics

### 9.1 Test specimens

From two or more seals to be tested, obtain a sample of  $4,0\text{ g} \pm 0,5\text{ g}$ . Since whole seals are quite large, small pieces may be cut from the seal to arrive at the required mass. Use a minimum number of pieces to obtain a sample of mass  $4,0\text{ g} \pm 0,5\text{ g}$ .

### 9.2 Test procedure

**9.2.1** Place the sample in a test jar (5.1.2) and cover it with 75 ml of the test fluid (see Clause 4). Seal the test jar to prevent vapour loss and place in the oven (5.1.1) at  $150\text{ °C} \pm 2\text{ °C}$ . (Optional: a blank test may be conducted on the brake fluid prior to the test, and any sediment resulting from this blank test may be deducted from the volume of sediment obtained after the test.)

**9.2.2** After 70 h, remove the test jar from the oven. Allow the sample to remain in the fluid at room temperature for 24 h, after which agitate the test fluid and pour into a cone-shaped centrifuge tube of 100 ml capacity.