Alpine and touring ski-bindings — Test soles for ski-binding tests

*Fixations de skis alpins et de randonnée — Semelles d'essai pour les
essais de fixations de skis*

iTeh STANDARD PREVIEW
(standards.iteh.ai)

[ISO 9838:2008](https://standards.iteh.ai/catalog/standards/sist/5427d230-83f6-4de9-a713-41972dc0ab3d/iso-9838-2008)

<https://standards.iteh.ai/catalog/standards/sist/5427d230-83f6-4de9-a713-41972dc0ab3d/iso-9838-2008>



PDF disclaimer

This PDF file may contain embedded typefaces. In accordance with Adobe's licensing policy, this file may be printed or viewed but shall not be edited unless the typefaces which are embedded are licensed to and installed on the computer performing the editing. In downloading this file, parties accept therein the responsibility of not infringing Adobe's licensing policy. The ISO Central Secretariat accepts no liability in this area.

Adobe is a trademark of Adobe Systems Incorporated.

Details of the software products used to create this PDF file can be found in the General Info relative to the file; the PDF-creation parameters were optimized for printing. Every care has been taken to ensure that the file is suitable for use by ISO member bodies. In the unlikely event that a problem relating to it is found, please inform the Central Secretariat at the address given below.

iTeh STANDARD PREVIEW
(standards.iteh.ai)

ISO 9838:2008

<https://standards.iteh.ai/catalog/standards/sist/5427d230-83f6-4de9-a713-41972dc0ab3d/iso-9838-2008>



COPYRIGHT PROTECTED DOCUMENT

© ISO 2008

All rights reserved. Unless otherwise specified, no part of this publication may be reproduced or utilized in any form or by any means, electronic or mechanical, including photocopying and microfilm, without permission in writing from either ISO at the address below or ISO's member body in the country of the requester.

ISO copyright office
Case postale 56 • CH-1211 Geneva 20
Tel. + 41 22 749 01 11
Fax + 41 22 749 09 47
E-mail copyright@iso.org
Web www.iso.org

Published in Switzerland

Foreword

ISO (the International Organization for Standardization) is a worldwide federation of national standards bodies (ISO member bodies). The work of preparing International Standards is normally carried out through ISO technical committees. Each member body interested in a subject for which a technical committee has been established has the right to be represented on that committee. International organizations, governmental and non-governmental, in liaison with ISO, also take part in the work. ISO collaborates closely with the International Electrotechnical Commission (IEC) on all matters of electrotechnical standardization.

International Standards are drafted in accordance with the rules given in the ISO/IEC Directives, Part 2.

The main task of technical committees is to prepare International Standards. Draft International Standards adopted by the technical committees are circulated to the member bodies for voting. Publication as an International Standard requires approval by at least 75 % of the member bodies casting a vote.

Attention is drawn to the possibility that some of the elements of this document may be the subject of patent rights. ISO shall not be held responsible for identifying any or all such patent rights.

ISO 9838 was prepared by Technical Committee ISO/TC 83, *Sports and recreational equipment*, Subcommittee SC 3, *Ski bindings*.

This second edition cancels and replaces the first edition (ISO 9838:1991), which has been technically revised.

iTeh STANDARD PREVIEW
(standards.iteh.ai)

ISO 9838:2008
<https://standards.iteh.ai/catalog/standards/sist/5427d230-83f6-4de9-a713-41972dc0ab3d/iso-9838-2008>

iTeh STANDARD PREVIEW
(standards.iteh.ai)

ISO 9838:2008

<https://standards.iteh.ai/catalog/standards/sist/5427d230-83f6-4de9-a713-41972dc0ab3d/iso-9838-2008>

Alpine and touring ski-bindings — Test soles for ski-binding tests

1 Scope

This International Standard defines test soles representing

- an alpine ski-boot (form A), or at least the bottom part of it, to be used for testing alpine ski-bindings for alpine skiing in accordance with ISO 9462 and ISO 9465

and

- a touring ski-boot (form T), or at least the bottom part of it, to be used for testing touring ski-bindings for touring skiing in accordance with ISO 13992 and ISO 9465.

NOTE Ski-boots have their own International Standards (ISO 5355 and ISO 9523) that allow relatively large tolerances in defining the test sole, which are generally believed to be suitable for on-slope use by skiers but too large for reproducible laboratory measurements.

2 Normative references

[ISO 9838:2008](https://standards.iteh.ai/catalog/standards/sist/5427d230-83f6-4de9-a713-41472dc0150/iso-9838-2008)

The following referenced documents are indispensable for the application of this document. For dated references, only the edition cited applies. For undated references, the latest edition of the referenced document (including any amendments) applies.

ISO 868, *Plastics and ebonite — Determination of indentation hardness by means of a durometer (Shore hardness)*

ISO 5355, *Alpine ski-boots — Requirements and test methods*

ISO 9462, *Alpine ski-bindings — Requirements and test methods*

ISO 9465, *Alpine ski-bindings — Lateral release under impact loading — Test method*

ISO 13992, *Alpine touring ski-bindings — Requirements and test methods*

3 Terms and definitions

For the purposes of this document, the terms and definitions given in ISO 5355 and the following apply.

3.1

test sole form A

test sole for testing alpine ski bindings

3.2

test sole form T

test sole for testing touring ski bindings

3.3

test sole type A

test sole for adults in accordance with ISO 5355, type A, suitable for bindings of type A (adults) and CA (junior) in accordance with ISO 9462

3.4

test sole type C

test sole for children in accordance with ISO 5355, type C, suitable for bindings of type C (children) in accordance with ISO 9462

3.5

basic test sole

one-piece sole of length 305 mm for type A and 255 mm for type C

3.6

variable length soles

sole that is either adjustable, in two parts, or a set of several fixed length soles – between 270 mm and 360 mm for type A and between 200 mm and 280 mm for type C

4 Material and manufacture

The sole shall be moulded in polyurethane (TPU), reinforced by a metal insert in order to achieve the mechanical requirements given in Clause 6. It is moulded in a homogeneous material and in a mould with the same roughness on the sole/binding interface to ensure that the friction coefficient is the same all over this interface.

In the shell areas, reinforcement is allowed to support the walls. It should remain outside the flat area.

Form T could be based, for example, on the same construction as form A type A with the addition of a TPU part to allow tooling of the defined profile in Figure 3 and glueing of a thick rubber sole of hardness 75 ± 3 Shore A. The dimensions of test sole form T, which are not given in Figure 3, shall be taken from test sole form A type A, shown in Figure 1.

5 Dimensions

The dimensions of the basic sole shall be as shown in Figures 1, 2 and 3. Except for the overall length, all the dimensions also apply to the variable length soles subject to the tolerance in Table 1.

Table 1 — Tolerance

Dimensions in millimetres

Dimension	Tolerance for nominal dimension of				
	0,5 to 3	> 3 to 6	> 6 to 30	> 30 to 120	> 120 to 315
Length dimensions	$\pm 0,15$	$\pm 0,2$	$\pm 0,5$	$\pm 0,8$	$\pm 1,2$
Radius and chamfer	$\pm 0,2$	$\pm 0,5$	± 1	± 2	—

Dimensions in millimetres

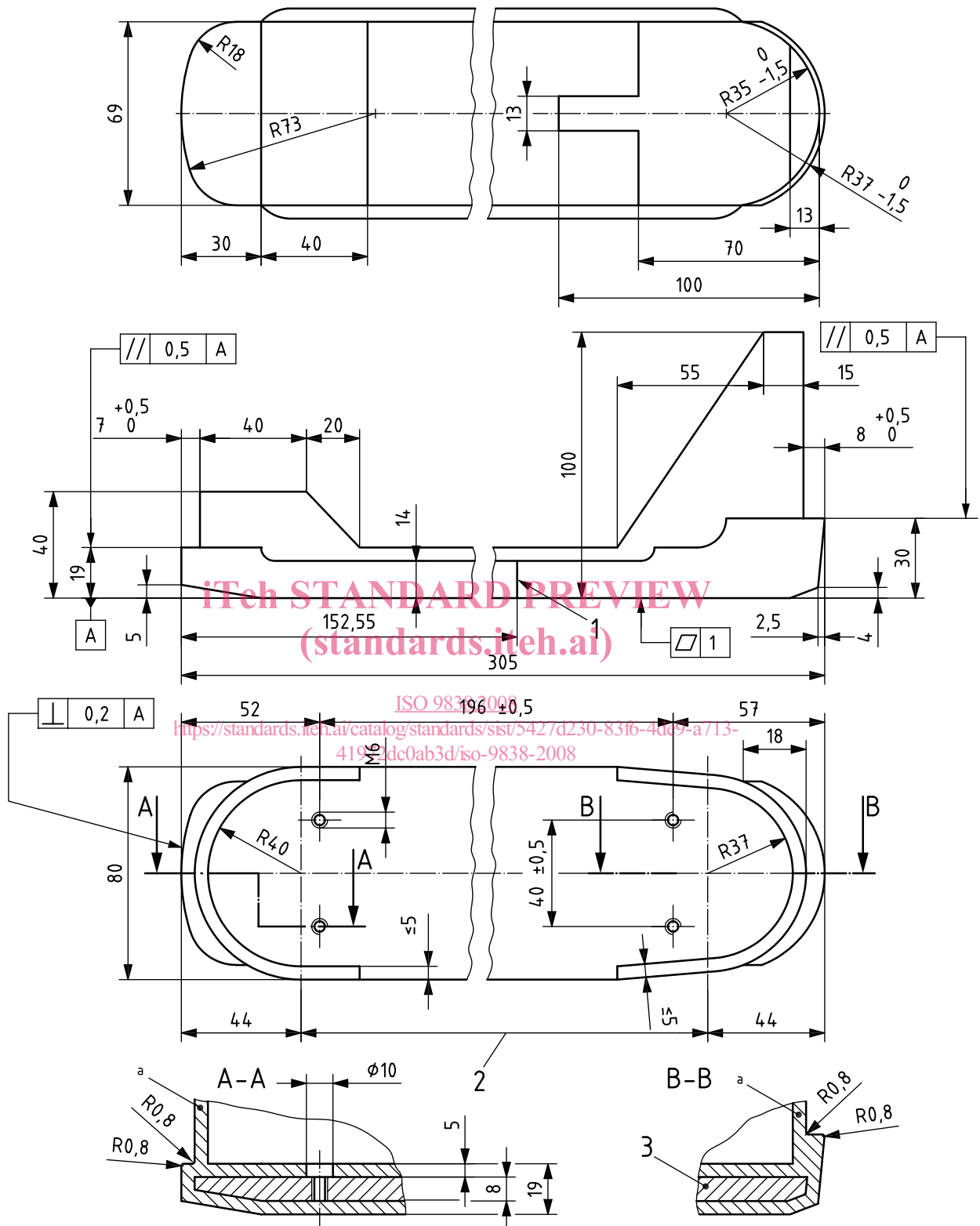

Key

- 1 central mark
- 2 flat area
- 3 reinforcement plate
- a See Clause 4.

Figure 1 — Test sole form A type A

Dimensions in millimetres

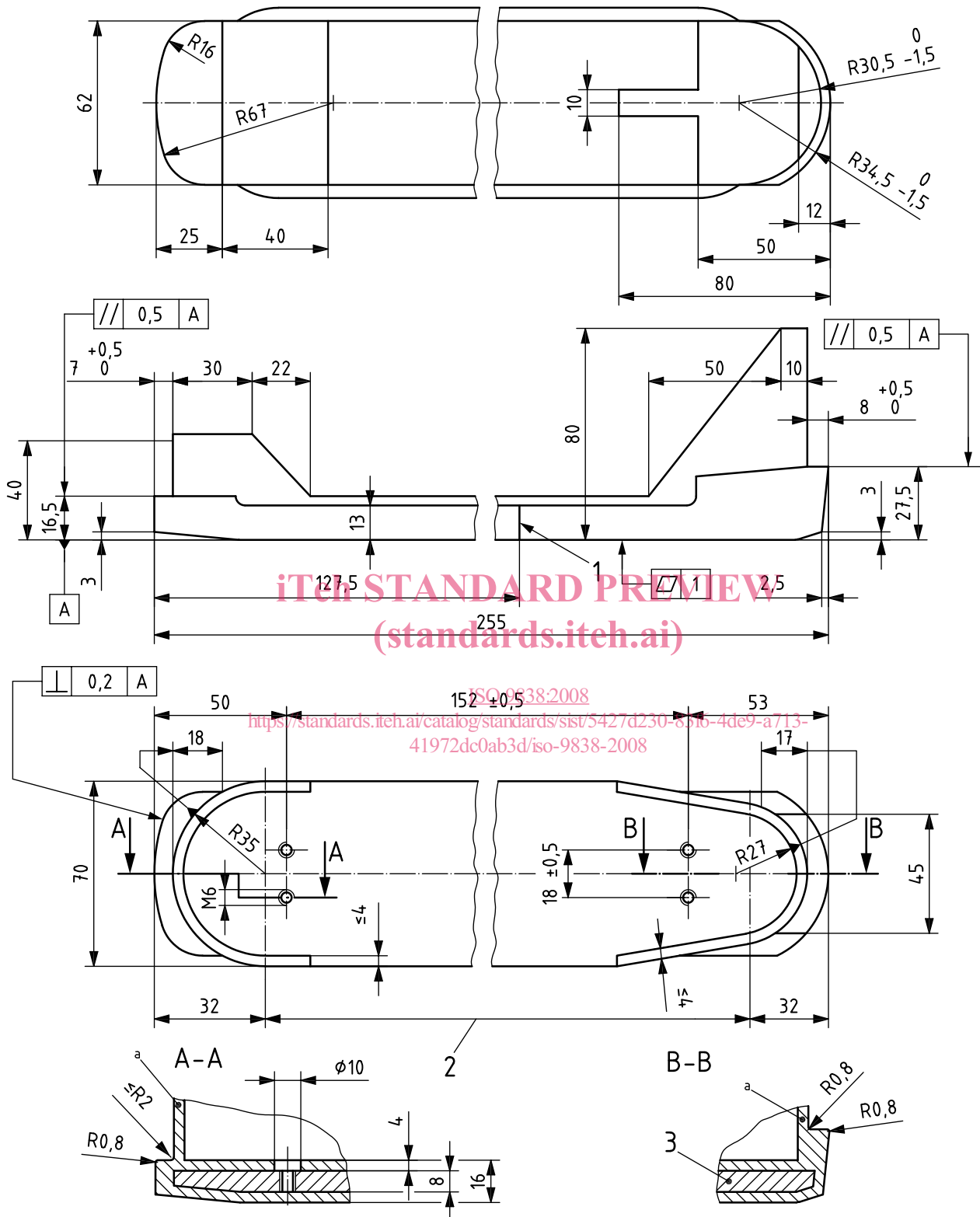

Key

- 1 central mark
- 2 flat area
- 3 reinforcement plate
- a See Clause 4.

Figure 2 — Test sole form A type C

Dimensions in millimetres

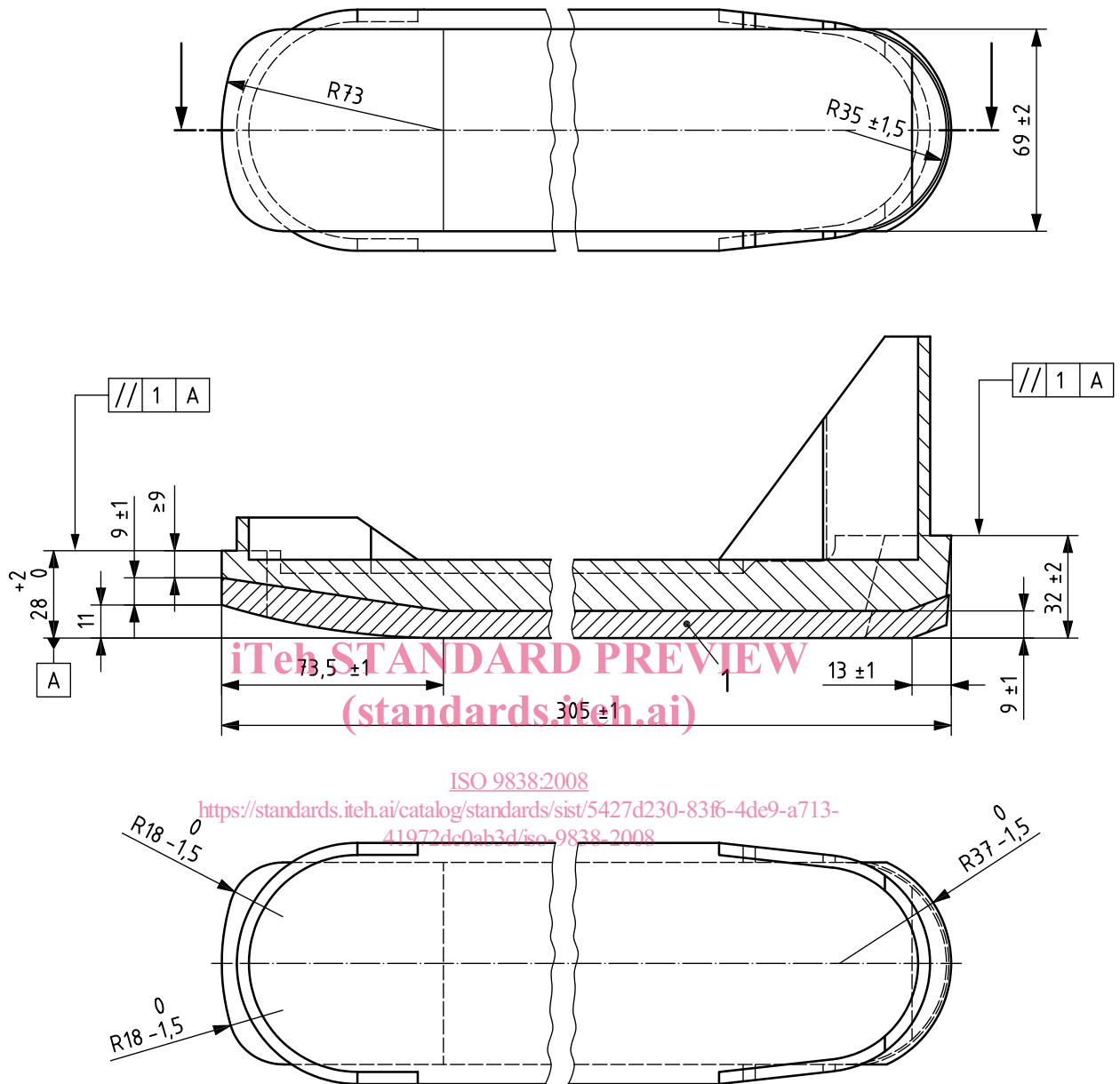

Key

- 1 75 ± 3 Shore A rubber layer

Figure 3 — Test sole form T