

---

---

**Testing of concrete —**

Part 9:

**Determination of creep of concrete  
cylinders in compression**

*Essais du béton —*

*Partie 9: Détermination du fluage de cylindres de béton en compression*  
**(standards.iteh.ai)**

ISO 1920-9:2009

<https://standards.iteh.ai/catalog/standards/sist/b253d995-4580-4ce5-99f5-47c9a302d68b/iso-1920-9-2009>



Reference number  
ISO 1920-9:2009(E)

**PDF disclaimer**

This PDF file may contain embedded typefaces. In accordance with Adobe's licensing policy, this file may be printed or viewed but shall not be edited unless the typefaces which are embedded are licensed to and installed on the computer performing the editing. In downloading this file, parties accept therein the responsibility of not infringing Adobe's licensing policy. The ISO Central Secretariat accepts no liability in this area.

Adobe is a trademark of Adobe Systems Incorporated.

Details of the software products used to create this PDF file can be found in the General Info relative to the file; the PDF-creation parameters were optimized for printing. Every care has been taken to ensure that the file is suitable for use by ISO member bodies. In the unlikely event that a problem relating to it is found, please inform the Central Secretariat at the address given below.

**iTeh STANDARD PREVIEW**  
**(standards.iteh.ai)**

ISO 1920-9:2009

<https://standards.iteh.ai/catalog/standards/sist/b253d995-4580-4ce5-99f5-47c9a302d68b/iso-1920-9-2009>



**COPYRIGHT PROTECTED DOCUMENT**

© ISO 2009

All rights reserved. Unless otherwise specified, no part of this publication may be reproduced or utilized in any form or by any means, electronic or mechanical, including photocopying and microfilm, without permission in writing from either ISO at the address below or ISO's member body in the country of the requester.

ISO copyright office  
Case postale 56 • CH-1211 Geneva 20  
Tel. + 41 22 749 01 11  
Fax + 41 22 749 09 47  
E-mail [copyright@iso.org](mailto:copyright@iso.org)  
Web [www.iso.org](http://www.iso.org)

Published in Switzerland

## Foreword

ISO (the International Organization for Standardization) is a worldwide federation of national standards bodies (ISO member bodies). The work of preparing International Standards is normally carried out through ISO technical committees. Each member body interested in a subject for which a technical committee has been established has the right to be represented on that committee. International organizations, governmental and non-governmental, in liaison with ISO, also take part in the work. ISO collaborates closely with the International Electrotechnical Commission (IEC) on all matters of electrotechnical standardization.

International Standards are drafted in accordance with the rules given in the ISO/IEC Directives, Part 2.

The main task of technical committees is to prepare International Standards. Draft International Standards adopted by the technical committees are circulated to the member bodies for voting. Publication as an International Standard requires approval by at least 75 % of the member bodies casting a vote.

Attention is drawn to the possibility that some of the elements of this document may be the subject of patent rights. ISO shall not be held responsible for identifying any or all such patent rights.

ISO 1920-9 was prepared by Technical Committee ISO/TC 71, *Concrete, reinforced concrete and pre-stressed concrete*, Subcommittee SC 1, *Test methods for concrete*.

ISO 1920 consists of the following parts, under the general title *Testing of concrete*:

- iTeh STANDARD PREVIEW**  
(standards.iteh.ai)
- *Part 1: Sampling of fresh concrete*
  - *Part 2: Properties of fresh concrete* [ISO 1920-9:2009](https://standards.iteh.ai/catalog/standards/sist/b253d995-4580-4ce5-99f5-47c9a302d68b/iso-1920-9-2009)
  - *Part 3: Making and curing test specimens*
  - *Part 4: Strength of hardened concrete*
  - *Part 5: Properties of hardened concrete other than strength*
  - *Part 6: Sampling, preparing and testing of concrete cores*
  - *Part 7: Non-destructive tests on hardened concrete*
  - *Part 8: Determination of drying shrinkage of concrete for samples prepared in the field or in the laboratory*
  - *Part 9: Determination of creep of concrete cylinders in compression*
- The following part is under preparation:
- *Part 10: Determination of static modulus of elasticity in compression*

**iTeh STANDARD PREVIEW**  
**(standards.iteh.ai)**

ISO 1920-9:2009

<https://standards.iteh.ai/catalog/standards/sist/b253d995-4580-4ce5-99f5-47c9a302d68b/iso-1920-9-2009>

# Testing of concrete —

## Part 9:

# Determination of creep of concrete cylinders in compression

## 1 Scope

This part of ISO 1920 specifies a method for determining the creep of standard concrete test cylinders subjected to a sustained longitudinal compressive load.

**NOTE** The conditions for curing and storage (see 6.1) can be varied to suit different requirements, e.g. early pre-stress. The time of loading (see 6.2) can also be varied to give an indication of other properties. These variations, however, will not conform to the requirements for a creep test as specified in this part of ISO 1920 and it is necessary that any deviation from the standard procedure be recorded in the test report.

## 2 Normative references

The following referenced documents are essential for the application of this document. For dated references, only the edition cited applies. For undated references, the latest edition of the referenced document (including any amendments) applies.

ISO 1920-3:2004, *Testing of concrete — Part 3: Making and curing test specimens*

ISO 1920-4:2005, *Testing of concrete — Part 4: Strength of hardened concrete*

ISO 1920-8:2009, *Testing of concrete — Part 8: Determination of drying shrinkage of concrete for samples prepared in the field or in the laboratory*

## 3 Principle

The creep of the concrete is obtained by determining the total combined creep and drying shrinkage of the loaded specimens and subtracting from this value the drying shrinkage of the unloaded specimens, all specimens being stored in the same environmental conditions. This part of ISO 1920 details the fixed environmental conditions for carrying out the test, which allows comparison with previously tested specimens and specimens tested in other laboratories.

## 4 Apparatus

**4.1 Loading frame**, capable of applying and maintaining the required load on the specimen or group of specimens for the duration of the test. The means of maintaining the load may be either a spring or system of springs; alternatively, a hydraulic ram or capsule may be used.

A schematic diagram of a loading frame operated by a hydraulic arrangement is given in Figure 1. A similar arrangement can also be used for a spring-loaded system in which the system of loading only will be different.

**NOTE** The arrangement shown in Figure 1 employs the vertical loading of specimens. Horizontal loading of specimens is also frequently employed.

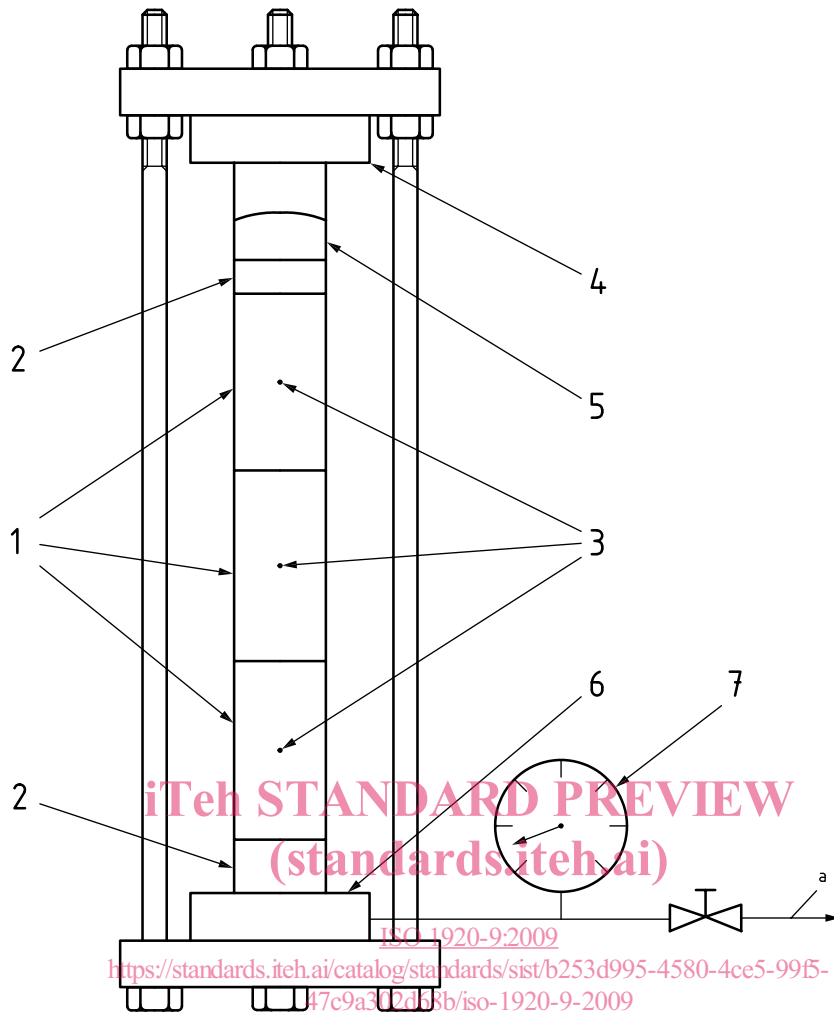

**Key**

- 1 test cylinders
- 2 end plates
- 3 gauge reference points
- 4 load cell
- 5 hemispherical seat
- 6 load sustaining cell
- 7 pressure gauge

a To pump.

**Figure 1 — Schematic arrangement for testing creep of concrete**

Where the load-maintaining system comprises a spring or a system of springs, initial compression shall be applied by means of a portable jack or testing machine.

Where a system of springs is used for load maintenance, care should be taken in the selection of springs, which should be long and suitably matched for the purpose.

Means shall be provided for measuring the load to the nearest 2 % of the total applied load. Suitable means of measuring the load are by

- a) a permanently installed hydraulic load cell with calibrated pressure gauge,
- b) a calibrated hydraulic jack with pressure gauge, or
- c) a calibrated load cell inserted in the frame at the time of loading or when the load is adjusted.

All end plates of the loading frame shall be sufficiently rigid to ensure uniform loading of the cylinders. At one end of the specimen or group of specimens a suitable spherical seating device shall be provided between the specimens and the end plates. Bearing surfaces of any plates in contact with the loaded specimens shall not depart from a plane by more than 0,05 mm.

In any loading frame, a group of specimens may be stacked for simultaneous loading.

**4.2 Strain-measuring device**, which meets the following requirements.

- a) A suitable apparatus shall be provided for the measurement of longitudinal strain in each specimen to the nearest 10 microstrain. The apparatus may be attached or portable. In all cases, reference gauge points shall be positively attached to the specimen. Gauges relying on friction contact shall not be used.
- b) Deformations shall be measured on gauge lines spaced uniformly around the periphery of the specimen. The gauge reference points shall be evenly spaced at about the mid-height of the specimen. The number of gauge lines shall be not less than two for control specimens and not less than three for loaded specimens.
- c) The effective gauge length shall be not less than three times the maximum aggregate size and not greater than
  - 1) 260 mm for large specimens without end plates, and 160 mm for small specimens without end plates, and
  - 2) 150 mm for large specimens having attached end plates, and 100 mm for small specimens having attached end plates.

NOTE 1 A "small specimen" made of concrete is one having the maximum nominal size of the aggregate not greater than 25 mm, while a "large specimen" made of concrete is one having the maximum nominal size of the aggregate greater than 25 mm.

- d) The strain-measuring device shall be capable of measuring the range of strains over one year without change in calibration.

NOTE 2 Systems in which the varying strains are compared with a constant-length standard bar are considered the most reliable.

## 5 Test specimens

### 5.1 General

Cylinders of 100 mm diameter may be used for creep determinations, but the specimen size shall be selected so that requirements in respect to maximum aggregate size given in ISO 1920-3:2005, 4.1, are satisfied. Test specimens shall be moulded cylinders prepared in accordance with ISO 1920-3, and the cylinders shall conform to ISO 1920-4:2005, 3.1.

## 5.2 Number of specimens

For each test condition, not less than nine cylinders of the same size shall be made from a given batch of concrete. Of these cylinders, a minimum of

- a) three shall be tested for compressive strength,
- b) three shall be loaded and observed for deformation, and
- c) three shall remain unloaded for use as controls for deformations from causes other than loads.

## 5.3 End preparation

Specimens that are perpendicular to the axis within  $\pm 0,5^\circ$  may be capped or used against end plates. Specimens beyond this tolerance shall be sawn and re-checked for conformity prior to capping or use with end plates.

The ends of specimens shall meet the plainness requirements of ISO 1920-4.

**IMPORTANT — The alignment of the axes of the individual specimens is critical and the end preparation necessary to achieve this alignment is likewise critical. Great care must be exercised in achieving the plainness and perpendicularity within the tolerances specified. The requirements for plainness and perpendicularity may be met by capping with Portland cement mortar or sulfur, by lapping, or at the time of casting by fitting the ends with steel bearing plates normal to the axis of the specimen. The necessary axiality may also be achieved by bonding the specimens together with a thin layer of epoxy resin using a suitable jig.**

## 5.4 Fixing gauge points

Gauge points shall be cast-in or fixed to the creep and control specimens prior to testing.

Where gauge points are to be attached to the surface of specimens, this should be done in sufficient time to allow checking of their stability prior to the time of loading.

# 6 Procedure

## 6.1 Curing and storage

### 6.1.1 General

The duration of curing and storage of all specimens (creep, control and compression test specimens) prior to loading shall be 28 days. This shall consist of

- a) initial curing conditions for  $24\text{ h} \pm 4\text{ h}$  (see 6.1.2),
- b) standard moist curing conditions to age 7 days (see 6.1.3), and
- c) standard drying conditions to age 28 days (see 6.1.4).

The storage of loaded and control specimens shall be carried out under standard drying conditions.

### 6.1.2 Initial curing conditions

Specimens shall be stored undisturbed in their moulds on a rigid horizontal surface in the relevant conditions required in ISO 1920-3:2004, Clause 7.

The storage period shall be not less than 20 h or more than 28 h under these conditions.



### 6.1.3 Standard moist curing conditions

Standard moist curing conditions shall be in accordance with the requirements for standard moist curing specified in ISO 1920-3.

### 6.1.4 Standard drying conditions

Standard drying conditions shall be in accordance with ISO 1920-8:2009, 5.1.

## 6.2 Measurement

The procedure for the measurement of strain is as follows.

- a) On the same day that the creep specimens are loaded, determine the compressive strength of the concrete on at least three companion specimens, in accordance with ISO 1920-4.
- b) Determine the stress to be applied to the test specimens. The stress shall not exceed one-third of the average compressive strength as determined in a) above. Lower levels of stress are permitted when specified. Where the stress is not one-third of the average compressive strength, this fact and the actual load shall be recorded in the test report.
- c) Prior to the creep specimens being placed in the loading frame, seal each end of the control specimens to prevent loss of moisture from these surfaces.

NOTE Loss of moisture from the end surfaces of control specimens can be prevented by covering the ends with a coating of epoxy resin or other sealant that will remain effective for the duration of the test.

- d) Place the creep test specimens with gauge points attached in the loading frame and align the specimens so as to even the load as much as possible.

In placing creep specimens in the frame, care should be taken in aligning the specimens to avoid eccentric loading. When cylinders are stacked and external gauges are used, it may be helpful to apply a small preload such that the resultant stress does not exceed 1 MPa and note the strain variation around each specimen, after which the load may be removed and the specimens realigned for greater strain uniformity.

- e) Apply the predetermined stress from b) above at the same loading rate as that specified in ISO 1920-4. Measure and record the strain values immediately before the loading and during 30 s after the loading. In addition, measure and record strain values for the control specimens immediately after strain values have been taken on the loaded specimens. Maintain the level of loading to within  $\pm 2\%$  throughout the duration of the test.
- f) In subsequent strain measurements, the following procedure shall be adopted.
  - 1) Measure the load and if the load differs more than 2 % from the applied load, adjust it to the required value.
  - 2) Determine the strain values at the following times after initial loading:
    - i) at 2 h and at 6 h, then once daily for one week;
    - ii) once a week until the end of one month;
    - iii) once a month thereafter for a total of at least three months.
  - 3) Additional to the above, the strain values may be determined at other times. In such cases, the time shall be recorded and reported.

Where springs are used to maintain the load, the adjustment can be accomplished by applying the correct load and tightening the nuts on the threaded reaction rods.