

INTERNATIONAL STANDARD

ISO
286-1

First edition
1988-09-15



INTERNATIONAL ORGANIZATION FOR STANDARDIZATION
ORGANISATION INTERNATIONALE DE NORMALISATION
МЕЖДУНАРОДНАЯ ОРГАНИЗАЦИЯ ПО СТАНДАРТИЗАЦИИ

ISO system of limits and fits —

Part 1: Bases of tolerances, deviations and fits

iteh STANDARD PREVIEW
(standards.iteh.ai)

Système ISO de tolérances et d'ajustements —

Partie 1: Base des tolérances, écarts et ajustements [ISO 286-1:1988](#)

<https://standards.iteh.ai/catalog/standards/sist/48bb53a9-a9e0-42a6-9400-1ffd1e900ce6/iso-286-1-1988>

Reference number
ISO 286-1:1988 (E)

Foreword

ISO (the International Organization for Standardization) is a worldwide federation of national standards bodies (ISO member bodies). The work of preparing International Standards is normally carried out through ISO technical committees. Each member body interested in a subject for which a technical committee has been established has the right to be represented on that committee. International organizations, governmental and non-governmental, in liaison with ISO, also take part in the work.

Draft International Standards adopted by the technical committees are circulated to the member bodies for approval before their acceptance as International Standards by the ISO Council. They are approved in accordance with ISO procedures requiring at least 75 % approval by the member bodies voting.

This part of ISO 286 has been prepared by ISO/TC 3, *Limits and fits*, and, together with ISO 286-2, completes the revision of ISO/R 286, *ISO system of limits and fits*. ISO/R 286 was first published in 1962 and subsequently confirmed in November 1964; it was based on ISA Bulletin 25 first published in 1940.

The major changes incorporated in this part of ISO 286 are as follows:

- a) The presentation of the information has been modified so that ISO 286 can be used directly in both the design office and the workshop. This has been achieved by separating the material dealing with the bases of the system, and the calculated values of standard tolerances and fundamental deviations, from the tables giving specific limits of the most commonly used tolerances and deviations.
- b) The new symbols j_s and J_S replace the former symbols j_s and J_S (i.e. s and S are no longer placed as subscripts) to facilitate the use of the symbols on equipment with limited character sets, e.g. computer graphics. The letters "s" and "S" stand for "symmetrical deviation".
- c) Standard tolerances and fundamental deviations have been included for basic sizes from 500 to 3 150 mm as standard requirements (these were previously included on an experimental basis only).
- d) Two additional standard tolerance grades, IT17 and IT18, have been included.
- e) Standard tolerance grades IT01 and IT0 have been deleted from the main body of this part of ISO 286, although information on these grades is given in annex A for users who may have a requirement for such grades.
- f) Inch values have been deleted.
- g) The principles, terminology and symbols have been aligned with those required by contemporary technology.

Users should note that all International Standards undergo revision from time to time and that any reference made herein to any other International Standard implies its latest edition, unless otherwise stated.

Contents

	Page
0 Introduction	1
1 Scope	1
2 Field of application	1
3 References	1
4 Terms and definitions	2
5 Symbols, designation and interpretation of tolerances, deviations and fits	6
6 Graphical representation	9
7 Reference temperature	10
8 Standard tolerances for basic sizes up to 3 150 mm	10
9 Fundamental deviations for basic sizes up to 3 150 mm	10
10 Bibliography	16
Annexes	
A Bases of the ISO system of limits and fits	17
B Examples of the use of ISO 286-1	23
C Equivalent terms	24

iTeh STANDARD PREVIEW
(standards.iteh.ai)

<https://standards.iteh.ai/catalog/standards/sist/48bb53a9-a9e0-42a6-9400-1811e900ce6/iso-286-1-1988>

iTeh STANDARD PREVIEW
(standards.iteh.ai)

This page intentionally left blank

ISO 286-1:1988

<https://standards.iteh.ai/catalog/standards/sist/48bb53a9-a9e0-42a6-9400-1ffd1e900ce6/iso-286-1-1988>

ISO system of limits and fits —

Part 1: Bases of tolerances, deviations and fits

0 Introduction

The need for limits and fits for machined workpieces was brought about mainly by the inherent inaccuracy of manufacturing methods, coupled with the fact that "exactness" of size was found to be unnecessary for most workpieces. In order that function could be satisfied, it was found sufficient to manufacture a given workpiece so that its size lay within two permissible limits, i.e. a tolerance, this being the variation in size acceptable in manufacture.

Similarly, where a specific fit condition is required between mating workpieces, it is necessary to ascribe an allowance, either positive or negative, to the basic size to achieve the required clearance or interference, i.e. a "deviation".

With developments in industry and international trade, it became necessary to develop formal systems of limits and fits firstly at the industrial level, then at the national level and later at the international level.

This International Standard therefore gives the internationally accepted system of limits and fits.

Annexes A and B give the basic formulae and rules necessary for establishing the system, and examples in the use of the standard are to be regarded as an integral part of the standard.

Annex C gives a list of equivalent terms used in ISO 286 and other International Standards on tolerances.

1 Scope

This part of ISO 286 gives the bases of the ISO system of limits and fits together with the calculated values of the standard tolerances and fundamental deviations. These values shall be taken as authoritative for the application of the system (see also clause A.1).

This part of ISO 286 also gives terms and definitions together with associated symbols.

2 Field of application

The ISO system of limits and fits provides a system of tolerances and deviations suitable for plain workpieces.

For simplicity and also because of the importance of cylindrical workpieces of circular section, only these are referred to explicitly. It should be clearly understood, however, that the tolerances and deviations given in this International Standard equally apply to workpieces of other than circular section.

In particular, the general term "hole" or "shaft" can be taken as referring to the space contained by (or containing) the two parallel faces (or tangent planes) of any workpiece, such as the width of a slot or the thickness of a key.

The system also provides for fits between mating cylindrical features or fits between workpieces having features with parallel faces, such as the fit between a key and keyway, etc.

NOTE — It should be noted that the system is not intended to provide fits for workpieces with features having other than simple geometric forms.

For the purposes of this part of ISO 286, a simple geometric form consists of a cylindrical surface area or two parallel planes.

3 References

NOTE — See also clause 10.

ISO 1, *Standard reference temperature for industrial length measurements.*

ISO 286-2, *ISO system of limits and fits — Part 2: Tables of standard tolerance grades and limit deviations for holes and shafts.*

ISO/R 1938, *ISO system of limits and fits — Inspection of plain workpieces.*¹⁾

ISO 8015, *Technical drawings — Fundamental tolerancing principle.*

1) At present under revision.

4 Terms and definitions

For the purposes of this International Standard, the following terms and definitions apply. It should be noted, however, that some of the terms are defined in a more restricted sense than in common usage.

4.1 shaft: A term used, according to convention, to describe an external feature of a workpiece, including features which are not cylindrical (see also clause 2).

4.1.1 basic shaft: Shaft chosen as a basis for a shaft-basis system of fits (see also 4.11.1).

For the purposes of the ISO system of limits and fits, a shaft the upper deviation of which is zero.

4.2 hole: A term used, according to convention, to describe an internal feature of a workpiece, including features which are not cylindrical (see also clause 2).

4.2.1 basic hole: Hole chosen as a basis for a hole-basis system of fits (see also 4.11.2).

For the purposes of the ISO system of limits and fits, a hole the lower deviation of which is zero.

4.3 size: A number expressing, in a particular unit, the numerical value of a linear dimension.

4.3.1 basic size; nominal size: The size from which the limits of size are derived by the application of the upper and lower deviations (see figure 1).

NOTE — The basic size can be a whole number or a decimal number, e.g. 32; 15; 8,75; 0,5; etc.

4.3.2 actual size: The size of a feature, obtained by measurement.

4.3.2.1 actual local size: Any individual distance at any cross-section of a feature, i.e. any size measured between any two opposite points.

4.3.3 limits of size: The two extreme permissible sizes of a feature, between which the actual size should lie, the limits of size being included.

4.3.3.1 maximum limit of size: The greatest permissible size of a feature (see figure 1).

4.3.3.2 minimum limit of size: The smallest permissible size of a feature (see figure 1).

4.4 limit system: A system of standardized tolerances and deviations.

4.5 zero line: In a graphical representation of limits and fits, the straight line, representing the basic size, to which the deviations and tolerances are referred (see figure 1).

According to convention, the zero line is drawn horizontally, with positive deviations shown above and negative deviations below (see figure 2).

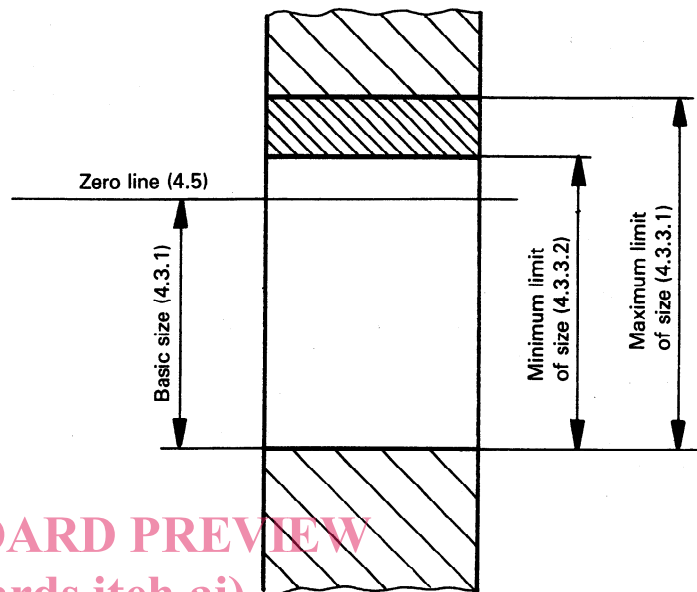

Figure 1 — Basic size, and maximum and minimum limits of size

4.6 deviation: The algebraic difference between a size (actual size, limit of size, etc.) and the corresponding basic size.

NOTE — Symbols for shaft deviations are lower case letters (*es*, *ei*) and symbols for hole deviations are upper case letters (*ES*, *EI*) (see figure 2).

4.6.1 limit deviations: Upper deviation and lower deviation.

4.6.1.1 upper deviation (*ES*, *es*): The algebraic difference between the maximum limit of size and the corresponding basic size (see figure 2).

4.6.1.2 lower deviation (*EI*, *ei*): The algebraic difference between the minimum limit of size and the corresponding basic size (see figure 2).

4.6.2 fundamental deviation: For the purposes of the ISO system of limits and fits, that deviation which defines the position of the tolerance zone in relation to the zero line (see figure 2).

NOTE — This may be either the upper or lower deviation, but, according to convention, the fundamental deviation is the one nearest the zero line.

4.7 size tolerance: The difference between the maximum limit of size and the minimum limit of size, i.e. the difference between the upper deviation and the lower deviation.

NOTE — The tolerance is an absolute value without sign.

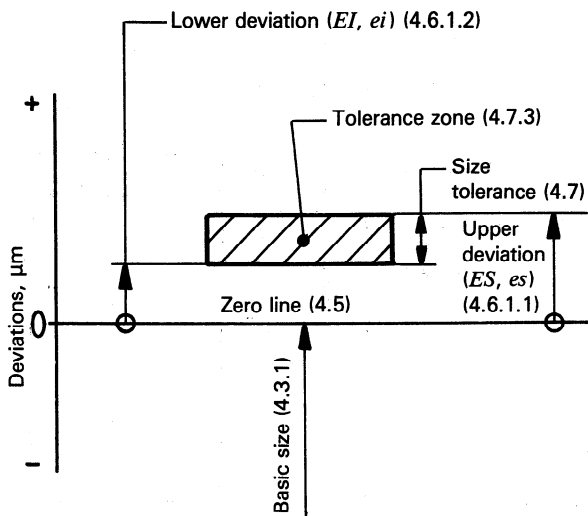

Figure 2 — Conventional representation of a tolerance zone

4.7.1 standard tolerance (IT): For the purposes of the ISO system of limits and fits, any tolerance belonging to this system.

NOTE — The letters of the symbol IT stand for "International Tolerance" grade.

4.7.2 standard tolerance grades: For the purposes of the ISO system of limits and fits, a group of tolerances (e.g. IT7), considered as corresponding to the same level of accuracy for all basic sizes.

4.7.3 tolerance zone: In a graphical representation of tolerances, the zone, contained between two lines representing the maximum and minimum limits of size, defined by the magnitude of the tolerance and its position relative to the zero line (see figure 2).

4.7.4 tolerance class: The term used for a combination of fundamental deviation and a tolerance grade, e.g. h9, D13, etc.

4.7.5 standard tolerance factor (i, I): For the purposes of the ISO system of limits and fits, a factor which is a function of the basic size, and which is used as a basis for the determination of the standard tolerances of the system.

NOTES

- 1 The standard tolerance factor *i* is applied to basic sizes less than or equal to 500 mm.
- 2 The standard tolerance factor *I* is applied to basic sizes greater than 500 mm.

4.8 clearance: The positive difference between the sizes of the hole and the shaft, before assembly, when the diameter of the shaft is smaller than the diameter of the hole (see figure 3).

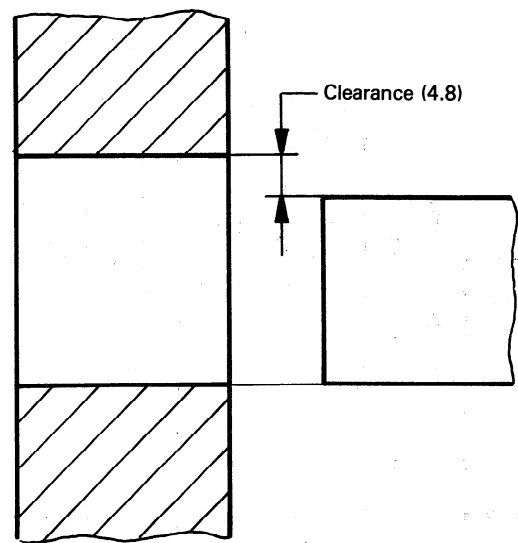

Figure 3 — Clearance

4.8.1 minimum clearance: In a clearance fit, the positive difference between the minimum limit of size of the hole and the maximum limit of size of the shaft (see figure 4).

4.8.2 maximum clearance: In a clearance or transition fit, the positive difference between the maximum limit of size of the hole and the minimum limit of size of the shaft (see figures 4 and 5).

4.9 interference: The negative difference between the sizes of the hole and the shaft, before assembly, when the diameter of the shaft is larger than the diameter of the hole (see figure 6).

4.9.1 minimum interference: In an interference fit, the negative difference, before assembly, between the maximum limit of size of the hole and the minimum limit of size of the shaft (see figure 7).

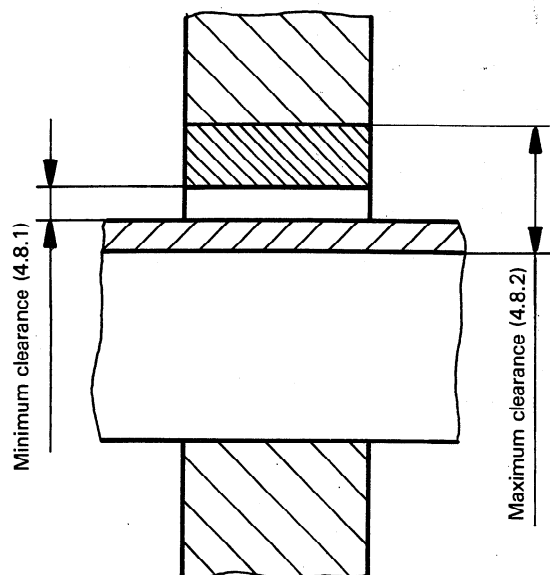

Figure 4 — Clearance fit

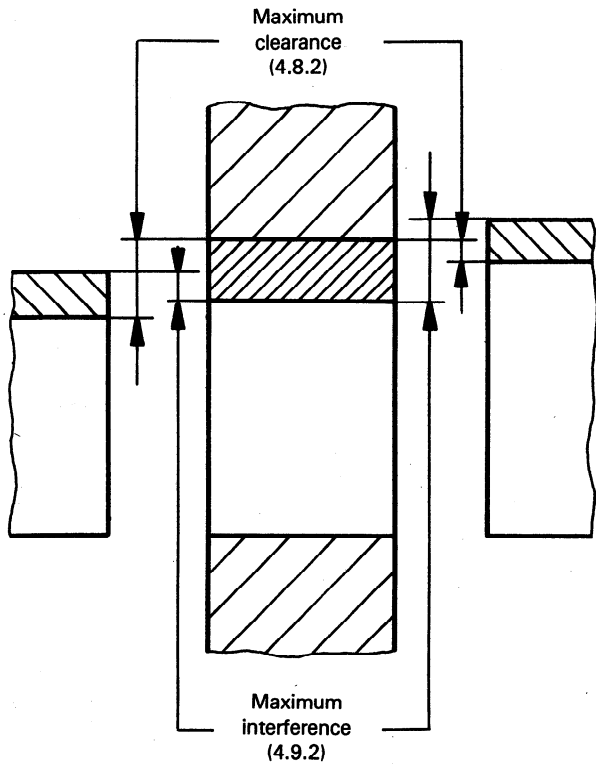

Figure 5 – Transition fit

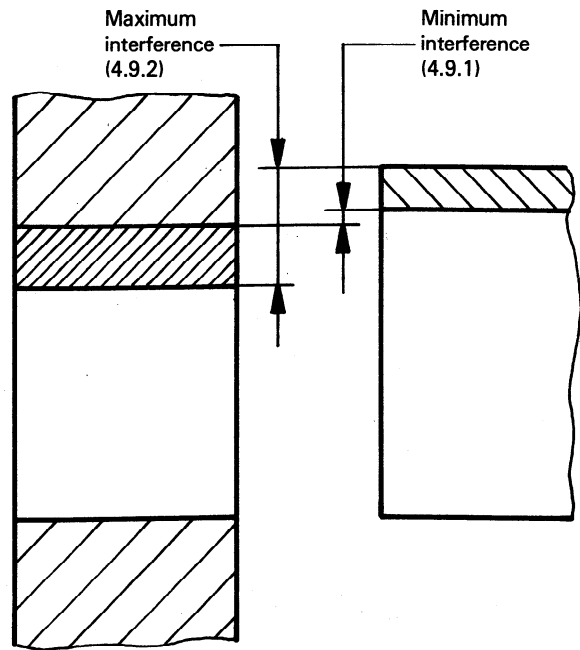

Figure 7 – Interference fit

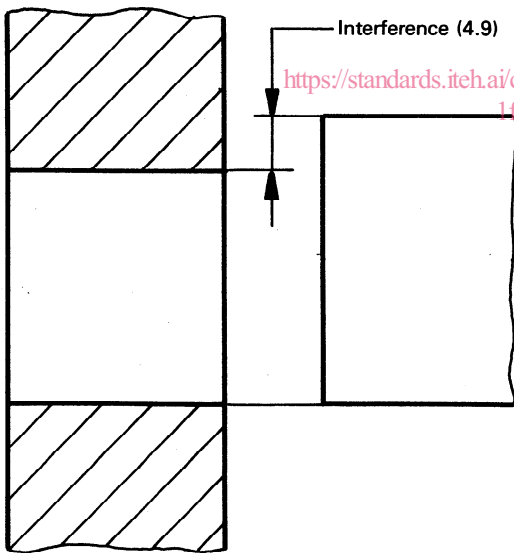

Figure 6 – Interference

4.9.2 maximum interference: In an interference or transition fit, the negative difference, before assembly, between the minimum limit of size of the hole and the maximum limit of size of the shaft (see figures 5 and 7).

4.10 fit: The relationship resulting from the difference, before assembly, between the sizes of the two features (the hole and the shaft) which are to be assembled.

NOTE – The two mating parts of a fit have a common basic size.

4.10.1 clearance fit: A fit that always provides a clearance between the hole and shaft when assembled, i.e. the minimum size of the hole is either greater than or, in the extreme case, equal to the maximum size of the shaft (see figure 8).

ISO 286-1:1988

<https://standards.iteh.ai/catalog/standards/sist/48bb53a9-a9e0-42a6-9400-1fd1e900ce6/iso-286-1-1988>

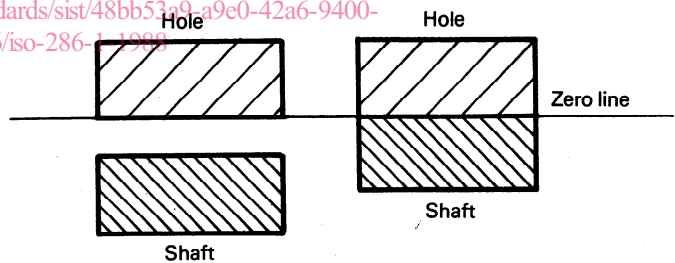

Figure 8 – Schematic representation of clearance fits

4.10.2 interference fit: A fit which everywhere provides an interference between the hole and shaft when assembled, i.e. the maximum size of the hole is either smaller than or, in the extreme case, equal to the minimum size of the shaft (see figure 9).

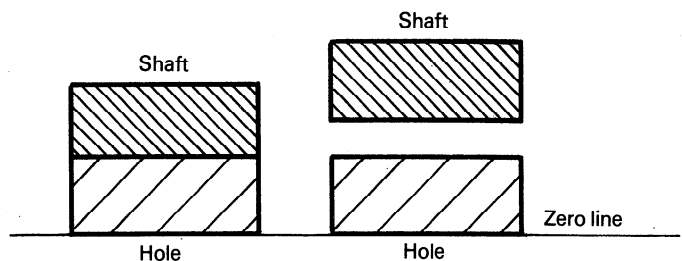

Figure 9 – Schematic representation of interference fits

4.10.3 transition fit: A fit which may provide either a clearance or an interference between the hole and shaft when assembled, depending on the actual sizes of the hole and shaft, i.e. the tolerance zones of the hole and the shaft overlap completely or in part (see figure 10).

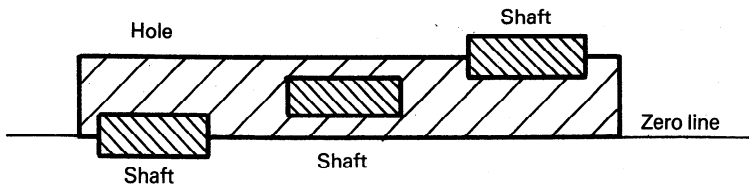

Figure 10 – Schematic representation of transition fits

4.10.4 variation of a fit: The arithmetic sum of the tolerances of the two features comprising the fit.

NOTE – The variation of a fit is an absolute value without sign.

4.11 fit system: A system of fits comprising shafts and holes belonging to a limit system.

4.11.1 shaft-basis system of fits: A system of fits in which the required clearances or interferences are obtained by associating holes of various tolerance classes with shafts of a single tolerance class.

For the purposes of the ISO system of limits and fits, a system of fits in which the maximum limit of size of the shaft is identical to the basic size, i.e. the upper deviation is zero (see figure 11).

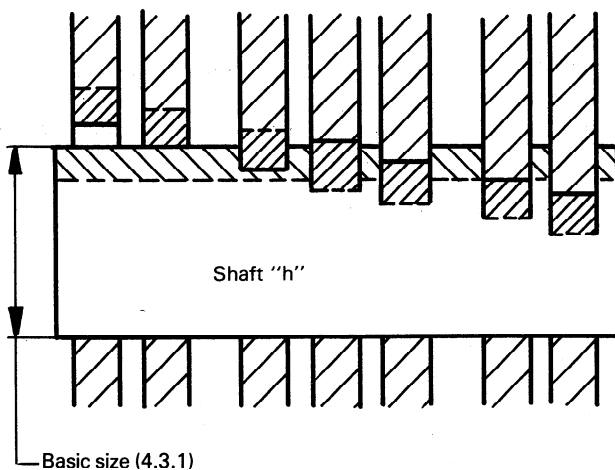

NOTES

- 1 The horizontal continuous lines represent the fundamental deviations for holes or shafts.
- 2 The dashed lines represent the other limits and show the possibility of different combinations between holes and shafts, related to their grade of tolerance (e.g. G7/h4, H6/h4, M5/h4).

Figure 11 – Shaft-basis system of fits

4.11.2 hole-basis system of fits: A system of fits in which the required clearances or interferences are obtained by associating shafts of various tolerance classes with holes of a single tolerance class.

For the purposes of the ISO system of limits and fits, a system of fits in which the minimum limit of size of the hole is identical to the basic size, i.e. the lower deviation is zero (see figure 12).

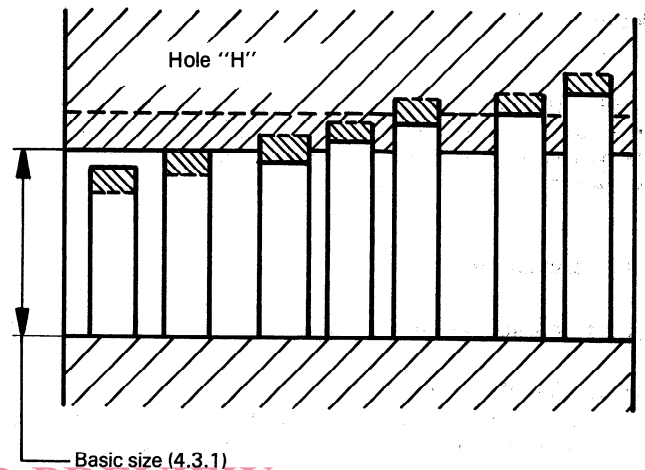

NOTES

- 1 The horizontal continuous lines represent the fundamental deviations for holes or shafts.
- 2 The dashed lines represent the other limits and show the possibility of different combinations between holes and shafts, related to their grade of tolerance (e.g. H6/h6, H6/js5, H6/p4).

Figure 12 – Hole-basis system of fits

4.12 maximum material limit (MML): The designation applied to that of the two limits of size which corresponds to the maximum material size for the feature, i.e.

- the maximum (upper) limit of size for an external feature (shaft),
- the minimum (lower) limit of size for an internal feature (hole).

NOTE – Previously called "GO limit".

4.13 least material limit (LML): The designation applied to that of the two limits of size which corresponds to the minimum material size for the feature, i.e.

- the minimum (lower) limit of size for an external feature (shaft),
- the maximum (upper) limit of size for an internal feature (hole).

NOTE – Previously called "NOT GO limit".

5 Symbols, designation and interpretation of tolerances, deviations and fits

5.1 Symbols

5.1.1 Standard tolerance grades

The standard tolerance grades are designated by the letters IT followed by a number, e.g. IT7. When the tolerance grade is associated with (a) letter(s) representing a fundamental deviation to form a tolerance class, the letters IT are omitted, e.g. h7.

NOTE — The ISO system provides for a total of 20 standard tolerance grades of which grades IT1 to IT18 are in general use and are given in the main body of the standard. Grades IT0 and IT01, which are not in general use, are given in annex A for information purposes.

5.1.2 Deviations

5.1.2.1 Position of tolerance zone

The position of the tolerance zone with respect to the zero line, which is a function of the basic size, is designated by (an) upper case letter(s) for holes (A . . . ZC) or (a) lower case letter(s) for shafts (a . . . zc) (see figures 13 and 14).

NOTE — To avoid confusion, the following letters are not used:

l, i; L, I; O, o; Q, q; W, w.

5.1.2.2 Upper deviations

The upper deviations are designated by the letters "ES" for holes and the letters "es" for shafts.

5.1.2.3 Lower deviations

The lower deviations are designated by the letters "EI" for holes and the letters "ei" for shafts.

5.2 Designation

5.2.1 Tolerance class

A tolerance class shall be designated by the letter(s) representing the fundamental deviation followed by the number representing the standard tolerance grade.

Examples:

H7 (holes)
h7 (shafts)

5.2.2 Toleranced size

A toleranced size shall be designated by the basic size followed by the designation of the required tolerance class, or the explicit deviations.

Examples:

32H7
80js15
100g6
100 $\begin{matrix} -0,012 \\ -0,034 \end{matrix}$

ATTENTION — In order to distinguish between holes and shafts when transmitting information on equipment with limited character sets, such as telex, the designation shall be prefixed by the following letters:

- H or h for holes;
- S or s for shafts.

Examples:

50H5 becomes H50H5 or h50h5
50h6 becomes S50H6 or s50h6

This method of designation shall not be used on drawings.

5.2.3 Fit

A fit requirement between mating features shall be designated by

- a) the common basic size;
- b) the tolerance class symbol for the hole;
- c) the tolerance class symbol for the shaft.

Examples:

52H7/g6 or 52 $\frac{H7}{g6}$

ATTENTION — In order to distinguish between the hole and the shaft when transmitting information on equipment with limited character sets, such as telex, the designation shall be prefixed by the following letters:

- H or h for holes;
- S or s for shafts;
- and the basic size repeated.

Examples:

52H7/g6 becomes H52H7/S52G6 or h52h7/s52g6

This method of designation shall not be used on drawings.

5.3 Interpretation of a toleranced size

5.3.1 Tolerance indication in accordance with ISO 8015

The tolerances for workpieces manufactured to drawings marked with the notation, **Tolerancing ISO 8015**, shall be interpreted as indicated in 5.3.1.1 and 5.3.1.2.

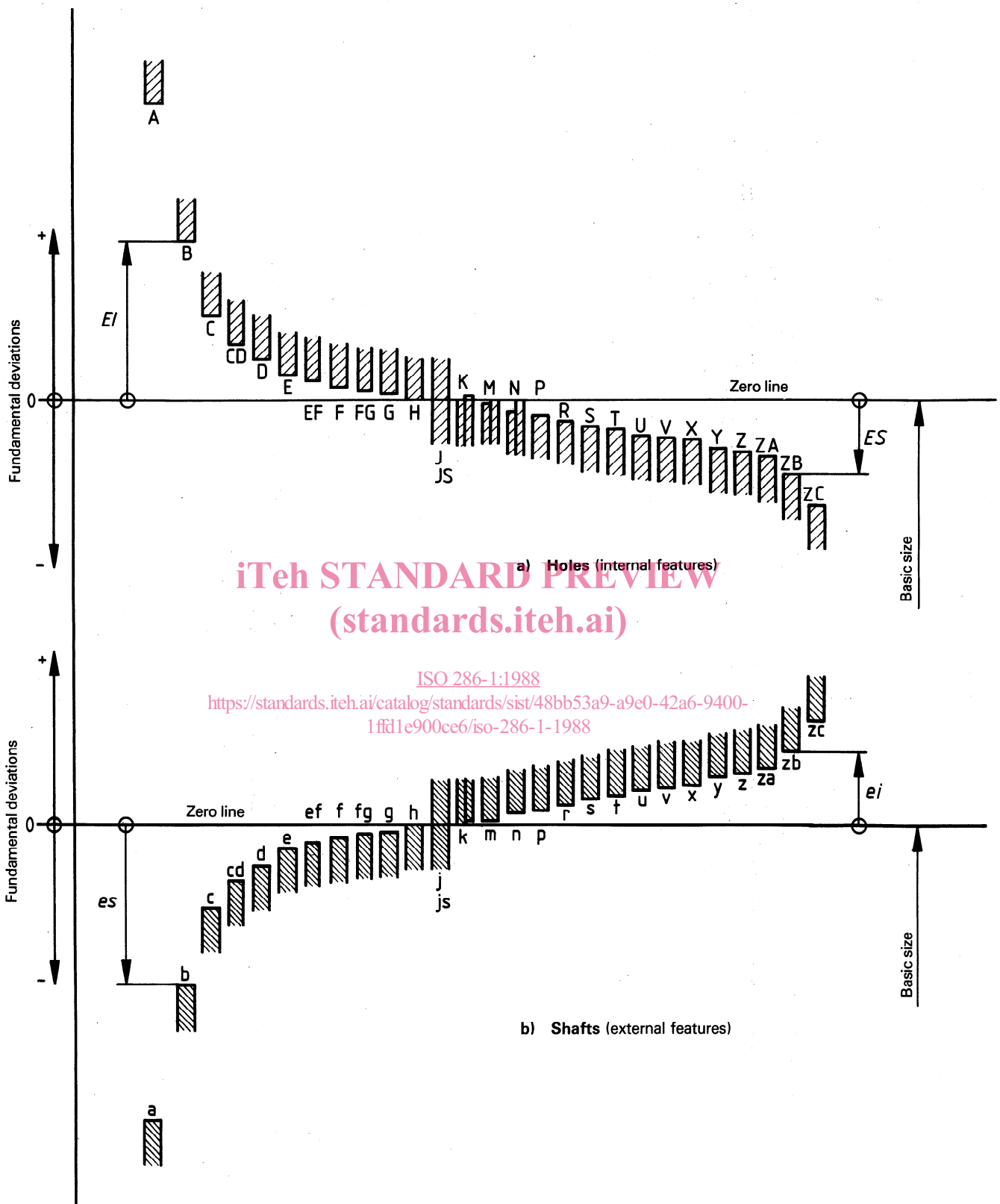

NOTES

- 1 According to convention, the fundamental deviation is the one defining the nearest limit to the zero line.
- 2 For details concerning fundamental deviations for J/j, K/k, M/m and N/n, see figure 14.

Figure 13 — Schematic representation of the positions of fundamental deviations

Deviations

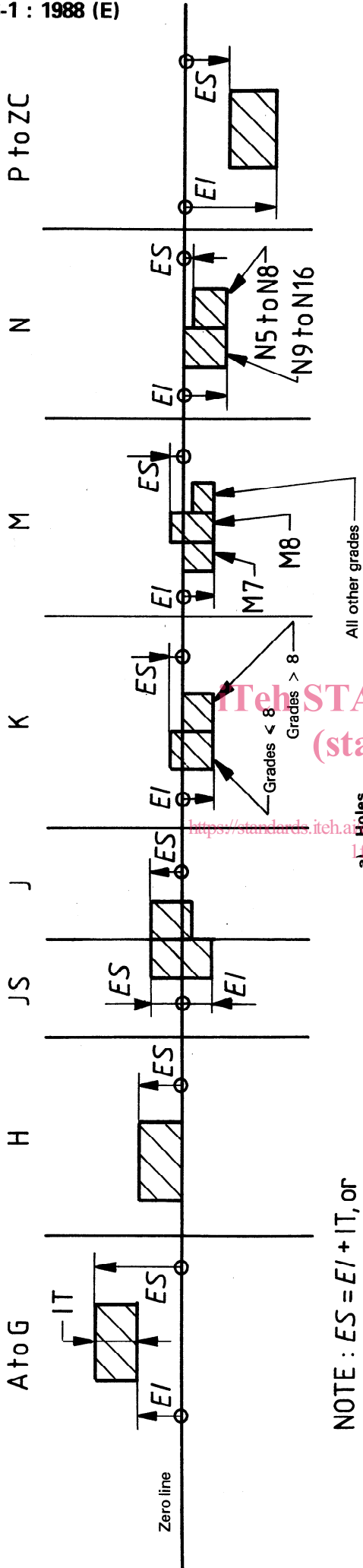

NOTE : $ES = EI + IT$, or
 $EI = ES - IT$

Deviations

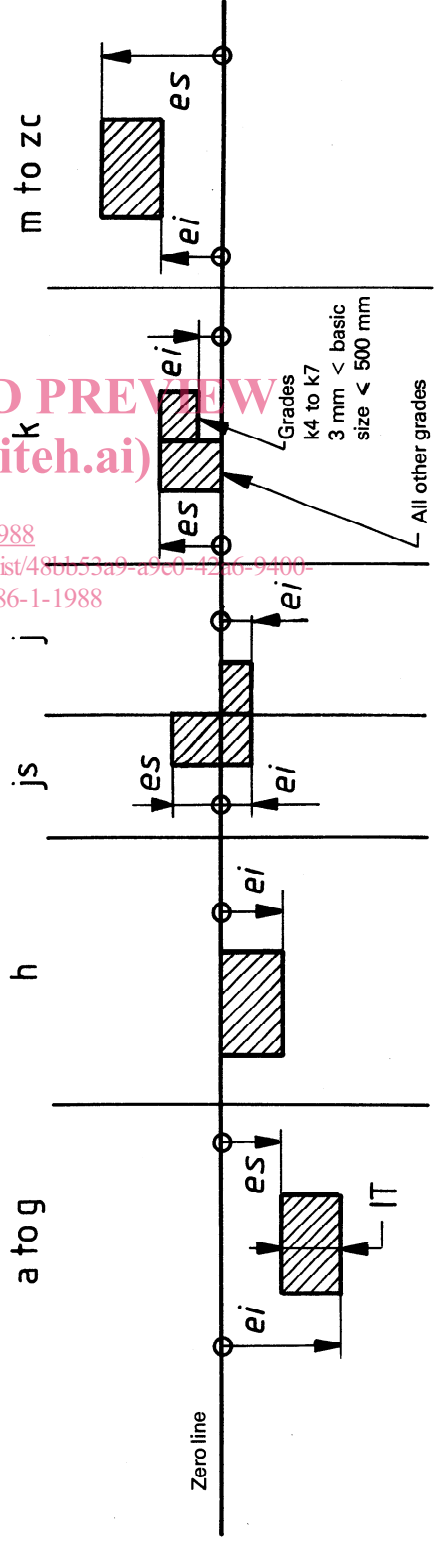

NOTE: $ei = es - IT$, or
 $es = ei + IT$

Figure 14 — Deviations for shafts and holes