Wheelchair seating —

Part 1:

**Vocabulary, reference axis convention
and measures for body segments,
posture and postural support surfaces**

Sièges de fauteuils roulants —

*Partie 1: Vocabulaire, convention des axes de référence et mesures
des segments corporels, des surfaces de posture et du siège*

ISO 16840-1:2006

<https://standards.iteh.ai/catalog/standards/iso/ce164c33-c9cd-49ca-bf67-e8f17855348e/iso-16840-1-2006>



PDF disclaimer

This PDF file may contain embedded typefaces. In accordance with Adobe's licensing policy, this file may be printed or viewed but shall not be edited unless the typefaces which are embedded are licensed to and installed on the computer performing the editing. In downloading this file, parties accept therein the responsibility of not infringing Adobe's licensing policy. The ISO Central Secretariat accepts no liability in this area.

Adobe is a trademark of Adobe Systems Incorporated.

Details of the software products used to create this PDF file can be found in the General Info relative to the file; the PDF-creation parameters were optimized for printing. Every care has been taken to ensure that the file is suitable for use by ISO member bodies. In the unlikely event that a problem relating to it is found, please inform the Central Secretariat at the address given below.

iTeh Standards
(<https://standards.iteh.ai>)
Document Preview

[ISO 16840-1:2006](#)

<https://standards.iteh.ai/catalog/standards/iso/ce164c33-c9cd-49ca-bf67-e8f17855348e/iso-16840-1-2006>

© ISO 2006

The reproduction of the terms and definitions contained in this International Standard is permitted in teaching manuals, instruction booklets, technical publications and journals for strictly educational or implementation purposes. The conditions for such reproduction are: that no modifications are made to the terms and definitions; that such reproduction is not permitted for dictionaries or similar publications offered for sale; and that this International Standard is referenced as the source document.

With the sole exceptions noted above, no other part of this publication may be reproduced or utilized in any form or by any means, electronic or mechanical, including photocopying and microfilm, without permission in writing from either ISO at the address below or ISO's member body in the country of the requester.

ISO copyright office
Case postale 56 • CH-1211 Geneva 20
Tel. + 41 22 749 01 11
Fax + 41 22 749 09 47
E-mail copyright@iso.org
Web www.iso.org

Published in Switzerland

Contents

Page

Foreword.....	iv
Introduction	v
1 Scope	1
2 General terms and definitions	1
3 Abbreviated terms and subscripts.....	6
3.1 Abbreviated terms	6
3.2 Subscripts	6
4 Global coordinate system principles.....	7
4.1 General.....	7
4.2 Structure	7
5 Terms and definitions of an integrated geometric reference system	7
5.1 General.....	7
5.2 Global coordinate system.....	8
5.3 Wheelchair axis system (WAS)	9
5.4 Support surface axis system (SSAS).....	10
5.5 Seated anatomical axis system (SAAS)	11
6 Terms and definitions of support surface measures.....	12
6.1 General.....	12
6.2 Terms and definitions of support surface measures in the sagittal view.....	13
6.3 Terms and definitions of support surface measures in the frontal view	20
6.4 Terms and definitions of support surface measures in the transverse view	26
7 Terms and definitions of body measures of a seated person	30
7.1 General.....	30
7.2 Terms and definitions of body measures in the sagittal plane.....	31
7.3 Terms and definitions of body measures in the frontal view.....	41
7.4 Terms and definitions of body measures in the transverse plane	50
Annex A (normative) Definition of reference lines for common seating support surfaces	56
Annex B (normative) Calculations of joint centres.....	63
Annex C (informative) Abdominal and sternal body segment lines for use in sagittal and frontal body measures.....	68
Bibliography	74
Alphabetical index	75

Foreword

ISO (the International Organization for Standardization) is a worldwide federation of national standards bodies (ISO member bodies). The work of preparing International Standards is normally carried out through ISO technical committees. Each member body interested in a subject for which a technical committee has been established has the right to be represented on that committee. International organizations, governmental and non-governmental, in liaison with ISO, also take part in the work. ISO collaborates closely with the International Electrotechnical Commission (IEC) on all matters of electrotechnical standardization.

International Standards are drafted in accordance with the rules given in the ISO/IEC Directives, Part 2.

The main task of technical committees is to prepare International Standards. Draft International Standards adopted by the technical committees are circulated to the member bodies for voting. Publication as an International Standard requires approval by at least 75 % of the member bodies casting a vote.

Attention is drawn to the possibility that some of the elements of this document may be the subject of patent rights. ISO shall not be held responsible for identifying any or all such patent rights.

ISO 16840-1 was prepared by Technical Committee ISO/TC 173, *Assistive products for persons with disability*, Subcommittee SC 1, *Wheelchairs*.

ISO 16840 consists of the following parts, under the general title *Wheelchair seating*:

- *Part 1: Vocabulary, reference axis convention and measures for body segments, posture and postural support surfaces*
- *Part 2: Determination of physical and mechanical characteristics of devices intended to manage tissue integrity — Seat cushions*
- *Part 3: Determination of static, impact and repetitive load strengths for postural support devices*

The following parts are under preparation:

- *Part 4: Seating systems for use in motor vehicles*
- *Part 5: Determination of pressure relief characteristics of seat cushions intended to manage tissue integrity*

Introduction

The development of wheelchair seating as a sub-specialty of rehabilitation services has been occurring over the last several decades. This practice involves the selection and provision of wheelchair seating products that provide improved body support, movement control, and injury prevention for the wheelchair user. Inherent in this selection process is the measurement and communication of the anthropometrics and postural measures of the seated person, as well as the orientation, location and linear measures of the person's seating support surfaces.

However, there has been tremendous variation in the use of the terminology and definitions related to the clinical measures of a seated individual. Standard definitions and terms are lacking for communicating critical postural information and support surface parameters in a way that is uniformly useful to service providers, researchers, manufacturers, wheelchair users and purchasers when selecting and providing wheelchair seating devices.

The purpose of this part of 16840 is to specify standardised geometric terms and definitions for describing and quantifying a person's anthropometric measures and seated posture, as well as the spatial orientation and dimensions of a person's seating support surfaces. This also allows for the systematic monitoring of a person's seated posture change over time.

iTeh Standards (<https://standards.iteh.ai>) Document Preview

[ISO 16840-1:2006](https://standards.iteh.ai/catalog/standards/iso/ce164c33-c9cd-49ca-bf67-e8f17855348e/iso-16840-1-2006)

<https://standards.iteh.ai/catalog/standards/iso/ce164c33-c9cd-49ca-bf67-e8f17855348e/iso-16840-1-2006>

Wheelchair seating —

Part 1:

Vocabulary, reference axis convention and measures for body segments, posture and postural support surfaces

1 Scope

This part of ISO 16840 applies to seating intended to provide postural support within a wheelchair. It specifies:

- a) a global coordinate system that permits the determination and recording of a person's posture while seated in a wheelchair;
- b) the standard terms and definitions for use in describing both the posture and the anthropometrics of a person seated in a wheelchair;
- c) the terms and definitions for describing the dimensions, location and orientation of seating support surfaces, which together comprise the body support system.

This part of ISO 16840 does not specify any methods for use in measuring a person's seated posture, nor does it define terms for dynamic physiological movements (such as flexion or extension).

This part of 16840 might be applicable to seating other than that intended to be used within a wheelchair.

2 General terms and definitions

2.1

absolute angle

angle which represents the orientation in space of a body segment or support surface reference plane relative to the gravitational axis system

NOTE See 5.2.

2.2

body centreline

vertical line falling on the midsagittal plane of the body, as viewed in the frontal plane

2.3

body segment line

line defined by two designated body landmarks, either palpated or calculated, used in determining angular positions of body segments

2.4

contact surface

surface of the seating support in contact with the seated person's body

2.5
depth

linear dimension of a seating support surface measured in the Y direction on a line parallel to the support surface reference plane

See Figure 1.

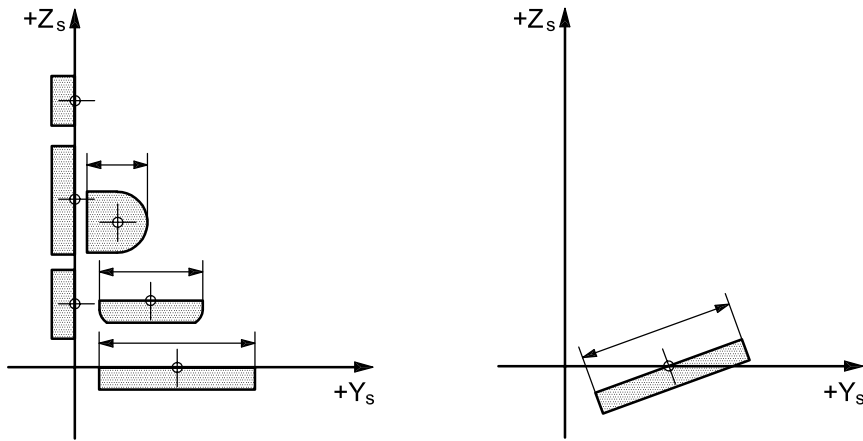

Figure 1 — Examples of depth

2.6
length

linear dimension of a seating support surface measured in the Z direction on a line parallel to the support surface reference plane

See Figure 2.

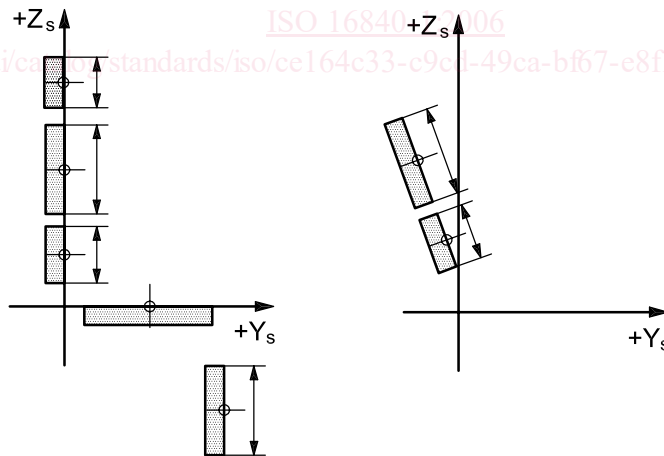

Figure 2 — Examples of length

2.7
reference position

fixed hypothetical baseline position to which other positions may be referenced

2.8
relative angle

angle formed between two body segment lines or two support surface reference lines

2.9**seated anatomical axis system****SAAS**

axis system used to define the orientation of the body segments in space and to each other

2.10**seated reference position****SRP**

orthogonal seated position to which other positions may be referenced

2.11**support surface axis system****SSAS**

axis system used to define the orientation, location and linear dimensions of seating support surfaces

2.12**support surface geometric centre****SSGC**

point of intersection of two or more lines joining the furthest points from the edges of a contact surface, measured along the surface

See Figure 3.

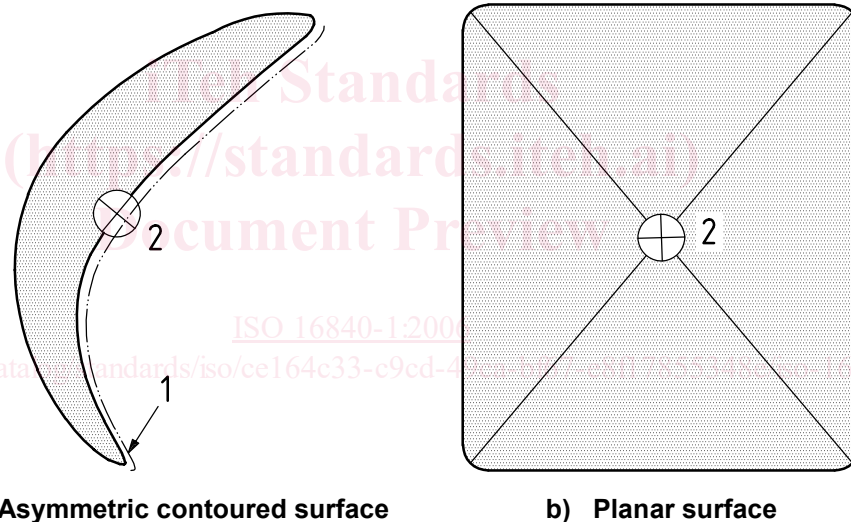
**Key**

- 1 line along the contoured surface
- 2 support surface geometric centre (SSGC)

Figure 3 — Illustration of the SSGC on curved and planar support surfaces

2.13**support surface reference line**

designated line passing through the support surface geometric centre used in measurement of the absolute and relative angles of the seating support surface

2.14**support surface reference position****SSRP**

fixed hypothetical baseline position of support surfaces in the three orthogonal planes to which other positions may be referenced

2.15 support surface reference plane

plane passing through the SSGC tangential to the surface curvature at the SSGC radius at the point of the SSGC

See Figure 4.

NOTE The tangent to the radius of a planar surface is parallel to the surface.

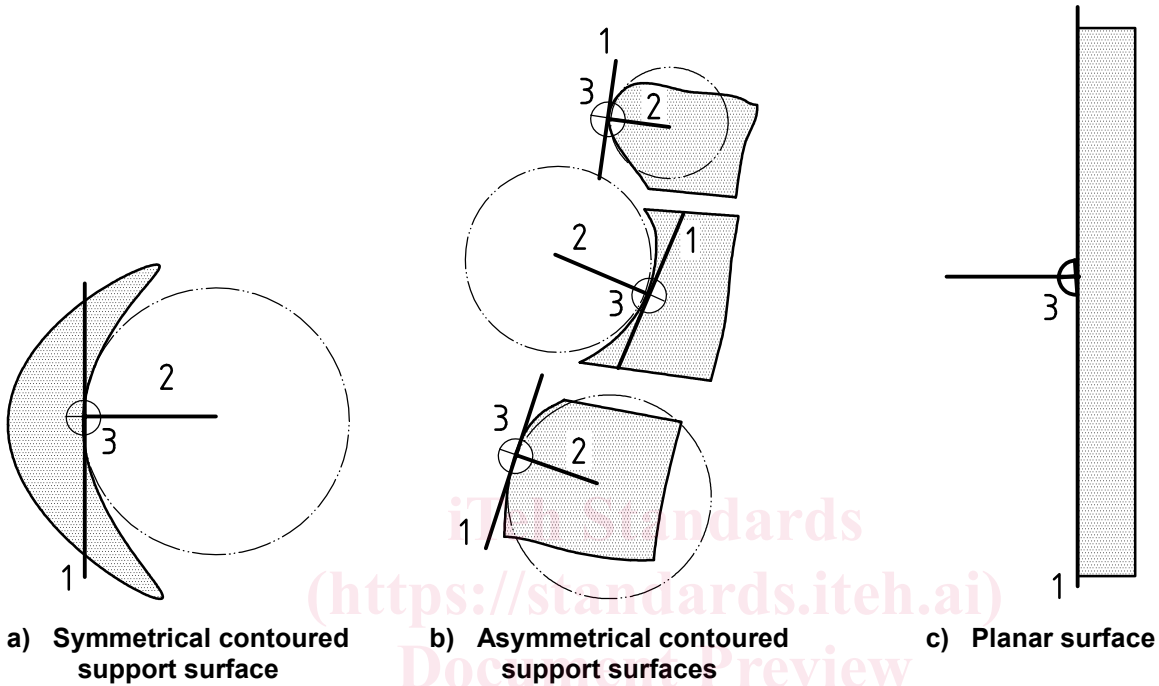

Key

- 1 support surface reference plane
- 2 radius of the support surface curve at the SSGC
- 3 SSGC

Figure 4 — Examples of support surface reference planes for contoured and planar surfaces

2.16**thickness**

linear dimension of a seating support surface measured perpendicular to the support surface reference plane

See Figure 5.

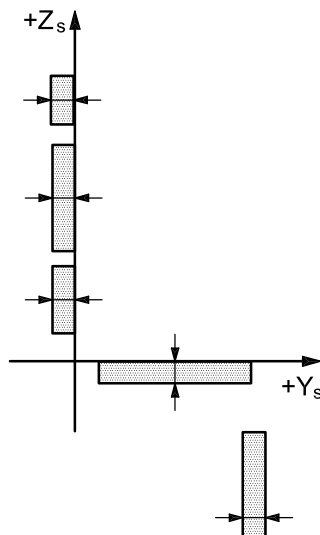

Figure 5 — Examples of thickness

2.17**wheelchair axis system****WAS**

axis system which may be used to define the orientation and location of the person and any items attached to or contained within a wheelchair base relative to that base

2.18**width**

linear dimension of a seating support surface measured in the X direction on a line parallel to the support surface reference plane

See Figure 6.

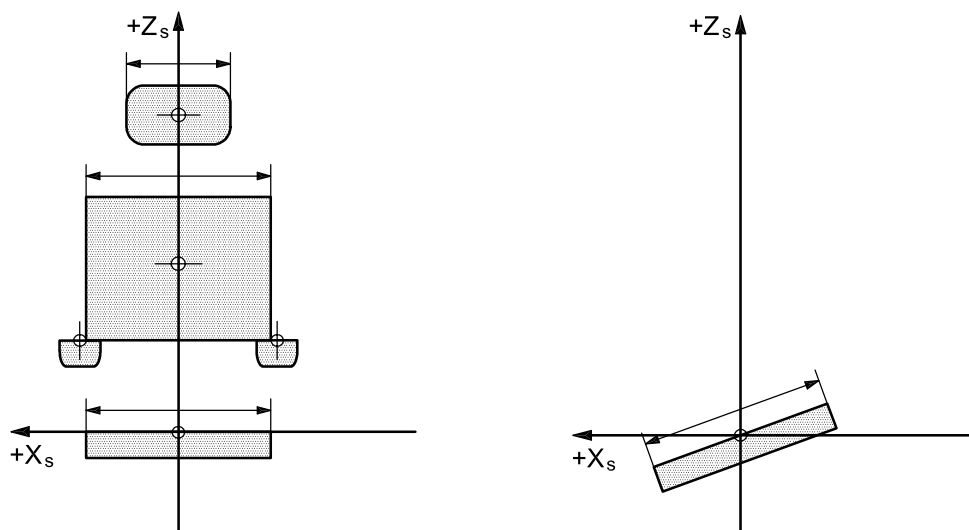

Figure 6 — Examples of width

3 Abbreviated terms and subscripts

3.1 Abbreviated terms

AS	anterior support
ASIS	anterior superior iliac spine
IS	inferior support
LS	lateral support
MS	medial support
PS	posterior support
PSIS	posterior superior iliac spine
SAAS	seated anatomical axis system
SSAS	support surface axis system
SRP	seated reference position
SSGC	support surface geometric centre
SSRP	support surface reference position
WAS	wheelchair axis system

3.2 Subscripts

d	depth
ed	effective depth
el	effective length
ew	effective width
fang	frontal angle
floc	frontal location
L	left
l	length
R	right
sang	sagittal angle
sloc	sagittal location
t	thickness
tang	transverse angle
tloc	transverse location
w	width

iteh Standards
(<https://standards.iteh.ai>)
Document Preview

[ISO 16840-1:2006](https://standards.iteh.ai/catalog/standards/iso/ce164c33-c9cd-49ca-bf67-e8f17855348e/iso-16840-1-2006)

<https://standards.iteh.ai/catalog/standards/iso/ce164c33-c9cd-49ca-bf67-e8f17855348e/iso-16840-1-2006>

4 Global coordinate system principles

4.1 General

This part of 16840 is based on a three-dimensional global coordinate system applied separately to the wheelchair, the seating support surfaces and the wheelchair user. Separately and/or collectively this coordinate system allows for measurement in the three traditional orthogonal planes of locations, linear measures, and angles of the body segments of a person and the seating support surfaces.

The measures of a person (either linear or angular) will not necessarily be identical to those of the seating support surfaces. The prescription of a seating support surface should be determined through clinical interpretation or translation of the measures of a person into those appropriate for support surfaces that will adequately support a person in a desired posture.

4.2 Structure

Clause 5 specifies the integrated geometric reference system upon which all the following definitions for this part of ISO 16840 are based. Next, the measurement definitions for seating support surfaces, and the body measures are specified. They are each defined using the three orthogonal planes, sagittal, frontal and transverse. For each plane, a standard reference position (SSRP or SRP), and definitions for measures of support surface locations, linear dimensions, absolute angles and relative angles (where appropriate) are specified.

5 Terms and definitions of an integrated geometric reference system

5.1 General

The following are terms and definitions for an integrated geometric reference system that permits the measurement of a person's seated posture. The measured seated posture can then be recorded relative to the person's seating support surfaces, and finally, in relation to the global reference (the wheelchair frame) in which the person is seated.

Five interrelated components comprise the integrated geometric reference system:

- a) the wheelchair axis system (WAS) defines a fixed global reference system, specified by the geometry of each person's wheelchair after configuration of that wheelchair for the specific person;
- b) the support surface axis system (SSAS) defines the coordinate conventions used to specify the support surface reference position;
- c) the support surface reference position (SSRP) defines a fixed hypothetical position of the support surfaces to which other positions may be referenced;
- d) the seated anatomical axis system (SAAS) defines the geometric measures used to specify and record the positions of a person's body segments relative to the seated reference position;
- e) the seated reference position (SRP) defines a fixed hypothetical position of the seated person to which other positions may be referenced.

The integration and application of these interrelated geometric systems allow the systematic measurement and recording of a person's wheelchair-seated posture. Subsequent measurements will allow the systematic monitoring of seated posture change over time.

Of fundamental importance are the selection and consistent use of an axis system. This convention, termed the global coordinate system, then allows the systematic integration of the above measurements.

For all measurements, when a line or coordinate position does not fall on one of the three defined orthogonal planes, the line or coordinate position is projected to the appropriate plane and then measurements are taken.

NOTE This simplification reduces all three-dimensional measures to two measurements, which is consistent with current clinical practice.

5.2 Global coordinate system

5.2.1 Basis

The global coordinate system is based on a gravitational axis system in which the +Z axis has been designated as the upward vertical axis. Both X and Y axes are at right angles to Z and to each other. The location of the origin for the global coordinate system is described in 5.3.

5.2.2 Direction of axes

The right-hand directional rule is used to define the directions of the coordinate axes, specifically, thumb vertical along the positive (+) Z axis, index finger defines the positive (+) X axis, and the middle finger defines the positive (+) Y axis

See Figure 7.

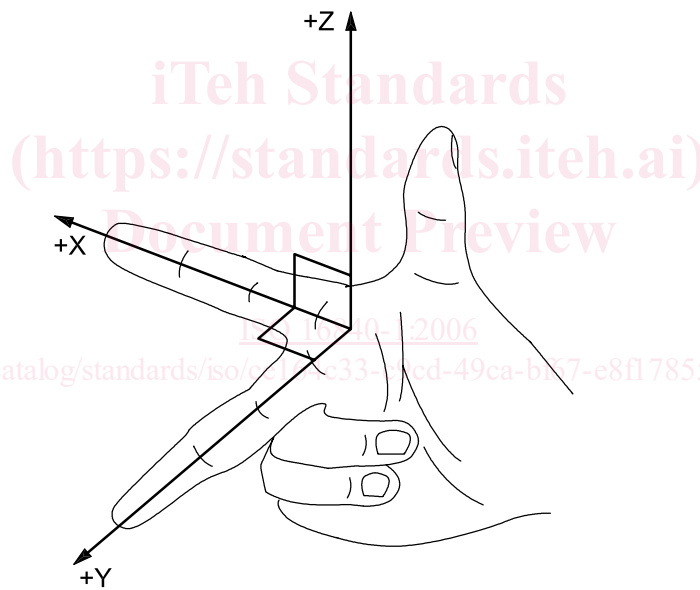

Figure 7 — Right-hand directional rule defines positive directions of axes X, Y and Z