**Fluid power systems — O-rings —
Part 4:
Anti-extrusion rings (back-up rings)**

*Transmissions hydrauliques et pneumatiques — Joints toriques —
Partie 4: Bagues anti-extrusion*

**iTeh STANDARD PREVIEW
(standards.iteh.ai)**

[ISO 3601-4:2008](https://standards.iteh.ai/catalog/standards/sist/ccbf4d2e-a8ea-4ef1-85b1-5b997d09de2a/iso-3601-4-2008)

<https://standards.iteh.ai/catalog/standards/sist/ccbf4d2e-a8ea-4ef1-85b1-5b997d09de2a/iso-3601-4-2008>



PDF disclaimer

This PDF file may contain embedded typefaces. In accordance with Adobe's licensing policy, this file may be printed or viewed but shall not be edited unless the typefaces which are embedded are licensed to and installed on the computer performing the editing. In downloading this file, parties accept therein the responsibility of not infringing Adobe's licensing policy. The ISO Central Secretariat accepts no liability in this area.

Adobe is a trademark of Adobe Systems Incorporated.

Details of the software products used to create this PDF file can be found in the General Info relative to the file; the PDF-creation parameters were optimized for printing. Every care has been taken to ensure that the file is suitable for use by ISO member bodies. In the unlikely event that a problem relating to it is found, please inform the Central Secretariat at the address given below.

iTeh STANDARD PREVIEW
(standards.iteh.ai)

ISO 3601-4:2008

<https://standards.iteh.ai/catalog/standards/sist/ccbf4d2e-a8ea-4ef1-85b1-5b997d09de2a/iso-3601-4-2008>



COPYRIGHT PROTECTED DOCUMENT

© ISO 2008

All rights reserved. Unless otherwise specified, no part of this publication may be reproduced or utilized in any form or by any means, electronic or mechanical, including photocopying and microfilm, without permission in writing from either ISO at the address below or ISO's member body in the country of the requester.

ISO copyright office
Case postale 56 • CH-1211 Geneva 20
Tel. + 41 22 749 01 11
Fax + 41 22 749 09 47
E-mail copyright@iso.org
Web www.iso.org

Published in Switzerland

Contents

Page

Foreword.....	iv
Introduction	v
1 Scope	1
2 Normative references	1
3 Terms and definitions	1
4 Symbols	2
5 General requirements related to O-ring housings	2
6 Types of anti-extrusion (back-up) rings	3
6.1 Spiral type, T1	3
6.2 Angle cut type, T2	5
6.3 Solid type, T3	5
6.4 Angle cut concave type, T4	6
6.5 Solid concave type, T5	7
7 Positioning of anti-extrusion rings in housings	8
8 Anti-extrusion ring designation code and materials	8
8.1 Designation code	8
8.2 Materials	9
9 Dimensions and tolerances	9
9.1 Axial and radial widths of anti-extrusion rings	9
9.2 Outside diameters of anti-extrusion rings for piston sealing applications	10
9.3 Inside diameters of anti-extrusion rings for rod sealing applications	11
10 Identification statement (reference to this part of ISO 3601)	11

Foreword

ISO (the International Organization for Standardization) is a worldwide federation of national standards bodies (ISO member bodies). The work of preparing International Standards is normally carried out through ISO technical committees. Each member body interested in a subject for which a technical committee has been established has the right to be represented on that committee. International organizations, governmental and non-governmental, in liaison with ISO, also take part in the work. ISO collaborates closely with the International Electrotechnical Commission (IEC) on all matters of electrotechnical standardization.

International Standards are drafted in accordance with the rules given in the ISO/IEC Directives, Part 2.

The main task of technical committees is to prepare International Standards. Draft International Standards adopted by the technical committees are circulated to the member bodies for voting. Publication as an International Standard requires approval by at least 75 % of the member bodies casting a vote.

Attention is drawn to the possibility that some of the elements of this document may be the subject of patent rights. ISO shall not be held responsible for identifying any or all such patent rights.

ISO 3601-4 was prepared by Technical Committee ISO/TC 131, *Fluid power systems*, Subcommittee SC 7, *Sealing devices*.

ISO 3601 consists of the following parts, under the general title *Fluid power systems — O-rings*:

- *Part 1: Inside diameters, cross-sections, tolerances and designation codes*
- *Part 2: Housing dimensions for general applications*
- *Part 3: Quality acceptance criteria*
- *Part 4: Anti-extrusion rings (back-up rings)*
- *Part 5: Suitability of elastomeric materials for industrial applications*

iTeh STANDARD PREVIEW
(standards.iteh.ai)

ISO 3601-4:2008
<https://standards.iteh.ai/catalog/standards/sist/ccbf4d2e-a8ea-4ef1-85b1-5b997d09de2a/iso-3601-4-2008>

Introduction

In fluid power systems, power is transmitted and controlled through a fluid (liquid or gas) under pressure within an enclosed circuit. Where high pressures are encountered, it is recommended that an anti-extrusion ring (back-up ring) be incorporated within the O-ring housing to limit extrusion of the O-ring between the metal parts (e.g. cylinder bore and piston or rod and housing).

iTeh STANDARD PREVIEW (standards.iteh.ai)

[ISO 3601-4:2008](https://standards.iteh.ai/catalog/standards/sist/ccbf4d2e-a8ea-4ef1-85b1-5b997d09de2a/iso-3601-4-2008)

<https://standards.iteh.ai/catalog/standards/sist/ccbf4d2e-a8ea-4ef1-85b1-5b997d09de2a/iso-3601-4-2008>

iTeh STANDARD PREVIEW
(standards.iteh.ai)

ISO 3601-4:2008

<https://standards.iteh.ai/catalog/standards/sist/ccbf4d2e-a8ea-4ef1-85b1-5b997d09de2a/iso-3601-4-2008>

Fluid power systems — O-rings —

Part 4: Anti-extrusion rings (back-up rings)

1 Scope

This part of ISO 3601 specifies dimensions and tolerances for five types of anti-extrusion rings, which are also known as back-up rings:

- a) spiral type (T1);
- b) angle cut type (T2);
- c) solid type (T3);
- d) angle cut concave type (T4);
- e) solid concave type (T5).

These anti-extrusion rings are for use with selected O-ring sizes as specified in ISO 3601-1 and the relevant housing dimensions specified in ISO 3601-2.

2 Normative references

The following referenced documents are indispensable for the application of this document. For dated references, only the edition cited applies. For undated references, the latest edition of the referenced document (including any amendments) applies.

ISO 3601-1¹⁾, *Fluid power systems — O-rings — Part 1: Inside diameters, cross-sections, tolerances and designation codes*

ISO 3601-2:2008, *Fluid power systems — O-rings — Part 2: Housing dimensions for general applications*

ISO 5598, *Fluid power systems and components — Vocabulary*

3 Terms and definitions

For the purposes of this document, the terms and definitions given in ISO 5598 apply.

1) To be published. (Revision of ISO 3601-1:2002)

4 Symbols

The following letter symbols are used in this part of ISO 3601:

b_1	width of O-ring housing without anti-extrusion ring
b_2	width of O-ring housing with one anti-extrusion ring
b_3	width of O-ring housing with two anti-extrusion rings
b_5	width of single anti-extrusion ring, angle cut types T2 and T4, and solid types T3 and T5
b_6	width of anti-extrusion ring, spiral type T1
b_7	total width ($b_5 + h$) at apex of single anti-extrusion ring, angle cut concave type T4 and solid concave type T5
d_2	O-ring cross-section diameter
d_3	housing diameter for piston seal housings
d_4	bore diameter for piston application
d_5	rod diameter
d_6	housing diameter for rod seal housings
d_9	piston diameter
d_{10}	bore diameter for rod application
d_{14}	internal diameter of anti-extrusion ring (spiral type T1 only)
d_{15}	external diameter of anti-extrusion ring (spiral type T1 only)
d_{16}	inside diameter of anti-extrusion ring (angle cut types T2 and T4, or solid types T3 and T5)
d_{17}	outside diameter of anti-extrusion ring (angle cut types T2 and T4, or solid types T3 and T5)
h	extension of concave anti-extrusion ring beyond b_5 base width
l	gap of anti-extrusion ring, spiral type T1, on mandrel diameter d_{14}
R	radius of cavity in concave anti-extrusion ring
t	radial section of anti-extrusion ring

5 General requirements related to O-ring housings

For general requirements of O-ring housings, such as surface roughness, corners and edges of undefined shape, lead-in chamfers, housing diameter tolerances and housing widths, see the related clauses in ISO 3601-2.

6 Types of anti-extrusion (back-up) rings

6.1 Spiral type, T1

6.1.1 The spiral type, T1, anti-extrusion ring (see Figure 1) is typically associated with applications in which the system pressure is between 10 MPa (100 bar) and 20 MPa (200 bar). Continuous rings, such as the angle cut type (T2) or the solid type (T3), are preferred for use at pressures higher than 20 MPa (200 bar), but assembly problems can be encountered with closed housings or at small diameters.

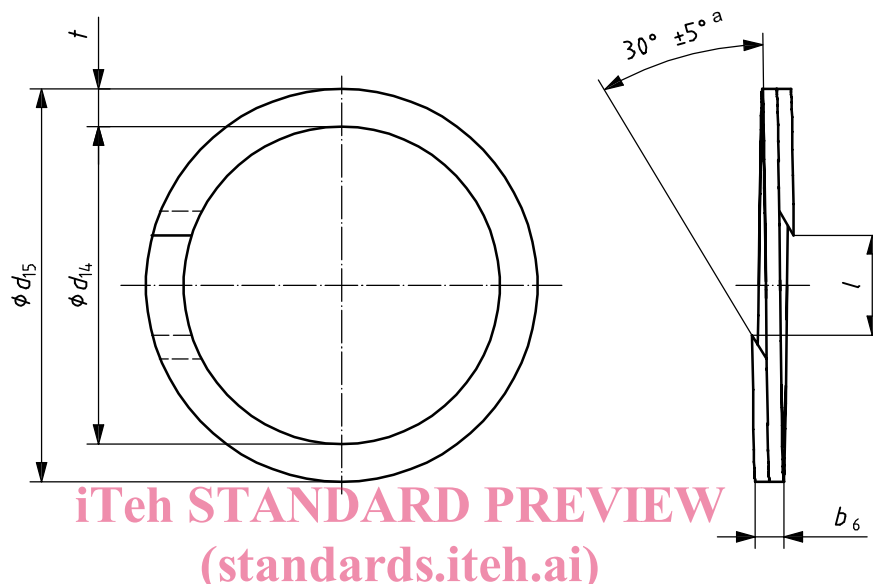

^a This angle may be increased to $45^\circ \pm 5^\circ$ when d_{14} is less than 7,0 mm.

NOTE Direction of the spiral is optional. [ISO 3601-4:2008](https://standards.iteh.ai/catalog/standards/sist/ccbf4d2e-a8ea-4ef1-85b1-3b97e2dca790/iso-3601-4-2008)

<https://standards.iteh.ai/catalog/standards/sist/ccbf4d2e-a8ea-4ef1-85b1-3b97e2dca790/iso-3601-4-2008>

Figure 1 — Spiral type (T1) anti-extrusion ring

6.1.2 At higher temperatures, typically in excess of 100 °C, anti-extrusion rings can be necessary even when pressures are less than 10 MPa (100 bar). Independent of temperature and pressure, special operating conditions can also require the use of anti-extrusion rings. These operating conditions should be discussed with the seal supplier at the design stage.