



Designation: D 2797 – 85 (Reapproved 1999)

Standard Practice for Preparing Coal Samples for Microscopical Analysis by Reflected Light¹

This standard is issued under the fixed designation D 2797; the number immediately following the designation indicates the year of original adoption or, in the case of revision, the year of last revision. A number in parentheses indicates the year of last reapproval. A superscript epsilon (ϵ) indicates an editorial change since the last revision or reapproval.

1. Scope

1.1 This practice covers laboratory procedures for the preparation of granular samples of bituminous coal and anthracite samples for examination with a microscope using reflected light illumination. It does not apply to the preparation of oriented blocks of coal.

1.2 The values stated in SI units shall be considered as standard; and inch-pound units shall be considered as approximate equivalents.

1.3 *This standard does not purport to address the safety concerns associated with its use. It is the responsibility of the user of this standard to establish appropriate safety and health practices and determine the applicability of regulatory limitations prior to use.*

2. Referenced Documents

2.1 ASTM Standards:

- D 2013 Method of Preparing Coal Samples for Analysis²
- D 2234 Test Methods for Collection of a Gross Sample of Coal²
- D 2798 Test Method for Microscopical Determination of the Reflectance of Vitrinite in a Polished Specimen of Coal²
- D 2799 Test Method for Microscopical Determination of Volume Percent of Physical Components of Coal²
- D 4596 Practice for Collection of Channel Samples of Coal in the Mine²
- E 11 Specification for Wire-Cloth Sieves for Testing Purposes³

3. Summary of Practice

3.1 A representative sample is crushed to a specified particle size, air-dried, mixed with a binder, and formed into a briquet. The briquet is then polished to a flat, scratch-free surface for examination by vertical illumination.

¹ This practice is under the jurisdiction of ASTM Committee D-5 on Coal and Coke and is the direct responsibility of Subcommittee D05.28 on Petrographic Analysis of Coal and Coke.

Current edition approved Aug. 30, 1985. Published October 1985. Originally published as D 2797 – 69 T. Last previous edition D 2797 – 85.

² *Annual Book of ASTM Standards*, Vol 05.06.

³ *Annual Book of ASTM Standards*, Vol 14.02.

4. Significance and Use

4.1 Briquets of granular bituminous coals and anthracite prepared in accordance with the laboratory procedures of this practice will have flat, scratch-free surfaces suitable for examination with a microscope using reflected light illumination. The polished surfaces of briquettes prepared by this practice will contain particles representative of the original gross sample.

4.2 Samples prepared by this practice are used for microscopical determination of the reflectance of the organic components in a polished specimen of coal (Test Method D 2798) and for microscopical determination of the volume percent of physical components of coal (Test Method D 2799).

5. Apparatus

5.1 *Grinder, Pulverizer, or Mill*, for final crushing of the sample to pass a 850- μ m (No. 20) sieve. Mortar and pestle or other equipment suitable for reducing the particle size of a 250-g sample that already passes a 4.75-mm (No. 4) sieve until all of it passes a 850- μ m (No. 20) sieve (see 6.5).

5.2 *Coarse Riffle Sampler*—a riffle with at least twelve divisions of not less than 12.7 mm ($\frac{1}{2}$ in.) and not greater than 19.1 mm ($\frac{3}{4}$ in.).

5.3 *Fine Riffle Sampler*⁴—a riffle with at least twelve divisions of not less than 3.2 mm ($\frac{1}{8}$ in.) and not greater than 6.4 mm ($\frac{1}{4}$ in.).

5.4 *Sieves*—a 4.75-mm (No. 4) and a 850- μ m (No. 20) U.S. Standard Sieve (Specification E 11).

5.5 *Molds*—containers to hold the coal binder mixture while the binder hardens.

5.5.1 The mold shall be capable of withstanding pressures up to 70 MPa (10 000 psi), and shall be made of separable parts so that the briquet can be ejected after it has hardened.

5.5.2 The mold shall be large enough to provide a plane area of 4 cm² or more on one side of the briquet. (Designs of suitable 25-mm (1-in.) and 32-mm (1¼-in.) inside-diameter molds are shown in Fig. 1).

5.6 *Hydraulic Press*—a press that is capable of producing a pressure up to 35 MPa (5000 psi) on the briquet, and has an attachment to eject the briquet after solidification of the binder.

⁴ A suitable riffle sampler is made by Sepor Laboratory, PO Box 736, Ottawa, IL.

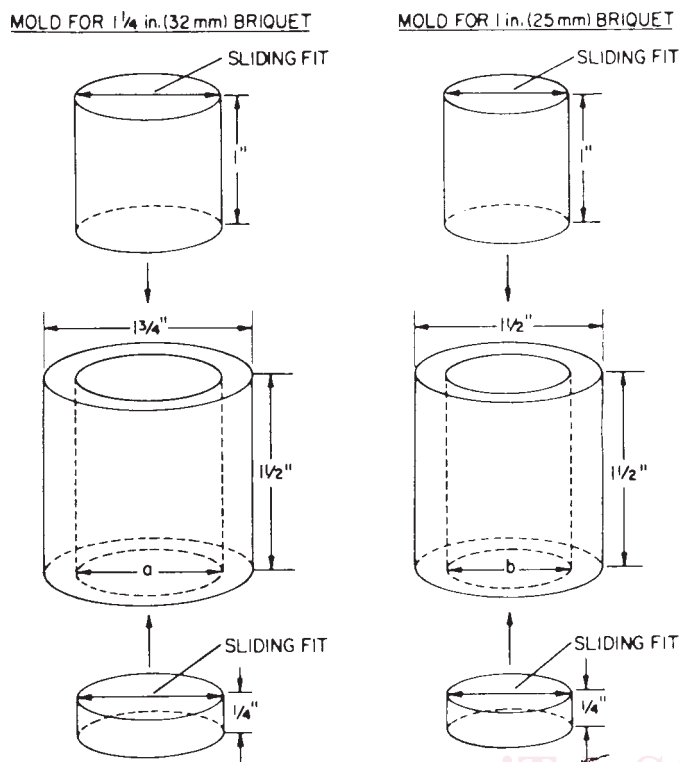

NOTE 1—Material: cold rolled or stainless steel. Dimensions *a* and *b* (inside diameters) are nominally 32 mm (1 1/4 in.) and 25 mm (1 in.). If an automatic polishing attachment is to be used, these dimensions should be specified to yield a briquet fitting snugly in the briquet holder.

FIG. 1 Molds Suitable for Briquetting Coal Samples

5.7 *Grinding and Polishing Equipment*—one or several laps on which the coal briquet can be ground and polished to a flat, scratch-free surface. Laps may be made of aluminum, iron, brass, bronze, lead, glass, wax, or wood. For notes on grinding and polishing practices, see Appendix X1.

NOTE 1—Equipment that has 203-mm (8-in.) diameter disk laps, gear-driven at 160 to 170 r/min, and that has an automatic sample holder attachment is recommended.⁵

5.8 *Sample Cleaner*—some equipment is essential for cleaning coal briquets between the different grinding or polishing stages. This may be a simple stream of water or an air jet, but an ultrasonic cleaner is recommended.

5.9 *Containers*—if samples are to be transported or stored before briquets are prepared, glass jars, bottles, or metal cans having tight-fitting closures shall be used. Metal cans shall have plastic liners.

6. Materials

6.1 *Binder*—Any binding material fulfilling the following requirements may be used for preparing the coal briquet:

6.1.1 The binder shall hold all coal particles securely during grinding, polishing, and observing the sample.

6.1.2 The binder shall not react with the coal or the atmosphere or expose the coal sample to a temperature above 100°C.

6.1.3 Under the microscope, the binder shall contrast markedly with constituents being measured when immersed in oil having an index of refraction of about 1.518.

6.1.4 The binder shall be such that a substantially flat and scratch-free surface can be obtained as a result of the grinding and polishing procedure.

NOTE 2—Relief, or difference in level, particularly between the coal and the binder, is undesirable for reflectance determination. Although relief depends a great extent on the polishing technique, use of a binder with a hardness comparable to that of the coal is very helpful.

NOTE 3—An epoxy resin⁶ has been found suitable. The resin is composed of the diglycidyl ethers of bis-phenol-A and its homologs and is diluted with butyl glycidyl ether. The resin is used with an activator composed of aliphatic polyamines or their adducts or both. The amount of activator is calculated from the equation:

$$A = 100 M_A/EH \quad (1)$$

where:

A = amount of activator, parts per 100 (by weight) of resin diluent mixture;

M_A = molecular weight of activator;

E = epoxide equivalent weight of epoxy-diluent mixture; and

H = number of active hydrogens per molecular of activator.

6.2 *Release Agent*—Any preparation that does not damage the molds or adversely affect the coal or mounting medium may be used to coat the inside of the mold and facilitate ejection of the briquet.⁷

6.3 *Grinding Abrasives*—Water-resistant, adhesive-backed silicon carbide papers of grit Nos. 240, 320, 400, and 600. Two or three of these are used according to a plan such as one of those listed in Table 1.^{293fb79d7/astm-d2797-851999}

6.4 *Polishing Abrasives*—Aluminum oxide powders of 3-, 1-, 0.3-, 0.1-, and 0.05-μm sizes. Two or three of these are used according to a plan such as one of those listed in Table 1.

6.5 *Lap Coverings*—Nap-free cloths of cotton and silk, and chemotextile material backed with water-resistant adhesive.⁸

6.6 *Detergent*—Any nonoxidizing detergent may be used for cleaning briquets after each grinding or polishing stage.

7. Sampling

7.1 Obtain samples (Note 4) of coal in accordance with Test Methods D 2234 and Practice D 4596, when appropriate.

7.2 If the coal sample has not previously been air dried, bring the sample to room conditions by exposure to the laboratory atmosphere.

⁵ Buehler, Lt., 2120 Greenwood St., Evanston, IL, and Geoscience Instruments Corp., 110 Beckman St., New York, NY, supply grinding and polishing machines with automatic attachments.

⁶ Armstrong epoxy resin C-4 with activator "D," supplied by Armstrong Products Co., Inc., Warsaw, IN, and Helix Bonding Agent R-283 with hardner B, supplied by Carl H. Biggs Co., Inc., 1547 14th St., Santa Monica, CA, are suitable.

⁷ Orthofire Separator, produced by Vernon-Benshoff Co., Pittsburgh, PA, and S-122 Fluorocarbon release agent, produced by Miller-Stephenson Chemical Co., Inc., Chicago, IL have been found suitable for this purpose. The precautions listed on the label should be followed when using the first material.

⁸ Texmet, supplied by Buehler, Ltd., 2120 Greenwood St., Evanston, IL, and Politex, supplied by Geoscience Instruments Corp., 110 Beckman St., New York, NY, have been found suitable for this purpose.