**Wood-based panels — Determination of
formaldehyde release —**

**Part 4:
Desiccator method**

*Panneaux à base de bois — Détermination du dégagement de
formaldéhyde —*

iTeh STANDARD PREVIEW
(standards.iteh.ai)
Partie 4: Méthode au dessiccateur

[ISO 12460-4:2008](https://standards.iteh.ai/catalog/standards/sist/240b874d-96c2-4516-b3b6-5032e25dd0ad/iso-12460-4-2008)

[https://standards.iteh.ai/catalog/standards/sist/240b874d-96c2-4516-
b3b6-5032e25dd0ad/iso-12460-4-2008](https://standards.iteh.ai/catalog/standards/sist/240b874d-96c2-4516-b3b6-5032e25dd0ad/iso-12460-4-2008)



PDF disclaimer

This PDF file may contain embedded typefaces. In accordance with Adobe's licensing policy, this file may be printed or viewed but shall not be edited unless the typefaces which are embedded are licensed to and installed on the computer performing the editing. In downloading this file, parties accept therein the responsibility of not infringing Adobe's licensing policy. The ISO Central Secretariat accepts no liability in this area.

Adobe is a trademark of Adobe Systems Incorporated.

Details of the software products used to create this PDF file can be found in the General Info relative to the file; the PDF-creation parameters were optimized for printing. Every care has been taken to ensure that the file is suitable for use by ISO member bodies. In the unlikely event that a problem relating to it is found, please inform the Central Secretariat at the address given below.

iTeh STANDARD PREVIEW
(standards.iteh.ai)

[ISO 12460-4:2008](https://standards.iteh.ai/catalog/standards/sist/240b874d-96c2-4516-b3b6-5032e25dd0ad/iso-12460-4-2008)

<https://standards.iteh.ai/catalog/standards/sist/240b874d-96c2-4516-b3b6-5032e25dd0ad/iso-12460-4-2008>



COPYRIGHT PROTECTED DOCUMENT

© ISO 2008

All rights reserved. Unless otherwise specified, no part of this publication may be reproduced or utilized in any form or by any means, electronic or mechanical, including photocopying and microfilm, without permission in writing from either ISO at the address below or ISO's member body in the country of the requester.

ISO copyright office
Case postale 56 • CH-1211 Geneva 20
Tel. + 41 22 749 01 11
Fax + 41 22 749 09 47
E-mail copyright@iso.org
Web www.iso.org

Published in Switzerland

Foreword

ISO (the International Organization for Standardization) is a worldwide federation of national standards bodies (ISO member bodies). The work of preparing International Standards is normally carried out through ISO technical committees. Each member body interested in a subject for which a technical committee has been established has the right to be represented on that committee. International organizations, governmental and non-governmental, in liaison with ISO, also take part in the work. ISO collaborates closely with the International Electrotechnical Commission (IEC) on all matters of electrotechnical standardization.

International Standards are drafted in accordance with the rules given in the ISO/IEC Directives, Part 2.

The main task of technical committees is to prepare International Standards. Draft International Standards adopted by the technical committees are circulated to the member bodies for voting. Publication as an International Standard requires approval by at least 75 % of the member bodies casting a vote.

Attention is drawn to the possibility that some of the elements of this document may be the subject of patent rights. ISO shall not be held responsible for identifying any or all such patent rights.

ISO 12460-4 was prepared by Technical Committee ISO/TC 89, *Wood-based panels*.

ISO 12460 consists of the following parts, under the general title *Wood-based panels — Determination of formaldehyde release*:

- *Part 1: Formaldehyde emission by the 1-cubic-metre chamber method*
- *Part 2: Small-scale chamber method* [ISO 12460-4:2008](https://standards.iteh.ai/catalog/standards/sist/240b874d-96c2-4516-b3b6-5032e25dd0ad/iso-12460-4-2008)
- *Part 3: Gas analysis method*
- *Part 4: Desiccator method*

The extraction (or perforation) method will form the subject of a future Part 5.

Introduction

ISO 12460-1 specifies the 1-cubic-metre chamber reference method for the determination of formaldehyde release. Derived test methods specified in ISO 12460-2, ISO 12460-3 and ISO 12460-4 are intended for factory production control.

iTeh STANDARD PREVIEW (standards.iteh.ai)

[ISO 12460-4:2008](https://standards.iteh.ai/catalog/standards/sist/240b874d-96c2-4516-b3b6-5032e25dd0ad/iso-12460-4-2008)

<https://standards.iteh.ai/catalog/standards/sist/240b874d-96c2-4516-b3b6-5032e25dd0ad/iso-12460-4-2008>

Wood-based panels — Determination of formaldehyde release —

Part 4: Desiccator method

1 Scope

This part of ISO 12460 specifies a desiccator method for the determination of the quantity of formaldehyde emitted from particleboard, fibreboard, plywood, oriented strand board (OSB), and wooden laminated flooring.

NOTE This part of ISO 12460 is equivalent to JANS 16^[4], harmonized between Australia, Japan and New Zealand.

2 Normative references

The following referenced documents are indispensable for the application of this document. For dated references, only the edition cited applies. For undated references, the latest edition of the referenced document (including any amendments) applies.

ISO 16999, *Wood-based panels — Sampling and cutting of test pieces*
ISO 12460-4:2008
http://standards.iso.org/iso/12460-4:2008/iso-12460-4-2008

3 Principle

Emission of formaldehyde is determined by placing test pieces of known surface area in a desiccator at a controlled temperature and measuring the quantity of emitted formaldehyde absorbed in a specified volume of water during 24 h.

4 Reagents

Use only reagents of recognized analytical grade, unless otherwise specified, and distilled or demineralized water or water of equivalent purity.

4.1 Acetylacetone-ammonium acetate solution.

Dissolve 150 g ammonium acetate ($C_2H_3O_2NH_4$) in 800 ml water in a 1 000 ml one-mark volumetric flask (5.9). Add 3 ml glacial acetic acid ($C_2H_4O_2$) and 2 ml acetylacetone (pentane-2,4-dione, $C_5H_8O_2$) and mix thoroughly into the solution. Make up to the mark with water. During storage, protect the solution from light. Discard the solution 3 days after preparation.

4.2 Iodine standard solution, $c(I_2) = 0,05 \text{ mol/l}$.

Standardize the solution before use.

4.3 Sodium thiosulfate standard solution, $c(\text{Na}_2\text{S}_2\text{O}_3) = 0,1 \text{ mol/l}$.

Standardize the solution before use.

4.4 Sodium hydroxide standard solution, $c(\text{NaOH}) = 1 \text{ mol/l}$.

Standardize the solution before use.

4.5 Sulfuric acid standard solution, $c(\text{H}_2\text{SO}_4) = 1 \text{ mol/l}$.

Standardize the solution before use.

4.6 Starch solution, 1 % mass fraction.

5 Apparatus

Usual laboratory apparatus and in particular the following.

5.1 Glass desiccators, with an enclosed volume of $(11 \pm 2) \text{ l}$ capable of enclosing a support (5.2).

5.2 Wire grid or support, of diameter $(240 \pm 15) \text{ mm}$, of stainless steel wire such that the distance between parallel pieces of wire is not less than 15 mm (see Figure 1).

5.3 Glass crystallizing dish, circular, of inside diameter $(115 \pm 1) \text{ mm}$ and depth $(60 \pm 2) \text{ mm}$.

5.4 Sample holder, of stainless steel wire, to hold the test pieces upright in the desiccator (see Figure 2).

5.5 Temperature-measuring device, e.g. a thermocouple, capable of measuring temperature with an error limit of $\pm 0,1 \text{ }^\circ\text{C}$, placed inside a desiccator (5.1) located adjacent to the desiccator(s) containing the test pieces.

5.6 Spectrophotometer, capable of measuring absorbance at 412 nm. The use of cells of pathlength at least 50 mm is recommended.

5.7 Water bath, capable of maintaining a temperature of $(65 \pm 2) \text{ }^\circ\text{C}$.

5.8 Volumetric flasks, six, of capacity 100 ml.

5.9 Volumetric flasks, two, of capacity 1 000 ml.

5.10 Bulb pipettes, of capacities 5 ml, 10 ml, 15 ml, 20 ml, 25 ml, 50 ml, and 100 ml or suitable **auto pipette**.

5.11 Microburette or auto dispenser.

5.12 Flasks with stoppers, of capacity 100 ml.

5.13 Balance, capable of measuring to 0,001 g.

6 Test pieces

6.1 Sampling

Sampling and cutting of the test pieces shall be carried out in accordance with ISO 16999.

Dimensions in millimetres

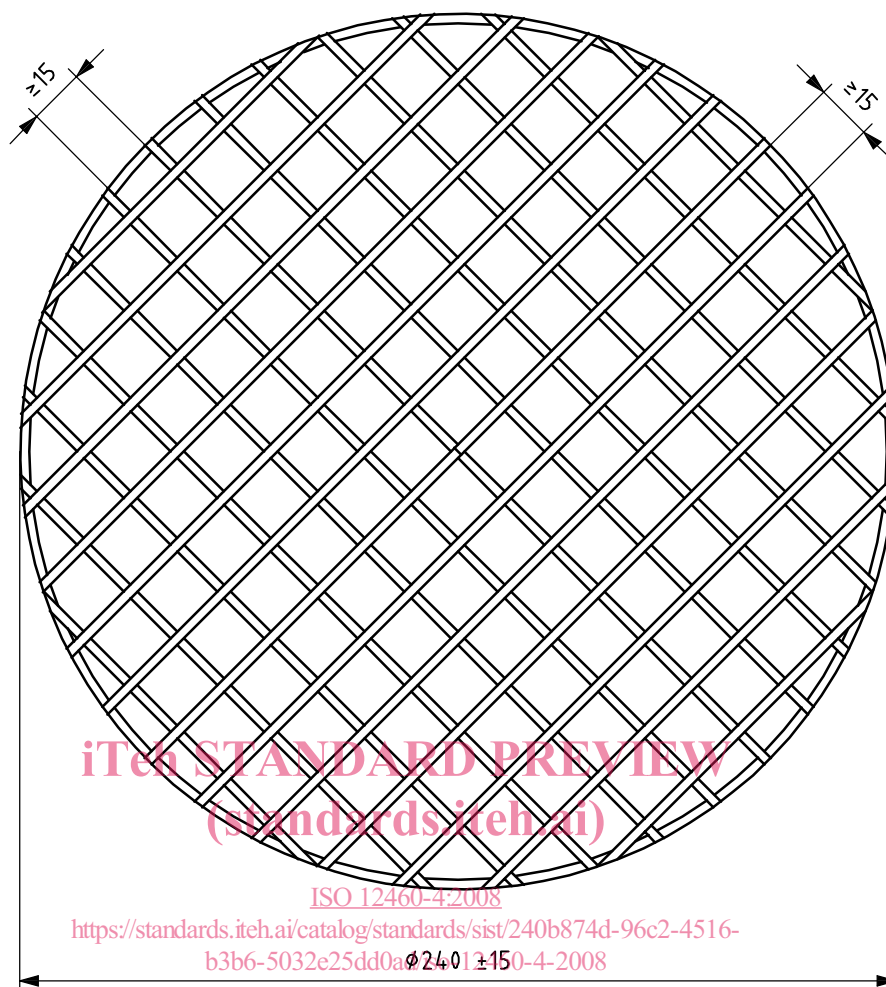
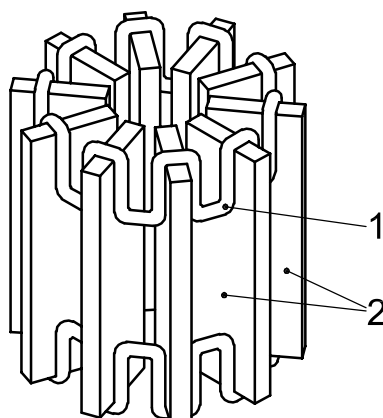

Figure 1 — Stainless steel wire grid for supporting the test pieces in the desiccator



Key

- 1 supporting metal
- 2 test pieces

Figure 2 — Example of wire sample holder to hold the test pieces in the desiccator

6.2 Dimensions

The test pieces, of thickness, δ , in millimetres, shall be of length $(150 \pm 1,0)$ mm and of width $(50 \pm 1,0)$ mm.

6.3 Number of test pieces

The number of test pieces shall be determined by their total surface area. The sum of the areas of the ends, sides and faces shall be as close as possible to $1\,800\text{ cm}^2$.

6.4 Number of emission tests

The emission tests shall be carried out in duplicate.

NOTE For internal routine control, a single emission test may be sufficient.

The differences between emissions of the two tests shall be within 20 % of their arithmetic average, otherwise a third emission test shall be carried out.

6.5 Conditioning

Condition the test pieces for 7 days or to constant mass in an atmosphere with a mean relative humidity of (65 ± 5) % and a temperature of (20 ± 2) °C.

Constant mass is considered to have been reached when the results of two successive weighing operations, carried out at an interval of 24 h, do not differ by more than 0,1 % of the mass of the test piece.

The test pieces to be conditioned shall be separated by at least 25 mm and positioned so that air can circulate freely over all surfaces.

Test pieces containing low levels of formaldehyde will absorb formaldehyde from the atmosphere when background levels of formaldehyde are high. Care should be taken to avoid such conditions during storage and conditioning by use of a formaldehyde removal system or by maintaining low volumes of test pieces in the room. The background level is measured by exposing a glass crystallizing dish (5.3) containing 300 ml water to the conditioning atmosphere for 24 h, and analysing the resulting solution. The maximum background level should be less than the nominal emission level of the test pieces (e.g. for test pieces from a sample with expected emissions of 0,3 mg/l, the background levels should be less than 0,3 mg/l).

7 Procedure

7.1 Desiccator preparation

7.1.1 New desiccators

Thoroughly clean new desiccators and those previously used for purposes other than the determination of formaldehyde.

7.1.2 Before each determination

Rinse the desiccator (5.1) and the glass dish (5.3) with water and dry them before each determination. Place (300 ± 1) ml of water at (20 ± 1) °C in the glass dish (5.3), and locate it centrally at the bottom of the desiccator. Position the wire mesh support (5.2) above the glass dish within the desiccator.

7.2 Test conditions

Place the desiccator on a vibration-free surface in an environment capable of maintaining the air temperature inside the desiccator at $(20 \pm 0,5) ^\circ\text{C}$.

7.3 Positioning of the test pieces

Insert the test pieces, free of any loose particles, into the wire sample holder (5.4) before placing it inside the desiccator. Position the sample holder containing the test pieces inside the desiccator at the centre of the wire mesh support so that it is located directly above the glass dish.

7.4 Monitoring of test conditions

7.4.1 Temperature

Prepare a control desiccator (5.1) as specified in 7.1.2 but containing no test pieces, and fit it with a temperature-measuring device (5.5). Monitor the temperature inside the desiccator continuously, or at intervals not exceeding 15 min, and record the mean temperature during the test period.

Alternatively, the temperature may be monitored by locating the temperature-measuring device (5.5) in the test environment adjacent to the desiccator.

7.4.2 Background formaldehyde

Measure the background formaldehyde in the testing environment using the control desiccator (7.4.1). The maximum accepted background level is 0,05 mg/l.

7.5 Test duration

The duration of the test shall be $24 \text{ h} \pm 10 \text{ min}$.

7.6 Sample collection

Thoroughly mix the formaldehyde solution contained in the glass dish. Rinse a 100 ml one-mark volumetric flask (5.8) with the formaldehyde solution and then fill it to the mark with the solution. Use a glass stopper to seal the flask. If the sample is not to be analysed immediately, stored it between $0 ^\circ\text{C}$ and $5 ^\circ\text{C}$ for a maximum of 30 h.

Follow the same procedure for the measurement of background formaldehyde.

8 Determination of formaldehyde

8.1 General

Determine the formaldehyd content of the aqueous solutions photometrically by the acetylacetone method.

8.2 Principle

The determination is based on the Hantzsch reaction in which the formaldehyde reacts with ammonium ions and acetylacetone to yield diacetyldihydrotoluidine (DDL). DDL has an absorption maximum at 412 nm. The reaction is specific to formaldehyde (see Reference [5]).

8.3 Procedure

Pipette (5.10) 25 ml of the formaldehyde solution to be analysed into a 100 ml flask (5.12), add 25 ml of the acetylacetone-ammonium acetate solution (4.1) and seal the flask with a stopper.