



Standard Test Method for Distillation of Pitch¹

This standard is issued under the fixed designation D 2569; the number immediately following the designation indicates the year of original adoption or, in the case of revision, the year of last revision. A number in parentheses indicates the year of last reapproval. A superscript epsilon (ϵ) indicates an editorial change since the last revision or reapproval.

^{ε1} NOTE—Replaced the word “asbestos” in 8.1.1 editorially in August 2005.

1. Scope

1.1 This test method covers a distillation test for pitch applicable whenever the amount of distillate below 270°C is less than 2.0 % by this test method.

1.2 The values stated in SI units are to be regarded as the standard. The values given in parentheses are for information only.

1.3 *This standard does not purport to address all of the safety concerns, if any, associated with its use. It is the responsibility of the user of this standard to establish appropriate safety and health practices and determine the applicability of regulatory limitations prior to use.*

2. Referenced Documents

2.1 *ASTM Standards:*

D 140 Practice for Sampling Bituminous Materials²

E 1 Specification for ASTM Thermometers³

3. Summary of Test Method

3.1 A 100-g sample is distilled from an electrically heated flask in a shield at a designated rate. The weight of distillate fractions at specified temperatures and the time required to collect the main fraction are recorded.

4. Significance and Use

4.1 In usual practice, most of the oils distilling below 360°C are removed in the manufacture of high-softening-point pitches. Excessive distillation in this range may indicate an abnormal product which could cause some problems of fuming and instability in use.

5. Apparatus

5.1 *Flask*—A side-arm distillation flask, as shown in Fig. 1, having the following dimensions:

Diameter of bulb, outside, mm	86.0 ± 1.5
Diameter of neck, inside, mm	22.0 ± 1.0
Diameter of tubulature, inside, mm	10.0 ± 0.5
Height of flask, outside, mm	131.0 ± 1.5
Vertical distance, bottom of bulb, outside, to horizontal tangent at tubulature, inside, mm	93.0 ± 1.5
Length of tubulature, mm	220 ± 5
Angle of tubulature, °	1.0 to 1.5
Thickness of tubulature wall, mm	75 ± 2

5.2 *Condenser Tube*—A tapered glass condenser, as shown in Fig. 2, having the following dimensions:

Outside diameter of small end, mm	12.5 ± 1.5
Outside diameter of large end, mm	28.5 ± 3.0
Length, mm	360 ± 4
Length of tapered part, mm	100 ± 5

5.3 *Source of Heat*—Electric heater,⁴ 750-W, with variable transformer control as shown in Fig. 2, with a direct-reading voltmeter (120 V) or ammeter (5 A). Transformer settings shall be reproducible within 2 % on the percent input dial. The heater shall be fitted with an upper refractory top, with the dimensions shown in Fig. 3, and a 110-mm square plate of 6-mm thick non-asbestos containing cement board, having an 80-mm center hole as shown in Fig. 4.

5.4 *Shield*—A stainless steel shield with mica windows⁵ lined with 3-mm thick high temperature cloth, provided with a two-piece cover of 6-mm thick transite board (non-asbestos) of the form and dimensions shown in Fig. 4.

¹ This test method is under the jurisdiction of ASTM Committee D02 on Petroleum Products and Lubricants and is the direct responsibility of Subcommittee D02.05.OF on Industrial Pitches.

Current edition approved Apr. 10, 1997. Published October 1997. Originally published as D 2569 – 67. Last previous edition D 2569 – 91.

² *Annual Book of ASTM Standards*, Vol 04.03.

³ *Annual Book of ASTM Standards*, Vol 14.03.

⁴ The Precision “Ful-Kontrol” heater meets these requirements; it can be purchased through supply houses.

⁵ The sole source of supply of the mica windows known to the committee at this time is Humboldt Mfg Co., Inc., 7302 W. Agatite Ave., Chicago, IL 60656. If you are aware of alternative suppliers, please provide this information to ASTM International Headquarters. Your comments will receive careful consideration at a meeting of the responsible technical committee,¹ which you may attend.

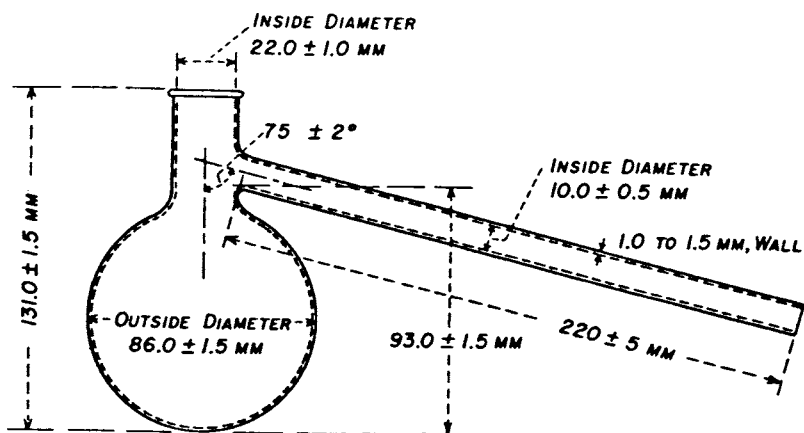

FIG. 1 Distillation Flask

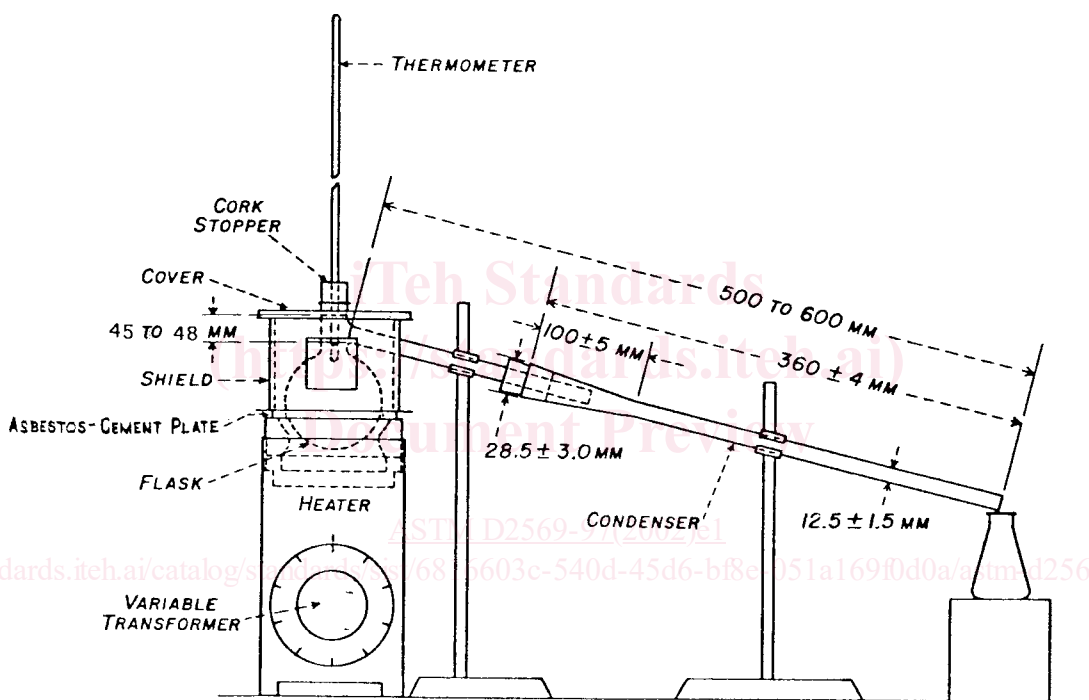

FIG. 2 Apparatus Assembly for Pitch Distillation

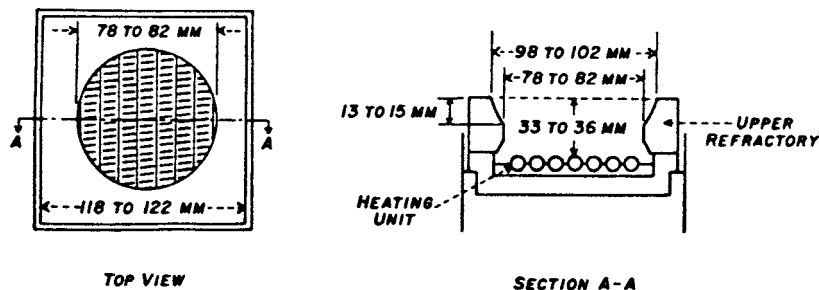

FIG. 3 Upper Part of Electric Heater

5.5 *Receivers*—Erlenmeyer flasks or beakers, having a nominal capacity of 50 to 125 mL and tared to the nearest 0.05 g.

5.6 *Thermometer*—An ASTM High Distillation Thermometer, having a range from -2 to 400°C and conforming to the

requirements for Thermometer 8C as prescribed in Specification E 1 or a suitable digital thermometer with the same precision as 8C.

5.7 *Timer*—Stop clock or stop watch, calibrated in seconds or tenths.