

---

---

**Earth-moving machinery — Operator  
enclosure environment —**

**Part 2:  
Air filter element test method**

*Engins de terrassement — Environnement de l'enceinte de  
l'opérateur —*

**iTeh STANDARD PREVIEW**  
*Partie 2: Méthode d'essai de l'élément du filtre à air*  
**(standards.iteh.ai)**

ISO 10263-2:2009

<https://standards.iteh.ai/catalog/standards/sist/e7ae0691-9fad-4c4a-90a7-f7270695e306/iso-10263-2-2009>



**PDF disclaimer**

This PDF file may contain embedded typefaces. In accordance with Adobe's licensing policy, this file may be printed or viewed but shall not be edited unless the typefaces which are embedded are licensed to and installed on the computer performing the editing. In downloading this file, parties accept therein the responsibility of not infringing Adobe's licensing policy. The ISO Central Secretariat accepts no liability in this area.

Adobe is a trademark of Adobe Systems Incorporated.

Details of the software products used to create this PDF file can be found in the General Info relative to the file; the PDF-creation parameters were optimized for printing. Every care has been taken to ensure that the file is suitable for use by ISO member bodies. In the unlikely event that a problem relating to it is found, please inform the Central Secretariat at the address given below.

**iTeh STANDARD PREVIEW**  
**(standards.iteh.ai)**

ISO 10263-2:2009

<https://standards.iteh.ai/catalog/standards/sist/e7ae0691-9fad-4c4a-90a7-f7270695e306/iso-10263-2-2009>



**COPYRIGHT PROTECTED DOCUMENT**

© ISO 2009

All rights reserved. Unless otherwise specified, no part of this publication may be reproduced or utilized in any form or by any means, electronic or mechanical, including photocopying and microfilm, without permission in writing from either ISO at the address below or ISO's member body in the country of the requester.

ISO copyright office  
Case postale 56 • CH-1211 Geneva 20  
Tel. + 41 22 749 01 11  
Fax + 41 22 749 09 47  
E-mail [copyright@iso.org](mailto:copyright@iso.org)  
Web [www.iso.org](http://www.iso.org)

Published in Switzerland

## Contents

Page

Foreword.....	iv
<b>1 Scope .....</b>	<b>1</b>
<b>2 Normative references .....</b>	<b>1</b>
<b>3 Terms and definitions.....</b>	<b>1</b>
<b>4 Air filter element performance test .....</b>	<b>1</b>
<b>5 Test report .....</b>	<b>3</b>
<b>Annex A (informative) Example of test report form for panel-type filter .....</b>	<b>7</b>
<b>Annex B (informative) Alternate method for air filter element performance evaluation.....</b>	<b>8</b>
<b>Bibliography .....</b>	<b>10</b>

## iTeh STANDARD PREVIEW (standards.iteh.ai)

ISO 10263-2:2009

<https://standards.iteh.ai/catalog/standards/sist/e7ae0691-9fad-4c4a-90a7-f7270695e306/iso-10263-2-2009>

## Foreword

ISO (the International Organization for Standardization) is a worldwide federation of national standards bodies (ISO member bodies). The work of preparing International Standards is normally carried out through ISO technical committees. Each member body interested in a subject for which a technical committee has been established has the right to be represented on that committee. International organizations, governmental and non-governmental, in liaison with ISO, also take part in the work. ISO collaborates closely with the International Electrotechnical Commission (IEC) on all matters of electrotechnical standardization.

International Standards are drafted in accordance with the rules given in the ISO/IEC Directives, Part 2.

The main task of technical committees is to prepare International Standards. Draft International Standards adopted by the technical committees are circulated to the member bodies for voting. Publication as an International Standard requires approval by at least 75 % of the member bodies casting a vote.

Attention is drawn to the possibility that some of the elements of this document may be the subject of patent rights. ISO shall not be held responsible for identifying any or all such patent rights.

ISO 10263-2 was prepared by Technical Committee ISO/TC 127, *Earth-moving machinery*, Subcommittee SC 2, *Safety, ergonomics and general requirements*.

This second edition cancels and replaces the first edition (ISO 10263-2:1994), which has been technically revised.

ISO 10263 consists of the following parts, under the general title *Earth-moving machinery — Operator enclosure environment*:

- iTeh STANDARD PREVIEW**  
**(standards.iteh.ai)**
- <https://standards.iteh.ai/catalog/standards/sist/e7ae0691-9fad-4c4a-90a7-f7270695e306/iso-10263-2-2009>
- *Part 1: Terms and definitions*
  - *Part 2: Air filter element test method*
  - *Part 3: Pressurization test method*
  - *Part 4: Heating, ventilating and air conditioning (HVAC) test method and performance*
  - *Part 5: Windscreen defrosting system test method*
  - *Part 6: Determination of effect of solar heating*

# Earth-moving machinery — Operator enclosure environment —

## Part 2: Air filter element test method

### 1 Scope

This part of ISO 10263 specifies a uniform test method to determine performance levels of operator enclosure panel-type air filters used to filter the air entering an earth-moving machine operator enclosure with a powered fresh air system.

### 2 Normative references

The following referenced documents are indispensable for the application of this document. For dated references, only the edition cited applies. For undated references, the latest edition of the referenced document (including any amendments) applies.

ISO 5011:2000, *Inlet air cleaning equipment for internal combustion engines and compressors — Performance testing*

ISO 10263-1, *Earth-moving machinery — Operator enclosure environment — Part 1: Terms and definitions*  
<https://standards.iteh.ai/catalog/standards/sist/e7ae0691-9fad-4c4a-90a7-5730-05406/iso-10263-2009>

ISO 12103-1, *Road vehicles — Test dust for filter evaluation — Part 1: Arizona test dust*

### 3 Terms and definitions

For the purposes of this document, the terms and definitions given in ISO 10263-1 and the following apply.

#### 3.1

##### **filter efficiency**

measure of the ability of the air filter element to remove particulate matter

#### 3.2

##### **operator enclosure air filter element**

medium in which particulate matter is removed from the incoming air supply

#### 3.3

##### **test dust**

particulate matter used to evaluate the filter element

### 4 Air filter element performance test

The test shroud configurations for the operator enclosure filter comparison tests are given in 4.1.1 and Figure 1. This test procedure also designates a recommended intake velocity for the dust-mixing chamber.

## 4.1 Test equipment and instruments

### 4.1.1 Test equipment

Test equipment in accordance with Figure 2, used to determine the resistance to air flow, particulate holding capacity, particulate removal efficiency, and sealing characteristics. For element configurations other than panel type, see ISO 5011.

### 4.1.2 Dust metering device

Dust metering device used in accordance with Figure 3 and the dust injector in Figure 4 is capable of metering dust over the range of delivery rates required. This dust feed system shall not change the primary particle size distribution of the particulate. The average delivery rate shall be within 5 % of the desired rate and the deviation in the instantaneous delivery rate from the average shall be no more than 5 %.

## 4.2 Test conditions and material

**4.2.1** All air flow measurements are to be corrected to a standard condition of 25 °C at 100 kPa.

**4.2.2** Test dust shall be standardized and shall be of two grades labelled ISO 12103-A2 (fine) and ISO 12103-A4 (coarse). For typical particle size distribution and chemical composition, refer to ISO 12103-1.

It is difficult to select a test dust size distribution and concentration which will be representative of all service conditions, therefore based primarily on practical considerations, the concentration shall be 1 g/m<sup>3</sup> for A2 and A4 dusts (1 g/m<sup>3</sup> is generally accepted as zero visibility conditions).

**4.2.3** The absolute filter shall consist of fibreglass medium with a minimum thickness of 12,7 mm and a minimum density of 9,5 kg/m<sup>3</sup>. The fibre diameter shall be 0,76 µm to 1,27 µm and the moisture absorption shall be less than 1 % by weight after exposure to 50 °C and 95 % relative humidity for 96 h. The filter shall be installed with the nap side facing upstream in an airtight holder that adequately supports the medium. The face velocity shall not exceed 50 m/min to maintain medium integrity.

**4.2.4** The mass of the absolute filter shall be measured to the nearest 0,01 g after the weight has stabilized and while in a ventilation oven at (105 ± 5) °C.

**4.2.5** All tests shall be conducted with air entering the air filter at a temperature of (24 ± 8) °C and a relative humidity of (50 ± 15) %.

NOTE Since atmospheric conditions affect test results, when comparing performance of filters designed for the same application, tests are conducted within the narrowest range of temperature and humidity possible.

**4.2.6** The velocity of the air entering the top of the dust mixing chamber shall be a minimum of 6 m/s. See Figure 1.

**4.2.7** Air flow restriction and pressure drop tests shall be conducted using a minimum of three points: 80 %, 100 % and 120 % of rated air flow using the element restriction test setup shown in Figure 2. Condition the unit to be tested for at least 30 min under temperature and humidity conditions equivalent to those of the test area.

**4.2.8** The air filter efficiency,  $E$ , as a percentage, is calculated as given in Equation (1):

$$E = \frac{\Delta m_t}{\Delta m_t + \Delta m_A} \times 100 \quad (1)$$

where

$\Delta m_t$  is the increase in mass of the filter element under test;

$\Delta m_A$  is the increase in mass of the absolute filter.

The alternative efficiency method is given in Annex B.

## 5 Test report

A sample test report form for panel-type air filters is given in Annex A.

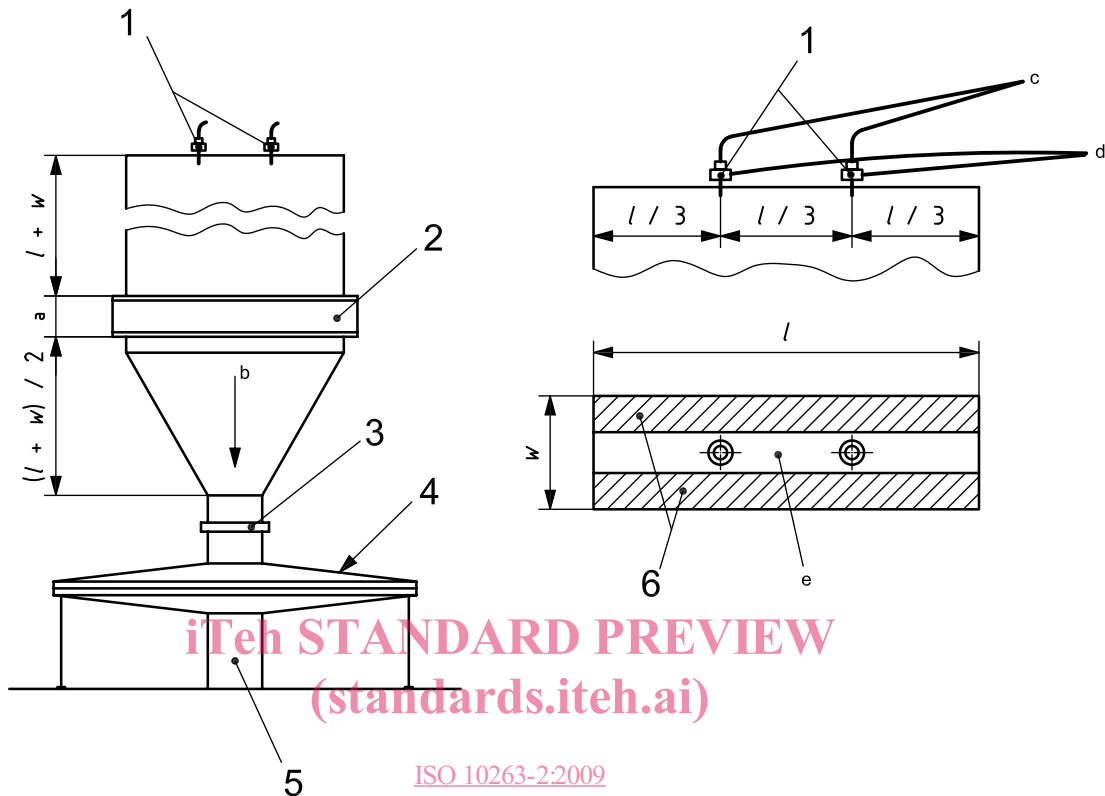

iTeh STANDARD PREVIEW  
(standards.iteh.ai)

ISO 10263-2:2009  
<https://standards.iteh.ai/catalog/standards/sist/e7ae0691-9fad-4c4a-90a7-f7270695e306/iso-10263-2-2009>

### Key

- 1 dust injectors
  - 2 filter element being tested
  - 3 piezometer ring
  - 4 absolute filter housing
  - 5 blower
  - 6 restrictor plates
- a Filter depth.
  - b Flow.
  - c Compressed air.
  - d From dust feeder.
  - e Velocity calculated between top restrictor plates.

**Figure 1 — Test shroud**

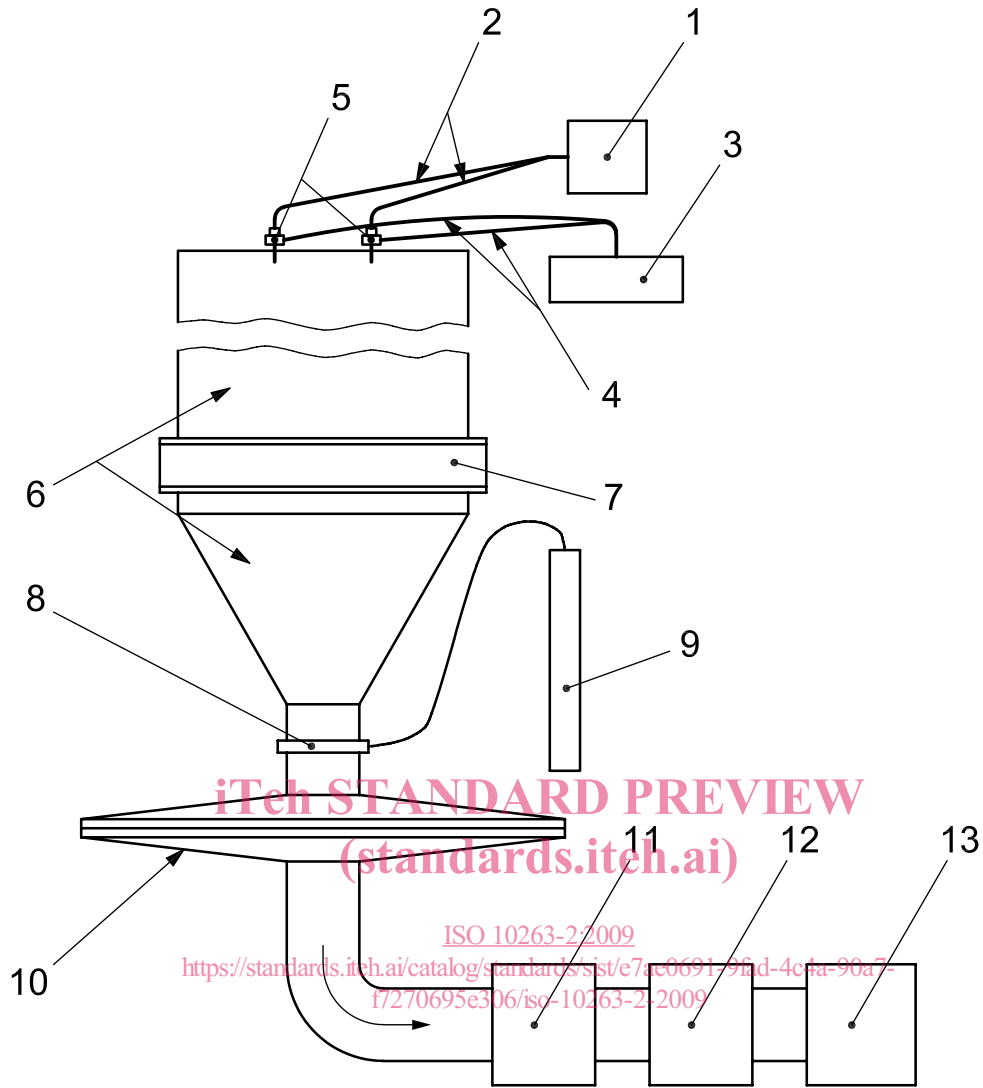

**Key**

- 1 compressed air supply
- 2 compressed air lines
- 3 dust metering device
- 4 dust transfer tubing
- 5 dust injectors
- 6 test shroud
- 7 filter element being tested
- 8 piezometer ring
- 9 restriction measuring device
- 10 absolute filter housing
- 11 flow rate measuring device
- 12 flow rate control system
- 13 blower or other device for inducing air flow

**Figure 2 — Test equipment setup**

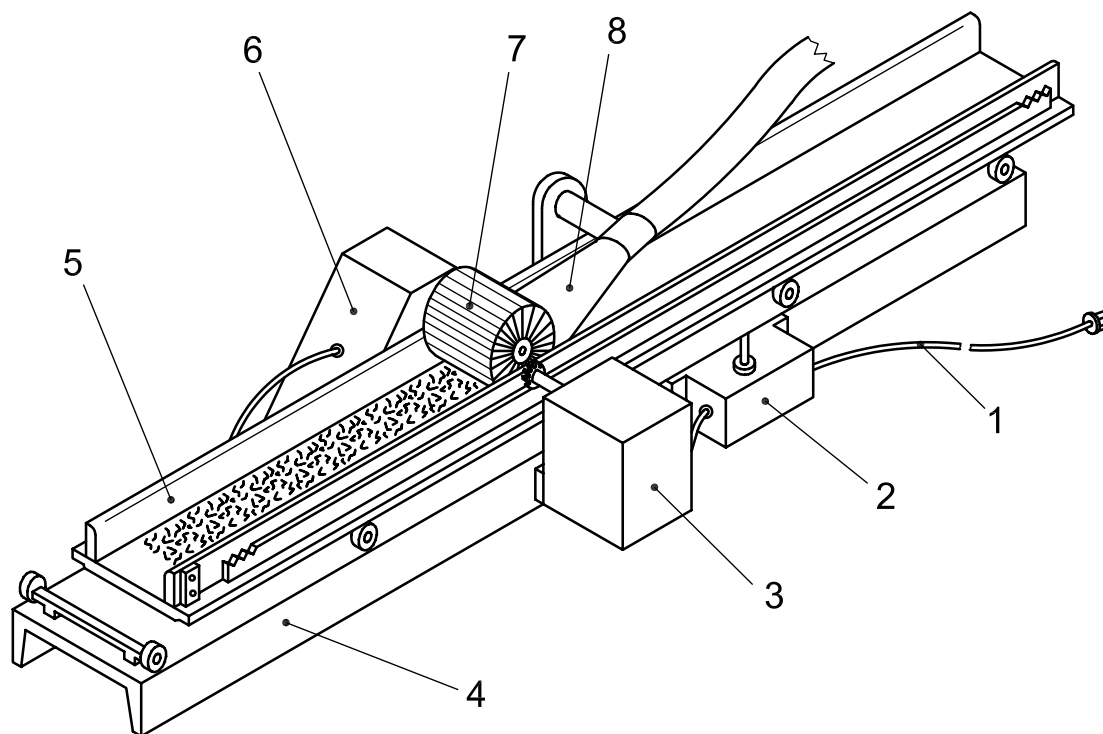

**Key**

- 1 power cord
- 2 control box
- 3 tray drive motor
- 4 guide base
- 5 dust tray
- 6 brush drive motor
- 7 feeder brush
- 8 aspirator manifold

**iTeh STANDARD PREVIEW**  
**(standards.iteh.ai)**

ISO 10263-2:2009

<https://standards.iteh.ai/catalog/standards/sist/e7ae0691-9fad-4c4a-90a7-f7270695e306/iso-10263-2-2009>

**Figure 3 — Dust feeder**