

---

---

**Rolling bearings — Profiled rail guides  
for linear motion rolling bearings —**

Part 1:

**Boundary dimensions and tolerances for  
series 1, 2 and 3**

**iTeh STANDARD PREVIEW**  
*Roulements — Guidages sur rail profilé pour roulements pour  
mouvement linéaire —*  
**(standards.iteh.ai)**

*Partie 1: Dimensions d'encombrement et tolérances pour les séries 1, 2  
et 3*

ISO 12090-1:2011

<https://standards.iteh.ai/catalog/standards/sist/357a40aa-8d16-4990-9c0e-8c07ded2bc09/iso-12090-1-2011>



**iTeh STANDARD PREVIEW**  
**(standards.iteh.ai)**

ISO 12090-1:2011

<https://standards.iteh.ai/catalog/standards/sist/357a40aa-8d16-4990-9c0e-8c07ded2bc09/iso-12090-1-2011>



**COPYRIGHT PROTECTED DOCUMENT**

© ISO 2011

All rights reserved. Unless otherwise specified, no part of this publication may be reproduced or utilized in any form or by any means, electronic or mechanical, including photocopying and microfilm, without permission in writing from either ISO at the address below or ISO's member body in the country of the requester.

ISO copyright office  
Case postale 56 • CH-1211 Geneva 20  
Tel. + 41 22 749 01 11  
Fax + 41 22 749 09 47  
E-mail [copyright@iso.org](mailto:copyright@iso.org)  
Web [www.iso.org](http://www.iso.org)

Published in Switzerland

**Contents**

Page

<b>Foreword</b> .....	<b>iv</b>
<b>1 Scope</b> .....	<b>1</b>
<b>2 Normative references</b> .....	<b>1</b>
<b>3 Terms and definitions</b> .....	<b>1</b>
<b>4 Symbols</b> .....	<b>4</b>
<b>5 Design types</b> .....	<b>5</b>
<b>5.1 Carriages</b> .....	<b>5</b>
<b>5.2 Profiled rails</b> .....	<b>6</b>
<b>6 Boundary dimensions</b> .....	<b>6</b>
<b>6.1 Profiled rail guides</b> .....	<b>6</b>
<b>6.2 Profiled rails</b> .....	<b>12</b>
<b>7 Tolerances</b> .....	<b>13</b>
<b>Annex A (informative) General length tolerances for profiled rails</b> .....	<b>15</b>

**iTeh STANDARD PREVIEW**  
**(standards.iteh.ai)**

ISO 12090-1:2011

<https://standards.iteh.ai/catalog/standards/sist/357a40aa-8d16-4990-9c0e-8c07ded2bc09/iso-12090-1-2011>

## Foreword

ISO (the International Organization for Standardization) is a worldwide federation of national standards bodies (ISO member bodies). The work of preparing International Standards is normally carried out through ISO technical committees. Each member body interested in a subject for which a technical committee has been established has the right to be represented on that committee. International organizations, governmental and non-governmental, in liaison with ISO, also take part in the work. ISO collaborates closely with the International Electrotechnical Commission (IEC) on all matters of electrotechnical standardization.

International Standards are drafted in accordance with the rules given in the ISO/IEC Directives, Part 2.

The main task of technical committees is to prepare International Standards. Draft International Standards adopted by the technical committees are circulated to the member bodies for voting. Publication as an International Standard requires approval by at least 75 % of the member bodies casting a vote.

Attention is drawn to the possibility that some of the elements of this document may be the subject of patent rights. ISO shall not be held responsible for identifying any or all such patent rights.

ISO 12090-1 was prepared by Technical Committee ISO/TC 4, *Rolling bearings*, Subcommittee SC 11, *Linear motion rolling bearings*.

ISO 12090 consists of the following parts, under the general title *Rolling bearings — Profiled rail guides for linear motion rolling bearings*:

— *Part 1: Boundary dimensions and tolerances for series 1, 2 and 3*

— *Part 2: Boundary dimensions and tolerances for series 4 and 5*

iTeh STANDARD PREVIEW  
(standards.iteh.ai)

[ISO 12090-1:2011](https://standards.iteh.ai/catalog/standards/sist/357a40aa-8d16-4990-9c0e-8c07ded2bc09/iso-12090-1-2011)

<https://standards.iteh.ai/catalog/standards/sist/357a40aa-8d16-4990-9c0e-8c07ded2bc09/iso-12090-1-2011>

# Rolling bearings — Profiled rail guides for linear motion rolling bearings —

## Part 1: Boundary dimensions and tolerances for series 1, 2 and 3

### 1 Scope

This part of ISO 12090 establishes the boundary dimensions and tolerances for series 1, 2 and 3 of linear motion rolling bearings, profiled rail guides.

These bearings consist of profiled rails with carriages, which can support forces from all perpendicular directions and moments around all axes and consist of recirculating rolling elements. The internal design of these profiled rail guides is at the discretion of the manufacturer.

An assembly, as specified by the manufacturer, can comprise one or more carriages on a profiled rail. Therefore, the interchange or combination of these elements can only be carried out within the limits permitted by the manufacturer.

### 2 Normative references

[ISO 12090-1:2011](https://standards.iteh.ai/catalog/standards/sist/357a40aa-8d16-4990-9c0e-8c07ded2bc09/iso-12090-1-2011)

The following referenced documents are indispensable for the application of this document. For dated references, only the edition cited applies. For undated references, the latest edition of the referenced document (including any amendments) applies.

ISO 1132-1, *Rolling bearings — Tolerances — Part 1: Terms and definitions*

ISO 5593, *Rolling bearings — Vocabulary*

ISO 15241, *Rolling bearings — Symbols for quantities*

ISO 24393, *Rolling bearings — Linear motion rolling bearings — Vocabulary*

### 3 Terms and definitions

For the purposes of this document, the terms and definitions given in ISO 1132-1, ISO 5593, ISO 24393 and the following apply.

#### 3.1

##### **linear rail guide**

profiled rail guide

⟨monorail guidance system⟩ linear motion rolling bearing unit consisting of a profiled rail or profiled guideway and one or more ball carriages or roller carriages

NOTE Adapted from ISO 24393:2008, definition 02.02.01.

3.2

**ball carriage profiled rail guide**

linear rail guide consisting of one or more ball carriages and a profiled rail or profiled guideway

[ISO 24393:2008, definition 02.02.03]

NOTE The amount of linear movement (stroke length) is unlimited as the ball carriage has a ball recirculating feature.

3.3

**roller carriage profiled rail guide**

linear rail guide consisting of one or more roller carriages and a profiled rail or profiled guideway

[ISO 24393:2008, definition 02.02.04]

NOTE The amount of linear movement (stroke length) is unlimited as the roller carriage has a roller recirculating feature.

3.4

**ball carriage**

linear bearing subassembly consisting of a ball carriage body and a number of closed loops of recirculating balls, which is designed to achieve unlimited motion along a profiled rail or profiled guideway

[ISO 24393:2008, definition 03.01.02]

3.5

**roller carriage**

linear bearing subassembly consisting of a roller carriage body and a number of closed loops of recirculating rollers, which is designed to achieve unlimited motion along a profiled rail or profiled guideway

[ISO 24393:2008, definition 03.01.03]

iTeh STANDARD PREVIEW  
(standards.iteh.ai)

[ISO 12090-1:2011](https://standards.iteh.ai/catalog/standards/sist/357a40aa-8d16-4990-9c0e-8c07ded2bc09/iso-12090-1-2011)

<https://standards.iteh.ai/catalog/standards/sist/357a40aa-8d16-4990-9c0e-8c07ded2bc09/iso-12090-1-2011>

3.6

**profiled rail**

profiled guideway

rail or guideway having a profiled cross-section incorporating a number of raceways along which a ball carriage or a roller carriage traverses

NOTE Adapted from ISO 24393:2008, definition 04.01.15.

3.7

**nominal carriage width**

$A$   
distance between the two faces of a carriage

3.8

**reference face of a carriage**

face of a carriage designated as the reference face by the manufacturer of the guide and which can be the datum for measurements

3.9

**reference face of a profiled rail**

face of a profiled rail designated as the reference face by the manufacturer of the guide and which can be the datum for measurements

3.10

**nominal distance between the reference face of carriage and the reference face of the rail**

$A_1$   
distance between the two reference faces of the carriage and profiled rail (of profiled rail guide)

**3.11****deviation of the distance between the reference faces of several carriages on one rail and profiled rail** $\Delta A_1$ 

dimensional difference between the reference faces of several carriages on one rail, measured at the same point on the rail and at the centre point of the faces of several carriages

**3.12****variation of the distance between the reference faces of several carriages on several rails and profiled rail** $V_{A1}$ 

dimensional variation between the reference faces of several carriages on several rails, measured at any point on the rails and at the centre point of the reference faces of several carriages

NOTE The variation of the distance between the reference faces of carriage on several rails is calculated using Equation (1):

$$V_{A1} = A_{1,\max} - A_{1,\min} \quad (1)$$

where

$A_{1,\max}$  is the maximum distance between the reference faces of the carriages and profiled rails;

$A_{1,\min}$  is the minimum distance between the reference faces of the carriages and profiled rails.

**3.13****nominal carriage length** $B$ 

distance between the two end faces of the carriage designated to bound its length

**3.14****nominal height of profiled rail guide** $H$ 

distance between the bottom face of the profiled rail and the top face of the carriage

**3.15****deviation of the height of several carriages on one rail** $\Delta H$ 

height difference between the top faces of several carriages on one rail, measured at the same point on the rail and at the centre point of the top faces of several carriages

**3.16****variation of the height of several carriages on several rails** $V_H$ 

height variation between the top faces of several carriages on several rails, measured at any point on the rails and at the centre point of the top faces of several carriages

NOTE The variation of the height of several carriages on several rails is calculated using Equation (2):

$$V_H = H_{\max} - H_{\min} \quad (2)$$

where

$H_{\max}$  is the maximum height of profiled rail guide;

$H_{\min}$  is the minimum height of profiled rail guide.

**3.17**  
**nominal height between the bottom faces of profiled rail guide**

$H_1$   
distance between the bottom face of the profiled rail and that of the carriage designated to bound the clearance between the bottom of the carriage and the bottom of the profiled rail

**3.18**  
**nominal profiled rail width**

$W$   
distance between the two faces of the profiled rail

**3.19**  
**vertical running parallelism**

$P_V$   
running parallelism of the carriage measured at the centre point of the top face of the carriage and bottom face of the rail along the length of the rail

**3.20**  
**horizontal running parallelism**

$P_H$   
running parallelism of the carriage measured at the centre point of the reference face of the carriage and reference face of the rail along the length of the rail

**4 Symbols**

iTeh STANDARD PREVIEW

For the purposes of this document, the symbols given in ISO 15241 and the following apply.

The symbols (except those for tolerances) shown in Figures 1 to 6 and the values given in Tables 1 to 8 denote nominal dimensions unless specified otherwise.

- $A$  nominal carriage width
- $A_1$  nominal distance between the reference face of the carriage and the reference face of the rail
- $B$  nominal carriage length
- $d_1$  minor diameter of internal screw thread of carriage
- $d_2$  diameter of bore (or recess) for bolt mounting from the bottom of the carriage
- $G$  designation of internal screw thread of carriage
- $G_1$  designation of internal screw thread of profiled rail
- $H$  nominal height of profiled rail guide
- $H_1$  nominal height between the bottom faces of carriage and profiled rail
- $H_2$  height of reference face of carriage
- $h$  depth of bolt hole counterbore of profiled rail
- $h_1$  height from counterbore face to mounting face of carriage
- $J$  centre distance between bolt holes of carriage (width)



$J_1$	centre distance between bolt holes of carriage (length)
$J_2$	centre distance between bolt holes of profiled rail (length)
$J_3$	distance from the end face to the first bolt hole of profiled rail (length)
$J_5$	distance between the fifth and sixth holes in carriage (length)
$J_{11}$	half of the centre distance between bolt holes of carriages (length)
$l_G$	length of internal screw thread of carriage
$l_{G1}$	length of internal screw thread of profiled rail
$N$	diameter of bolt hole of carriage
$N_1$	diameter of bolt hole of profiled rail
$N_2$	diameter of bolt hole counterbore of profiled rail
$P_H$	horizontal running parallelism
$P_V$	vertical running parallelism
$V_{A1}$	variation of the distance between the reference faces of carriage on several rails
$V_H$	variation of the height of several carriages on several rails
$W$	nominal profiled rail width
$\Delta A_1$	deviation of the distance between the reference faces of carriages on one rail
$\Delta H$	deviation of the height of several carriages on one rail

## 5 Design types

### 5.1 Carriages

The design types of carriages are given in Table 1.

**Table 1 — Carriages for profiled rail types T and B**

Series	Design	Type
1	Standard	1M
	Standard, long	1L
2	Narrow	2M
	Narrow, long	2L
3	Narrow, increased height	3M
	Narrow, increased height, long	3L

5.2 Profiled rails

The design types of profiled rails are given in Table 2.

Table 2 — Profiled rails

Method of fixing	Type
From above	T
From below	B

6 Boundary dimensions

6.1 Profiled rail guides

6.1.1 General

Boundary dimensions for profiled rail guides of series 1, 2 and 3 are given in Tables 3, 4 and 5, respectively.

6.1.2 Series 1

The boundary dimensions for profiled rail guides of series 1 are given in Figure 1.

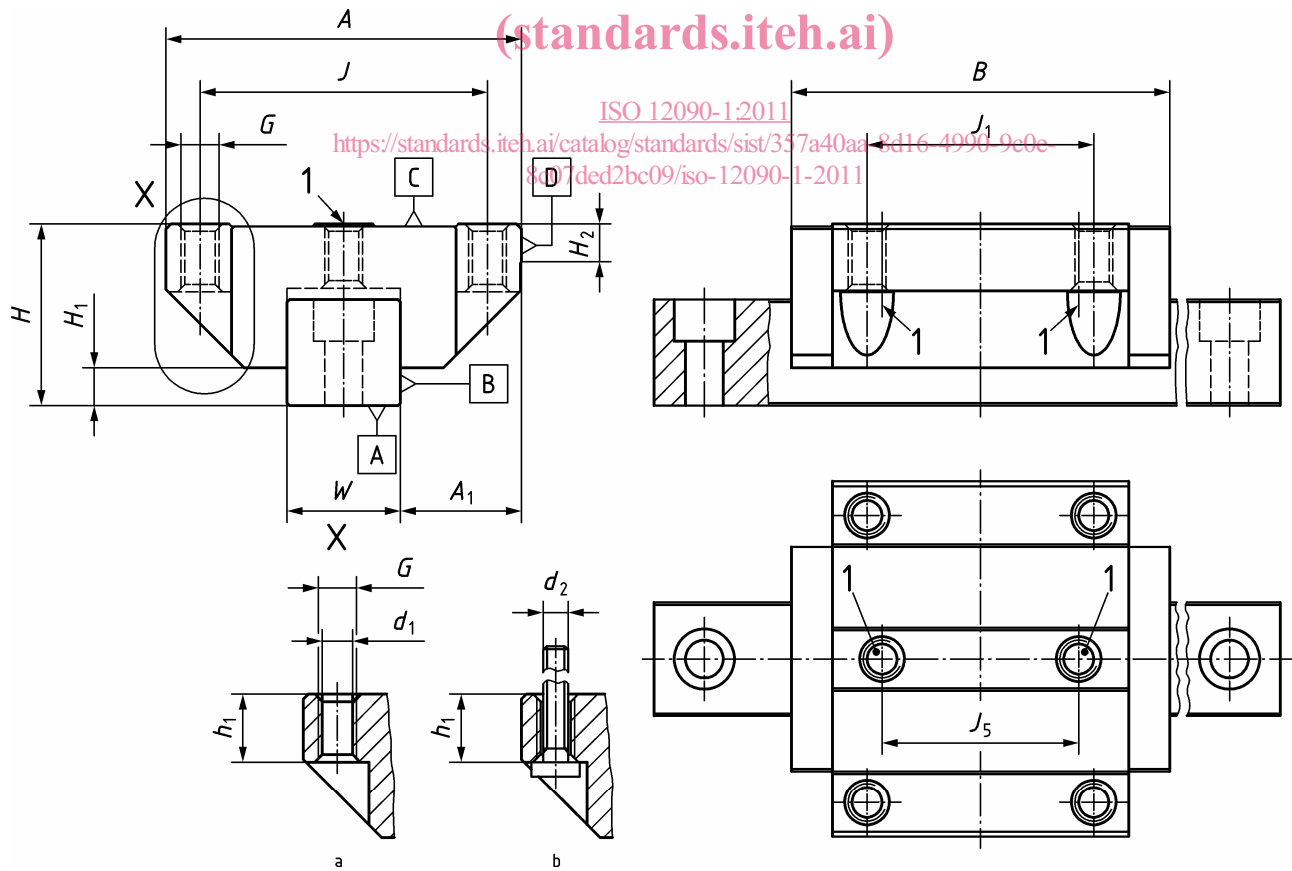

a) Sizes 15 to 85 — Carriages with threaded holes

Figure 1 (continued)

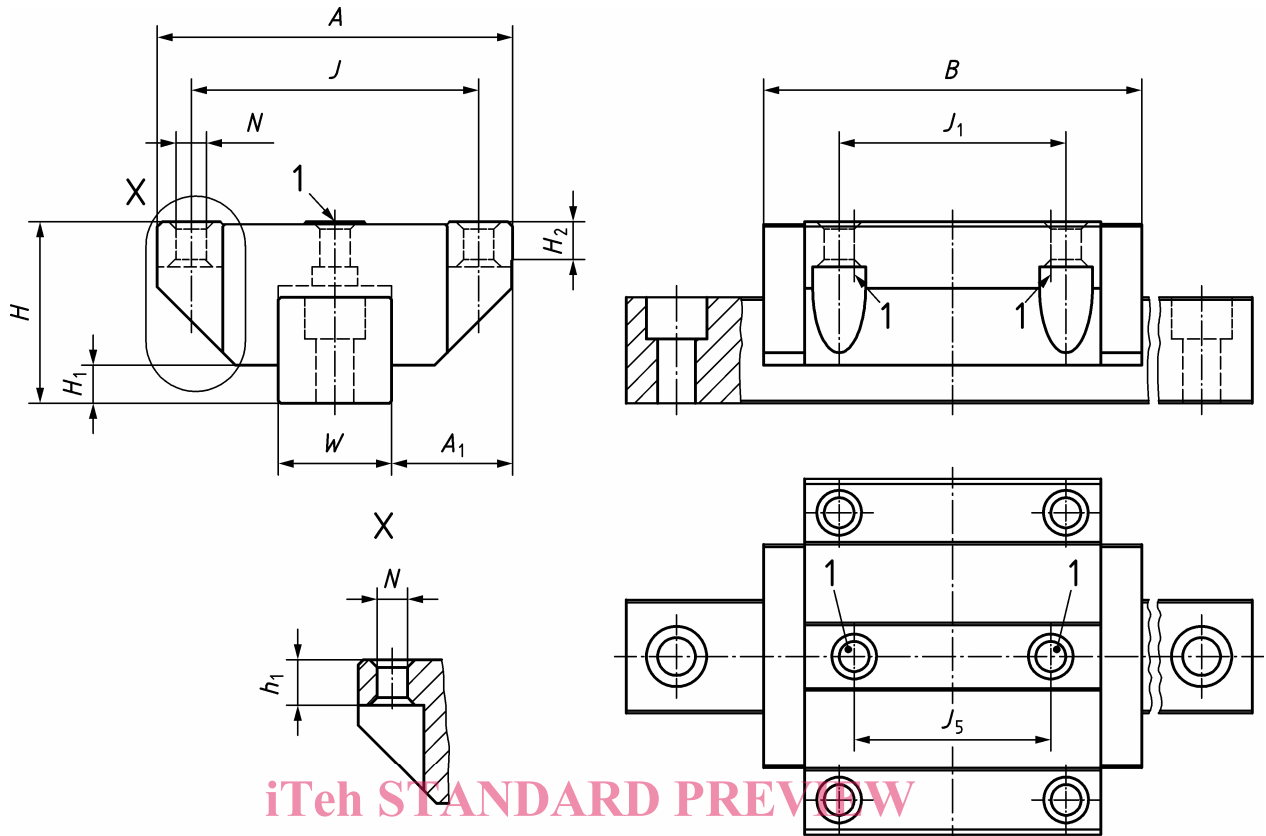

b) Sizes 15 to 85 — Carriages with through holes

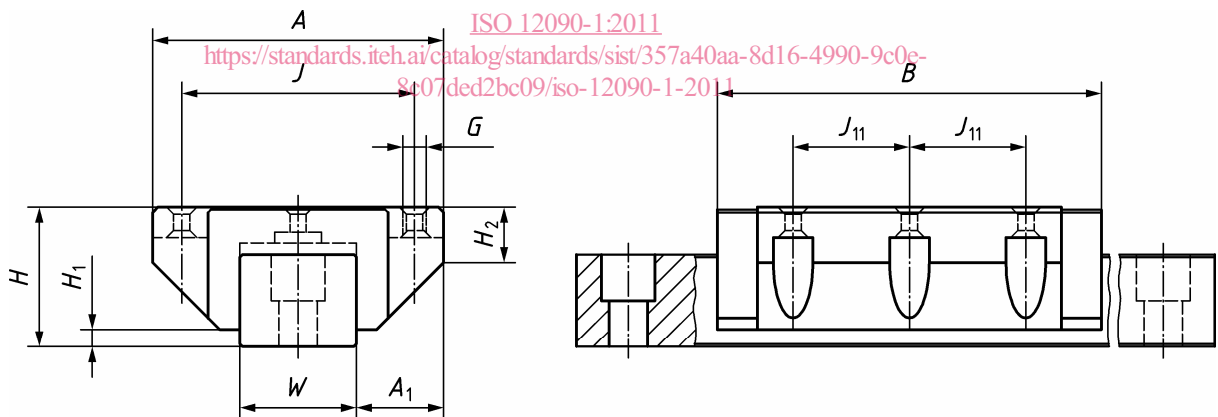

c) Sizes 100 and 125 — Carriages with threaded and through holes

**Key**

- |  |                                     |
|--|-------------------------------------|
| 1 mounting holes (depending on size and on the manufacturer) | <b>A</b> Bottom face of rail        |
| a Fixing from the top or bottom (threaded holes).            | <b>B</b> Reference face of rail     |
| b Fixing from the bottom (through holes).                    | <b>C</b> Top face of carriage       |
|  | <b>D</b> Reference face of carriage |

NOTE 1 Datum A till D applicable for Series 1, 2 and 3

NOTE 2 Carriage for sizes 100 and 125 available with threaded or through holes

**Figure 1 — Profiled rail guides — Series 1**