



Designation: D 6927 – 05<sup>ε1</sup>

## Standard Test Method for Marshall Stability and Flow of Bituminous Mixtures<sup>1</sup>

This standard is issued under the fixed designation D 6927; the number immediately following the designation indicates the year of original adoption or, in the case of revision, the year of last revision. A number in parentheses indicates the year of last reappraisal. A superscript epsilon ( $\epsilon$ ) indicates an editorial change since the last revision or reappraisal.

<sup>ε1</sup> NOTE—Editorial changes were made throughout in August 2005.

### 1. Scope

1.1 This test method covers measurement of resistance to plastic flow of 102 mm (4 in.) cylindrical specimens of bituminous paving mixture loaded in a direction perpendicular to the cylindrical axis by means of the Marshall apparatus. This test method is for use with dense graded bituminous mixtures prepared with asphalt cement (modified and unmodified), cutback asphalt, tar, and tar-rubber with maximum size aggregate up to 25 mm (1 in.) in size (passing 25 mm (1 in.) sieve).

1.2 The values stated in SI units are to be regarded as the standard. The values given in parentheses are for information only.

1.3 *This standard does not purport to address all of the safety concerns, if any, associated with its use. It is the responsibility of the user of this standard to establish appropriate safety and health practices and determine the applicability of regulatory limitations prior to use.*

### 2. Referenced Documents

#### 2.1 ASTM Standards:<sup>2</sup>

- C 670** Practice for Preparing Precision and Bias Statements for Test Methods for Construction Materials
- D 1188** Test Method for Bulk Specific Gravity and Density of Compacted Bituminous Mixtures Using Paraffin-Coated Specimens
- D 2726** Test Method for Bulk Specific Gravity and Density of Non-Absorptive Compacted Bituminous Mixtures
- D 3549** Test Method for Thickness or Height of Compacted Bituminous Paving Mixture Specimens
- D 6752** Test Method for Bulk Specific Gravity and Density of Compacted Bituminous Mixtures Using Automatic Vacuum Sealing Method

**D 6926** Practice for Preparation of Bituminous Specimens Using Marshall Apparatus

### 3. Significance and Use

3.1 Marshall stability and flow values along with density; air voids in the total mix, voids in the mineral aggregate, or voids filled with asphalt, or both, filled with asphalt are used for laboratory mix design and evaluation of bituminous mixtures. In addition, Marshall stability and flow can be used to monitor the plant process of producing bituminous mixture. Marshall stability and flow may also be used to relatively evaluate different mixes and the effects of conditioning such as with water.

3.1.1 Marshall stability and flow are bituminous mixture characteristics determined from tests of compacted specimens of a specified geometry. The Marshall Test can be conducted with two different types of equipment: (1) Method A—using a loading frame with a load ring and a dial gauge for deformation or flow meter (Traditional Method) or (2) Method B—using a load-deformation recorder in conjunction with a load cell and linear variable differential transducer (LVDT) or other automatic recording device (Automated Method).

3.1.2 Typically, Marshall stability is the peak resistance load obtained during a constant rate of deformation loading sequence. However, depending on the composition and behavior of the mixture, a less defined type of failure has been observed, as illustrated in Fig. 1. As an alternative method, Marshall stability can also be defined as the load obtained, when the rate of loading increase begins to decrease, such that the curve starts to become horizontal, as shown in the bottom graph of Fig. 1. The magnitude of Marshall Stability varies with aggregate type and grading and bitumen type, grade and amount. Various agencies have criteria for Marshall stability.

3.1.3 Marshall flow is a measure of deformation (elastic plus plastic) of the bituminous mix determined during the stability test. In both types of failure, the Marshall flow is the total sample deformation from the point where the projected tangent of the linear part of the curve intersects the  $x$ -axis (deformation) to the point where the curve starts to become horizontal. As shown in Fig. 1, this latter point usually corresponds to the peak stability; however, as an alternative when the failure condition is not clearly defined, it can be

<sup>1</sup> This test method is under the jurisdiction of ASTM Committee D04 on Road and Paving Materials and is the direct responsibility of Subcommittee D04.20 on Mechanical Tests of Bituminous Mixtures.

Current edition approved June 1, 2005. Published July 2005. Originally approved in 2004. Last previous edition approved in 2004 as D 6927 – 04.

<sup>2</sup> For referenced ASTM standards, visit the ASTM website, www.astm.org, or contact ASTM Customer Service at service@astm.org. For *Annual Book of ASTM Standards* volume information, refer to the standard's Document Summary page on the ASTM website.

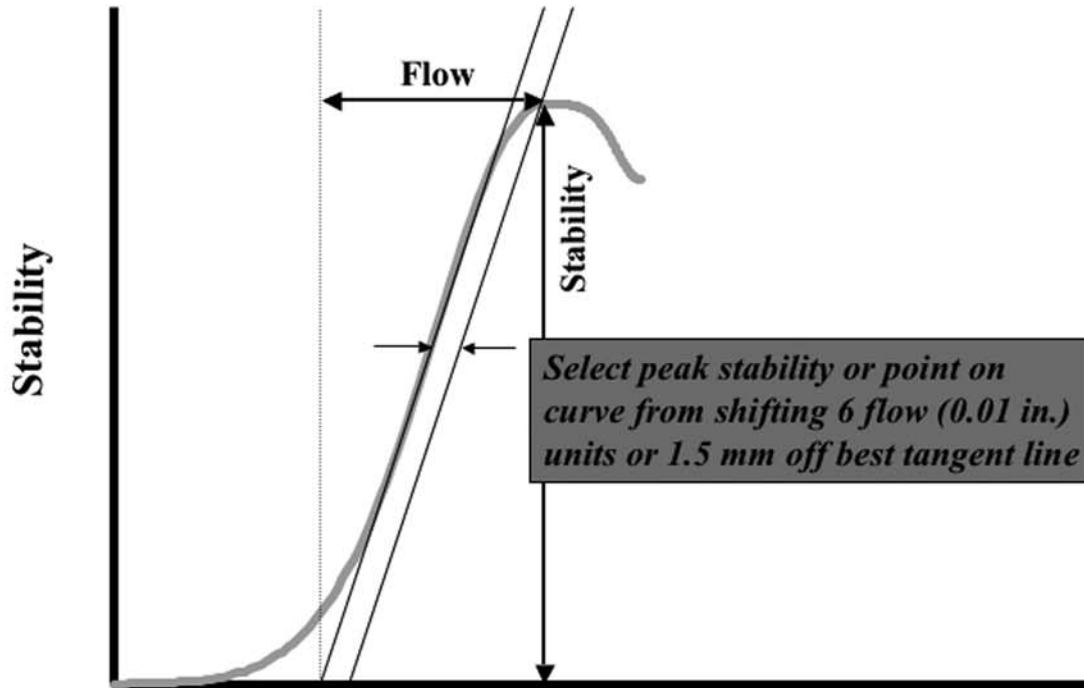

iTech Standards  
(<https://standards.iteh.ai>)  
Document Preview

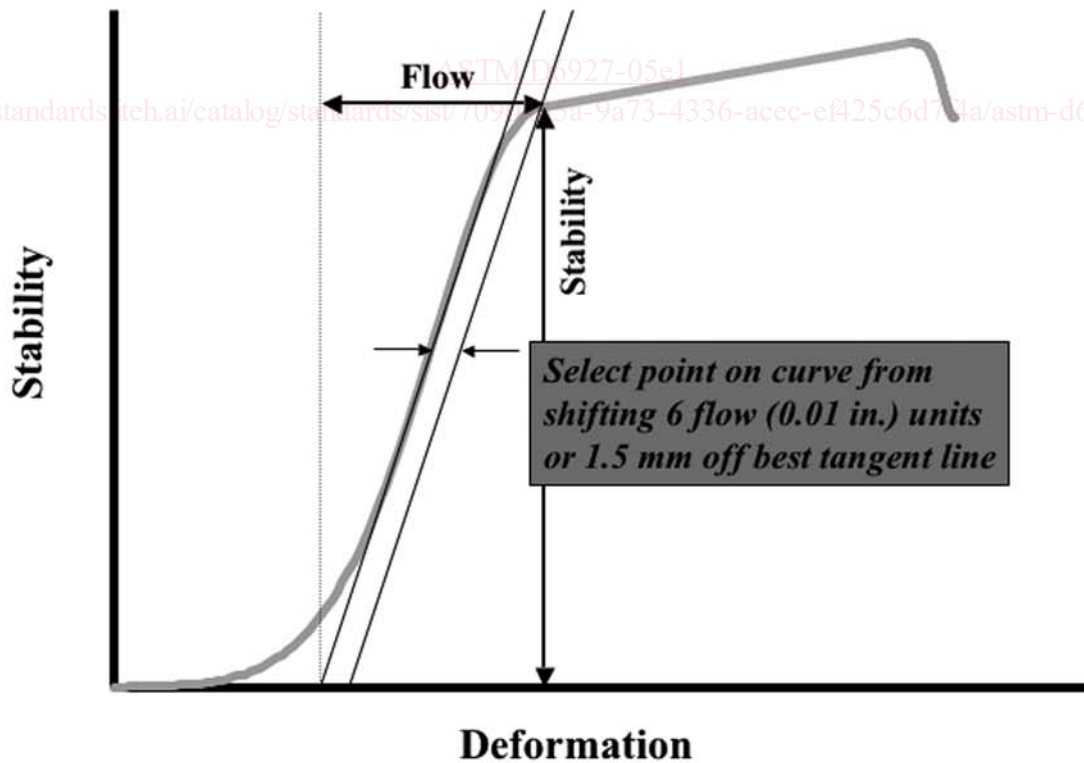

FIG. 1 Flow Determination for Two Types of Specimen Failure

selected as the point on the curve which is six (0.01 in.) flow points (or 1.5 mm) to the right of the tangent line. There is no ideal value but there are acceptable limits. If flow at the selected optimum binder content is above the upper limit, the mix is considered too plastic or unstable and if below the lower limit, it is considered too brittle.

3.1.4 The Marshall stability and flow test results are applicable to dense-graded bituminous mixtures with maximum size aggregate up to 25 mm (1 in.) in size. For the purpose of mix design, Marshall stability and flow test results should consist of the average of a minimum of three specimens at each increment of binder content where the binder content varies in one-half percent increments over a range of binder content. The binder content range is generally selected on the basis of experience and historical testing data of the component materials, but may involve trial and error to include the desirable range of mix properties. Dense-graded mixtures will generally show a peak in stability within the range of binder contents tested. Stability, flow, density, air voids, and voids filled with asphalt binder, may be plotted against binder content to allow selection of an optimum binder content for the mixture. The above test properties may also be weighted differently to reflect a particular mix design philosophy. In addition, a mixture design may be required to meet minimum voids in the mineral aggregate based on nominal maximum aggregate size in the mixture.

3.1.5 Field laboratory Marshall stability and flow tests on specimens made with plant-produced bituminous mix may vary significantly from laboratory design values because of differences in plant mixing versus laboratory mixing. This includes mixing efficiency and aging.

3.1.6 Significant differences in Marshall stability and flow from one set of tests to another or from an average value of several sets of data or specimens, prepared from plant-produced mix may indicate poor sampling, incorrect testing technique, change of grading, change of binder content, or a malfunction in the plant process. The source of the variation should be resolved and the problem corrected.

3.1.7 Specimens will most often be prepared using Practice D 6926 but may be prepared using other types of compaction procedures as long as specimens satisfy geometry requirements. Other types of compaction may cause specimens to have different stress strain characteristics than specimens prepared by Marshall impact compaction. Marshall stability and flow may also be determined using field cores from in situ pavement for information or evaluation. However, these results may not compare with results from laboratory-prepared specimens and shall not be used for specification or acceptance purposes. One source of error in testing field cores arises when the side of the core is not smooth or perpendicular to the core faces. Such conditions can create stress concentrations in loading and low Marshall stability.

## 4. Apparatus

4.1 *Breaking Head*—The testing head (Fig. 2) shall consist of upper and lower cylindrical segments of cast gray or ductile iron, cast steel, or annealed steel tubing. The lower segment shall be mounted on a base having two perpendicular guide rods or posts (minimum 12.5 mm (½ in.) in diameter)

extending upwards. Guide sleeves in the upper segment shall direct the two segments together without appreciable binding or loose motion on the guide rods. A circular testing head with an inside bevel having dimensions other than specified in Fig. 2 has been shown to give results different from the standard testing head.

4.2 *Compression Loading Machine*—The compression loading machine (Fig. 3) may consist of a screw jack mounted in a testing frame and shall be designed to load at a uniform vertical movement of  $50 \pm 5$  mm/min. ( $2.00 \pm 0.15$  in./min). The design in Fig. 3 shows power being supplied by an electric motor. A mechanical or hydraulic compression testing machine may also be used provided the rate of loading can be maintained at  $50 \pm 5$  mm/min ( $2.00 \pm 0.15$  in./min).

4.3 *Load Measuring Device*—As a minimum, a calibrated nominal 20 kN (5000 lb) ring dynamometer (Fig. 3) with a dial indicator to measure ring deflection for applied loads is required. The 20 kN (5000 lb) ring shall have a minimum sensitivity of 50 N (10 lb). The dial indicator should be graduated in increments of 0.0025 mm (0.0001 in.) or finer. The ring dynamometer should be attached to the testing frame (see ring holding bar, Fig. 3) and an adapter (see ring dynamometer adapter, Fig. 3) should be provided to transmit load to the breaking head. The ring dynamometer assembly may be replaced with a load cell connected to a load-deformation recorder or computer provided capacity and sensitivity meet above requirements.

NOTE 1—A higher capacity ring dynamometer may be required for high-stability mixes. These include mixes with harsh, crushed aggregate and dense gradation, as well as mixes made with very stiff binders.

4.4 *Flowmeter*—The Marshall flowmeter consists of a guide sleeve and a gage (Fig. 4). The activating pin of the gage shall slide inside the guide sleeve with minimal friction and the guide sleeve shall slide freely over the guide post (see Fig. 4) of the breaking head. These points of frictional resistance shall be checked before tests. Graduations of the flowmeter gage shall be increments of 0.25 mm (0.01 in.) or finer. Instead of a flowmeter, other devices such as an indicator dial or linear variable differential transducer (LVDT) connected to a load-deformation recorder or computer may be used. These alternate devices should be capable of indicating or displaying flow (deformation) to the required sensitivity. These devices must be designed to measure and record the same relative movement between the top of the guide post and the upper breaking head.

4.5 *Water Bath*—The water bath shall be deep enough to maintain the water level a minimum of 30 mm (1.25 in.) above the top of specimens. The bath shall be thermostatically controlled so as to maintain the specified test temperature  $\pm 1^\circ\text{C}$  ( $2^\circ\text{F}$ ) at any point in the tank. The tank shall have a perforated false bottom or be equipped with a shelf for supporting specimens 50 mm (2 in.) above the bottom of the bath and be equipped with a mechanical water circulator.

4.6 *Oven*—An oven capable of maintaining the specified test temperature  $\pm 1^\circ\text{C}$  ( $2^\circ\text{F}$ ).

4.7 *Air Bath*—The air bath for mixtures containing cutback asphalt binder shall be thermostatically controlled and shall maintain the air temperature at  $25 \pm 1^\circ\text{C}$  ( $77 \pm 2^\circ\text{F}$ ).

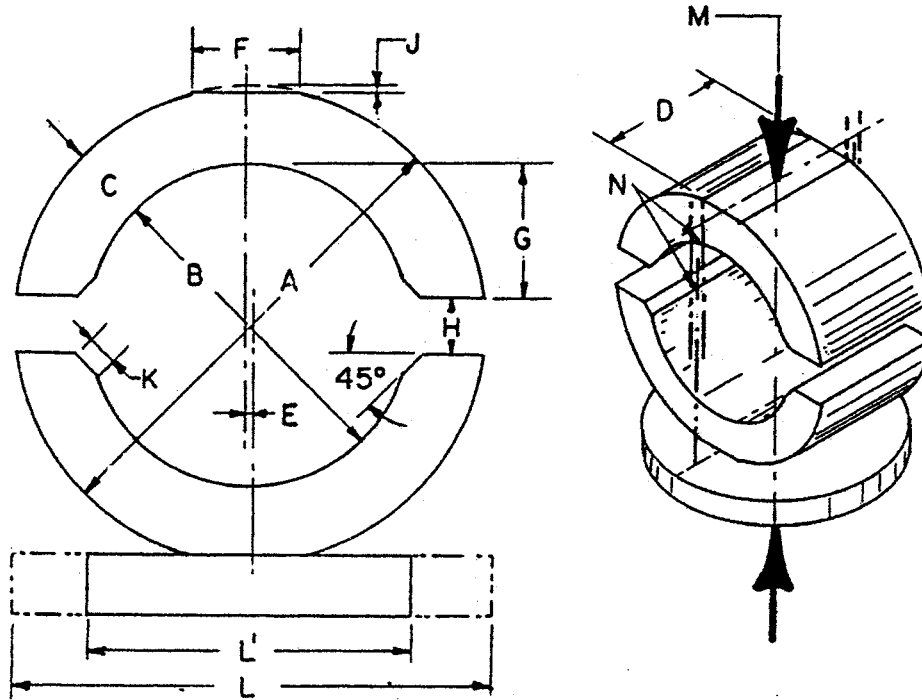

	mm	in.
A	148.6 to 149.2	5.850 to 5.875
B	101.6 to 101.7	4.000 to 4.005
C	23.4 to 23.7	0.923 to 0.935
D	76.2 to 76.5	3.000 to 3.010
E	0.0 to 0.05	0.000 to 0.002
F	34.8 to 35.1	1.370 to 1.380
G	41.28 to 41.33	1.625 to 1.627
H	19.0 to 19.1	0.748 to 0.752
J	2.03 to 2.13	0.080 to 0.084
K	8.9 to 9.1	0.350 to 0.358
L'	101.5 to 101.7	3.995 to 4.005
L	152.3 to 152.5	5.995 to 6.005
M	Stresses transmitted through one spherical and one flat surface.	
N	Geometry of guide system optional but must be appreciably free of both play and binding. One test for binding is to lift or lower head by a single guide bushing.	

FIG. 2 Testing Head Dimensions

4.8 *Thermometers*—Calibrated thermometers for water and air baths shall cover the temperature range specified and be readable to 0.2°C (0.4°F).

5. Procedure

5.1 A minimum of three specimens of a given mixture shall be tested. The specimens should have the same aggregate type, quality, and grading; the same mineral filler type and quantity; and the same binder source, grade and amount. In addition, the specimens should have the same preparation, that is, temperatures, cooling, and compaction.

5.2 Specimens should be cooled to room temperature after compaction. During cooling they should be placed on a smooth, flat surface. Bulk specific gravity of each specimen shall be determined by Test Methods D 2726, D 1188, or D 6752. The bulk specific gravities of replicate specimens for each binder content shall agree within ±0.020 of the mean as noted in Practice D 6926.

5.2.1 Measure specimen thickness according to Test Method D 3549.

5.3 Specimens can be conditioned for testing as soon as they reach ambient room temperature. Testing shall be completed within 24 h after compaction. Bring specimens prepared with asphalt cement, tar, or tar-rubber to the specified temperature by immersion in the water bath 30 to 40 min, or placement in the oven for 120 to 130 min. Maintain the bath or oven temperature at 60 ± 1°C (140 ± 2°F) for asphalt cement, 49 ± 1°C (120 ± 2°F) for tar-rubber specimens, and 38 ± 1°C (100 ± 2°F) for tar specimens. Bring specimens prepared with cutback asphalt to temperature by placing them in the air bath for 120 to 130 min. Maintain the air bath temperature at 25 ± 1°C (77 ± 2°F).

NOTE 2—Temperature variation will affect test results. A dummy specimen with a thermocouple can be used to monitor temperature.

5.3.1 Thoroughly clean the guide rods and inside surfaces of the test head segments prior to conducting the test. Lubricate guide rods so that the upper test head segment slides freely over them. The testing head shall be at a temperature of 20 to