



Designation: D 2860/D 2860M – 90 (Reapproved 1999)

Standard Test Method for Adhesion of Pressure-Sensitive Tape to Fiberboard at 90° Angle and Constant Stress¹

This standard is issued under the fixed designation D 2860/D 2860M; the number immediately following the designation indicates the year of original adoption or, in the case of revision, the year of last revision. A number in parentheses indicates the year of last reapproval. A superscript epsilon (ϵ) indicates an editorial change since the last revision or reapproval.

This standard has been approved for use by agencies of the Department of Defense.

1. Scope

1.1 This test method covers the determination of the property of adhesion of pressure-sensitive tape to a fiber-board surface. The user of this test method has the option of choosing the paper surface for the test. The test surface may be the standard linerboard, another linerboard (or paper) of individual interest, or a specific fiberboard.

1.2 The values stated in either SI or inch-pound units are to be regarded separately as standard. The values stated in each system are not exact equivalents; therefore, each system must be used independently, without combining values in any way.

1.3 *This standard does not purport to address all of the safety concerns, if any, associated with its use. It is the responsibility of the user of this standard to establish appropriate safety and health practices and determine the applicability of regulatory limitations prior to use.*

2. Referenced Documents

2.1 ASTM Standards:

- D 996 Terminology of Packaging and Distribution Environments²
- D 2904 Practice for Interlaboratory Testing of a Textile Test Method that Produces Normally Distributed Data³
- D 2906 Practice for Statements on Precision and Bias for Textiles³
- D 3715/D3715M Practice for Quality Assurance of Pressure-Sensitive Tapes²
- D 4332 Practice for Conditioning Containers, Packages, or Packaging Components for Testing²

3. Terminology

3.1 *Definitions:* Terminology found in Terminology D 996 shall apply.

¹ This test method is under the jurisdiction of ASTM Committee D-10 on Packaging, and is the direct responsibility of Subcommittee D 10.14 on Tape and Labels.

Current edition approved June 29, 1990. Published August 1990. Originally published as D 2860 – 70. Last previous edition D 2860 – 87.

² *Annual Book of ASTM Standards*, Vol 15.09.

³ *Annual Book of ASTM Standards*, Vol 07.01.

4. Summary of Test Method

4.1 *Procedure A*—The pressure-sensitive tape is mounted on a rigid panel. The adhesive side is exposed. A strip of linerboard, which represents the fiberboard, is placed against the tape adhesive with controlled pressure. The area of contact is specified. The panel is mounted in a horizontal position. A specified mass is fastened to one end of the linerboard. The mass acts to peel the linerboard away from the adhesive at an angle of 90°. The time required to peel the linerboard from the tape is measured.

4.2 *Procedure B*—In this procedure, the fiberboard or the linerboard representing it is adhered to a rigid panel and the tape peeled from it. In all other respects, the procedure is the same as Procedure A.

5. Significance and Use

5.1 This test method is designed to show the adhesion of a pressure-sensitive tape to fiberboard when the tape is under a constant stress. Test data from this test method for some types of packaging tape relates to tape performance on fiberboard box closure.

5.2 Procedure A should be used when comparing tapes to an established requirement. The requirement may be established using either the standard linerboard or another linerboard representing a specific fiberboard.

5.3 Procedure B should be used to rank tapes as to their ability to adhere to fiberboard.

6. Apparatus and Materials

6.1 *Tape*, pressure-sensitive, double-coated, 48-mm [2-in.] width. The tape shall exhibit sufficient adhesion to the panel and test specimen or fiberboard to avoid the failures cited in 10.1.9 and 10.2.14.

6.2 *Panel*—Any steel piece at least 50 by 125 mm [2 by 5 in.] and no less than 1.1 mm [0.043 in.] thick, having one face (2 by 5 in.) that does not deviate from a plane by more than 0.050 mm [0.002 in.].

6.3 *Stop Watch*.

6.4 *Razor Blade*, single-edge.

6.5 *Mask*—Any paper no more than 0.050 mm [0.002 in.] thick formed to a rectangle approximately 125 by 60 mm [5 by 2.5 in.] with a rectangular hole exactly 24 ± 0.25 [1.0 ± 0.01] by 32 mm [1.25 in.] centered in the piece. The 24-mm [1-in.] hole dimension shall be in the 125-mm [5-in.] direction (see Fig. 1 and Fig. 2).

6.6 *Cutter*, for preparing fiberboard or linerboard and tape specimens.

6.7 *Paperboard Piece*, approximately 25 by 25 mm [1 by 1 in.], for reinforcement.

6.8 *Paper Punch*, single-hole.

6.9 *Fiberboard or Linerboard Surface*,⁴ against which the test is made.

6.9.1 For Procedure A, cut a rectangle exactly 24 ± 0.25 mm [1.0 ± 0.01 in.] wide by at least 125 mm [5 in.] in length, from the linerboard representing the fiberboard on which the tape will be used. The long dimension shall lie at a right angle to the machine direction of the linerboard. Reinforce one end of the strip with a chipboard piece adhered with double-coated tape. Punch a hole at the center of the reinforcement.

6.9.2 For Procedure B, cut a rectangle, preferably 125 by 50 mm [5 by 2 in.], but no less than 50 by 50 mm [2 by 2 in.], from the fiberboard on which the tape will be used (or linerboard representing it). The long test dimension shall lie at a right angle to the machine direction of the linerboard.

6.9.3 For either procedure, prepare the linerboard or fiberboard in advance of testing and mark it to show which side to

use. When comparing one roll of tape to another or one lot of tape to another, the linerboard or fiberboard should be from a single lot.

6.10 *Steel Roller*, 82.5 ± 2.5 mm [3.25 ± 0.1 in.] in diameter and 45 ± 1.5 mm [1.75 ± 0.05 in.] in width, covered with rubber approximately 6 mm [0.25 in.] in thickness having a Shore A durometer hardness of 80 ± 5 . The surface shall be a true cylinder void of any convex or concave deviations. The mass of the roller shall be 2040 ± 45 g [4.5 ± 0.1 lb]. The mass of the handle shall not add to the mass of the roller during use.

NOTE 1—A simple check to determine if the rubber surface is cylindrical is to wrap the roller in a very thin paper (onionskin) and drag it across a flat glass plate on which is placed a carbon paper, face up. The carbon rubs off onto the thin paper wrapper to reveal high spots or hollows on the rubber surface.

6.11 *Test Stand*, to support the panel securely in a horizontal plane during the test period.

6.12 *Mass*, 200 ± 0.2 g, with a hook.

6.13 *Timing System*, for measuring test time in minutes.

6.14 *Paper*, clean, unprinted, and without a coating of any kind, for use in adhering linerboard or fiberboard to the panel (Procedure B).

7. Sampling

7.1 Sampling shall be in accordance with Practice D 3715.

8. Test Specimens

8.1 A roll or rolls of tape for testing must be at least 36 mm [1.5 in.] in width.

⁴The linerboard accepted as the standard test surface, Standard Reference Material 1810A, is available from the Office of Standard Reference Materials, National Institute of Standards and Technology, Washington, DC 20234.

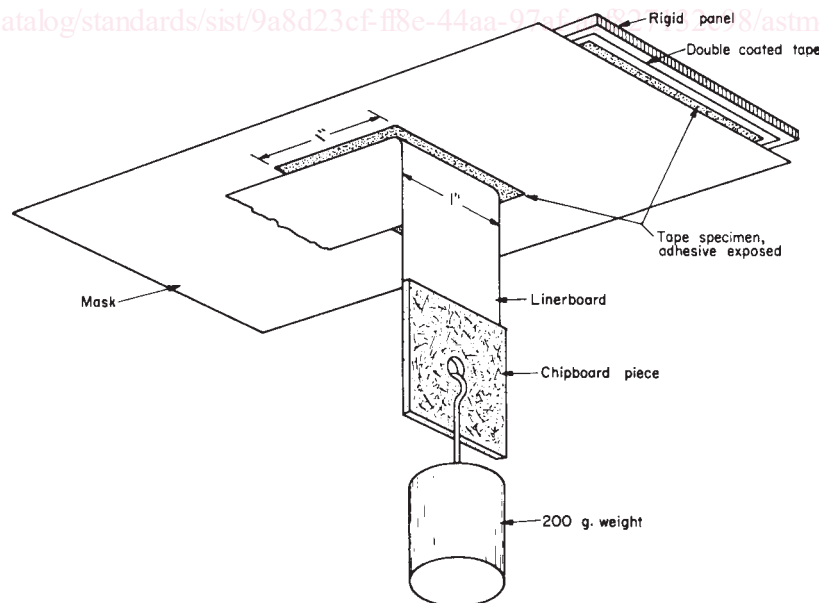

NOTE 1—Fix panel securely in a horizontal plane.

FIG. 1 Test Assembly for Procedure A