



Designation: D2717 – 95 (Reapproved 2005)

Standard Test Method for Thermal Conductivity of Liquids¹

This standard is issued under the fixed designation D2717; the number immediately following the designation indicates the year of original adoption or, in the case of revision, the year of last revision. A number in parentheses indicates the year of last reapproval. A superscript epsilon (ϵ) indicates an editorial change since the last revision or reapproval.

1. Scope

1.1 This test method covers the determination of the thermal conductivity of nonmetallic liquids. It is applicable to liquids that are: (1) chemically compatible with borosilicate glass and platinum; (2) moderately transparent or absorbent to infrared radiation; and (3) have a vapor pressure less than 200 torr at the temperature of test.

1.1.1 Materials that have vapor pressures of up to 345 kPa (50 psia), absolute can be tested provided that adequate measures are taken to repress volatilization of the sample by pressurizing the thermal conductivity cell. The usual safety precautions for pressure vessels shall be followed under these circumstances.

1.2 The values stated in SI units are to be regarded as standard. No other units of measurement are included in this standard.

1.3 *This standard does not purport to address all of the safety concerns, if any, associated with its use. It is the responsibility of the user of this standard to establish appropriate safety and health practices and determine the applicability of regulatory limitations prior to use.*

2. Referenced Documents

2.1 ASTM Standards:²

[D86 Test Method for Distillation of Petroleum Products at Atmospheric Pressure](#)

[D1160 Test Method for Distillation of Petroleum Products at Reduced Pressure](#)

[D2887 Test Method for Boiling Range Distribution of Petroleum Fractions by Gas Chromatography](#)

[D2893 Test Methods for Oxidation Characteristics of Extreme-Pressure Lubrication Oils](#)

3. Terminology

3.1 Units:

¹ This test method is under the jurisdiction of ASTM Committee D02 on Petroleum Products and Lubricants and is the direct responsibility of Subcommittee D02.11 on Engineering Sciences of High Performance Fluids and Solids.

Current edition approved June 1, 2005. Published September 2005. Originally approved in 1968. Last previous edition approved in 2000 as D2717-95(2000). DOI: 10.1520/D2717-95R05.

² For referenced ASTM standards, visit the ASTM website, www.astm.org, or contact ASTM Customer Service at service@astm.org. For *Annual Book of ASTM Standards* volume information, refer to the standard's Document Summary page on the ASTM website.

TABLE 1 Selected Conversion Factors for Thermal Conductivity

To Convert From	To	Multiply By
cal/s·cm·°C	w/cm·°C	4.184
cal/s·cm·°C	kcal/h·m·°C	360
cal/s·cm·°C	Btu·in./h·ft ² ·°F	2903
w/cm·°C	cal/s·cm·°C	0.2389
w/cm·°C	kcal/h·m·°C	86.00
w/cm·°C	Btu·in./h·ft ² ·°F	693.7
kcal/h·m·°C	cal/s·cm·°C	0.002778
kcal/h·m·°C	W/cm·°C	0.01163
kcal/h·m·°C	Btu·in./h·ft ² ·°F	8.064
Btu·in./h·ft ² ·°F	cal/s·cm·°C	0.0003445
Btu·in./h·ft ² ·°F	W/cm·°C	0.001442
Btu·in./h·ft ² ·°F	kcal/h·m·°C	0.1240

3.1.1 The energy units used in this test method are defined as follows:

1 Cal (International Table calorie) = 4.1868 absolute J

1 Btu (British thermal unit) = 1055.07 absolute J

3.1.2 The units of thermal conductivity commonly used and their interconversion factors are shown in Table 1.

3.2 For working purposes in this test method, the rounded-off value of 4.19 J/cal is used, as this is adequate for the precision of the test and also represents the rounded-off value of watt-second per calorie units in Table 1, thus avoiding the difficulty caused by the dual definition of the calorie.

3.3 Symbols:

T_f = filament temperature, °C,
 T_b = bath thermostat temperature, °C,
 ΔT = $T_f - T_b$, °C,
 r_f = filament radius, cm,
 r_i = internal radius of tube, cm,
 r_o = external radius of tube, cm,
 L = effective length of tube, cm,
 R = resistance of filament, Ω ,
 I = electric current through filament, A,
 K_L = thermal conductivity of liquid, cal/s·cm·°C,
 K_G = thermal conductivity of glass-tube, cal/s·cm·°C,
 A = $[\ln(r_i/r_f)]/2\pi L$, cm⁻¹, and
 B = $[\ln(r_o/r_i)]/2\pi L K_G$, s²/cal·cm.

4. Summary of Test Method

4.1 A thermal conductivity cell consisting of a straight, four-lead, platinum resistance thermometer element located concentrically in a long, small-diameter, precision-bore borosilicate glass tube is calibrated by accurate measurement of the

cell dimensions and by determination of the temperature-resistance properties of the platinum element.

4.2 Thermal conductivity is determined by measurement of the temperature gradient produced across the liquid sample by a known amount of energy introduced into the cell by electrically heating the platinum element.

5. Significance and Use

5.1 The thermal conductivity of a substance is a measure of the ability of that substance to transfer energy as heat in the absence of mass transport phenomena. It is used in engineering calculations that relate to the manner in which a given system can react to thermal stresses.

6. Apparatus

6.1 *Thermal Conductivity Cell*, consists essentially of a thin, straight platinum filament sealed axially in a borosilicate glass tube. The filament is held taut by a platinum spring. Two heavy gage platinum studs support the filament at either end and permit the filament itself to serve as the element and a four-lead platinum resistance thermometer. Details and cell construction are shown in Fig. 1.

6.1.1 A tube of 5.00 ± 0.01 mm inside diameter shall be used for liquids of low viscosity as these may create thermal convection problems in the 10.47-mm tube.

6.2 *Temperature Conditioning Bath*, capable of maintaining temperature in the vicinity of the thermal conductivity cell constant and uniform to within $\pm 0.001^\circ\text{C}$ at the test temperature.

6.3 *Resistance Measuring Device*, capable of measuring up to 50Ω with a sensitivity of at least $10^{-4}\Omega$. A Mueller bridge assembly with commutator for 4-lead resistance thermometer service or digital multimeter with equivalent sensitivity and a minimum of six digit resistance resolution with 4-lead measurement capability are acceptable.

6.4 *Potential Measuring Device*, capable of measuring up to 1 V with a precision of 10^{-6} V or a potentiometer assembly with sensitivity of at least 1 μV or a digital multimeter with equivalent sensitivity, range, and a minimum of six digit resolution is acceptable.

6.5 *Resistor*, 1- Ω , precision type, with accuracy of $\pm 0.0005\%$ and stability of $\pm 0.001\%$ per year.^{3,4}

6.6 *Platinum Resistance Thermometer* 4-lead long stem with quartz sheath.

6.7 *Power Supply*, 24-V dc.

NOTE 1—Two 12-V automobile batteries in series have proved satisfactory as a power supply. They should be relatively new and fully charged.

6.8 *Power Supply*, constant-voltage, for potentiometer.^{4,5}

³ The sole source of supply of Model 9330/1 known to the committee at this time is Guildline Instruments, Inc., 103 Commerce St., Ste. 160, P. O. Box 952590, Lake Mary, FL 32795-2590.

⁴ If you are aware of alternative suppliers, please provide this information to ASTM International Headquarters. Your comments will receive careful consideration at a meeting of the responsible technical committee,¹ which you may attend.

⁵ The sole source of supply of No. 245G-NW-19 known to the committee at this time is Instrulab, Inc., Dayton, OH.

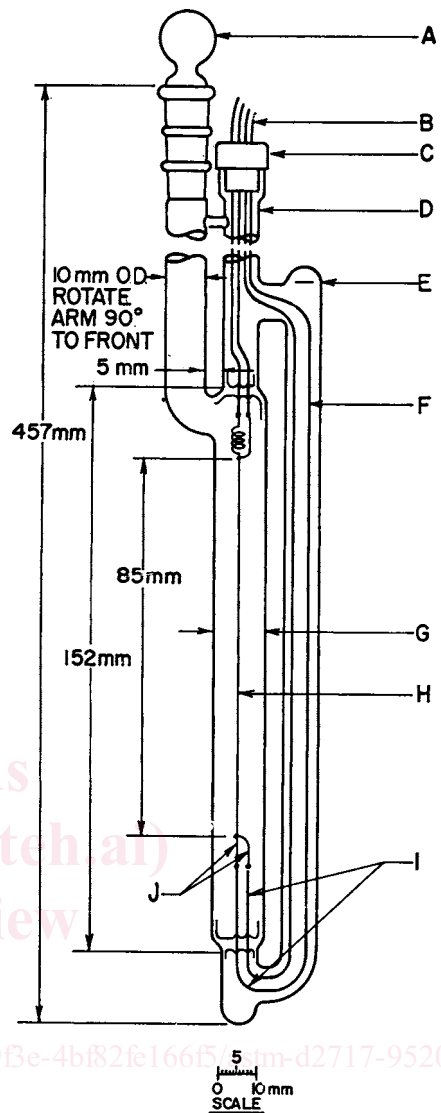

- A. Penny Head Stopper standard taper 10/30.
- B. Gold leads to extend 24 in. beyond PTFE plug. Leads from top and bottom contacts to be of equal length. Excess from top leads to be located in side tube rather than in the top extension of the cell.
- C. PTFE plug drilled for wires.
- D. 9-mm OD borosilicate glass.
- E. Fill top and side tubes with 350 to 500-cSt silicon oil to this level.
- F. Insulate gold wire in top and side tubes with woven glass.
- G. 10.744 ± 0.0127 mm ID precision bore borosilicate glass tubing.
- H. 0.0584-mm dia platinum wire.
- I. Use 0.502 mm platinum through glass but add 0.502 mm gold for long leads.
- J. 0.203-mm diameter platinum.

FIG. 1 Details of Thermal Conductivity Cell

6.9 *Standard Cell*, unsaturated cadmium type, for potentiometer.^{4,6}

6.10 *Switches*, low thermal emf, knife or rotary.

⁶ The sole source of supply of a cell of this type known to the committee at this time is Epply Laboratory, Inc., Newport, RI.