



SLOVENSKI STANDARD

SIST EN 755-7:1999

01-november-1999

Aluminij in aluminijeve zlitine - Iztiskane palice, drogovi, cevi in profili - 7. del: Nevarjene (narejene iz celega) cevi, odstopki mer in tolerance oblik

Aluminium and aluminium alloys - Extruded rod/bar, tube and profiles - Part 7: Seamless tubes, tolerances on dimensions and form

Aluminium und Aluminiumlegierungen - Stranggepreßte Stangen, Rohre und Profile - Teil 7: Nahtlose Rohre, Grenzabmaße und Formtoleranzen

Aluminium et alliages d'aluminium - Barres, tubes et profilés filés - Partie 7: Tubes filés sur aiguille, tolérances sur dimensions et forme

<https://standards.iteh.ai/catalog/standards/sist/d697667e-92a4-4a94-a0b8-d8f2cf9e6b0f/sist-en-755-7-1999>

Ta slovenski standard je istoveten z: EN 755-7:1998

ICS:

77.150.10 Aluminijski izdelki Aluminium products

SIST EN 755-7:1999 en

iTeh STANDARD PREVIEW
(standards.iteh.ai)

SIST EN 755-7:1999

<https://standards.iteh.ai/catalog/standards/sist/d697667e-92a4-4a94-a0b8-d8f2cf9e6b0f/sist-en-755-7-1999>

ICS 77.150.10

Descriptors: aluminium, aluminium alloys, extruded products, aluminium tubes, tolerances on dimension, tolerances on form

English version

Aluminium and aluminium alloys - Extruded rod/bar, tube and profiles - Part 7: Seamless tubes, tolerances on dimensions and form

Aluminium et alliages d'aluminium - Barres, tubes et profilés filés - Partie 7: Tubes filés sur aiguille, tolérances sur dimensions et forme

Aluminium und Aluminiumlegierungen - Stranggepreßte Stangen, Rohre und Profile - Teil 7: Nahtlose Rohre, Grenzabmaße und Formtoleranzen

This European Standard was approved by CEN on 1 July 1998.

CEN members are bound to comply with the CEN/GENELEC Internal Regulations which stipulate the conditions for giving this European Standard the status of a national standard without any alteration. Up-to-date lists and bibliographical references concerning such national standards may be obtained on application to the Central Secretariat or to any CEN member.

This European Standard exists in three official versions (English, French, German). A version in any other language made by translation under the responsibility of a CEN member into its own language and notified to the Central Secretariat has the same status as the official versions.

CEN members are the national standards bodies of Austria, Belgium, Czech Republic, Denmark, Finland, France, Germany, Greece, Iceland, Ireland, Italy, Luxembourg, Netherlands, Norway, Portugal, Spain, Sweden, Switzerland and United Kingdom.

iTeh STANDARD PREVIEW
(standards.iteh.ai)

SIST EN 755-7:1998

<https://standards.iteh.ai/catalog/standards/sist/d6976674-92a4-4a94-a0b8-d8f2cf9e6b0f/sist-en-755-7-1998>



EUROPEAN COMMITTEE FOR STANDARDIZATION
COMITÉ EUROPÉEN DE NORMALISATION
EUROPÄISCHES KOMITEE FÜR NORMUNG

Central Secretariat: rue de Stassart, 36 B-1050 Brussels

Contents

	Page
Foreword	3
1 Scope	4
2 Alloy groups	4
3 Tolerances on dimensions	5
3.1 General.....	5
3.2 Diameter - Round tube.....	5
3.3 Width, depth or width across flats - squares, rectangles, hexagons, octagons	6
3.4 Wall thickness.....	7
3.5 Length.....	8
3.6 Squareness of cut ends	9
4 Tolerances on form	9
4.1 General.....	9
4.2 Straightness.....	9
4.3 Convexity - Concavity	10
4.4 Twist	11
4.5 Angularity.....	12
4.6 Corner and fillet radii.....	13
4.7 Depth of dents for round tube	14

iTeh STANDARD PREVIEW (standards.iteh.ai)

[SIST EN 755-7:1999](https://standards.iteh.ai/catalog/standards/sist/d697667e-92a4-4a94-a0b8-d8f2c19e6b0f/sist-en-755-7-1999)

<https://standards.iteh.ai/catalog/standards/sist/d697667e-92a4-4a94-a0b8-d8f2c19e6b0f/sist-en-755-7-1999>



Foreword

This European Standard has been prepared by Technical Committee CEN/TC 132 "Aluminium and aluminium alloys", the secretariat of which is held by AFNOR.

This European Standard shall be given the status of a national standard, either by publication of an identical text or by endorsement, at the latest by January 1999, and conflicting national standards shall be withdrawn at the latest by January 1999.

According to the CEN/CENELEC Internal Regulations, the national standards organizations of the following countries are bound to implement this European Standard: Austria, Belgium, Czech Republic, Denmark, Finland, France, Germany, Greece, Iceland, Ireland, Italy, Luxembourg, Netherlands, Norway, Portugal, Spain, Sweden, Switzerland and the United Kingdom.

Within its programme of work, Technical Committee CEN/TC 132 entrusted CEN/TC 132/WG 5 "Extruded and drawn products" to prepare the following standard :

EN 755-7 Aluminium and aluminium alloys - Extruded rod/bar, tube and profiles -
Part 7 : Seamless tubes, tolerances on dimensions and form

This standard is part of a series of nine standards. The other standards deal with :

EN 755-1 Aluminium and aluminium alloys - Extruded rod/bar, tube and profiles -
Part 1 : Technical conditions for inspection and delivery

EN 755-2 Aluminium and aluminium alloys - Extruded rod/bar, tube and profiles -
Part 2 : Mechanical properties

EN 755-3 Aluminium and aluminium alloys - Extruded rod/bar, tube and profiles -
Part 3 : Round bars, tolerances on dimensions and form

EN 755-4 Aluminium and aluminium alloys - Extruded rod/bar, tube and profiles -
Part 4 : Square bars, tolerances on dimensions and form

EN 755-5 Aluminium and aluminium alloys - Extruded rod/bar, tube and profiles -
Part 5 : Rectangular bars, tolerances on dimensions and form

EN 755-6 Aluminium and aluminium alloys - Extruded rod/bar, tube and profiles -
Part 6 : Hexagonal bars, tolerances on dimensions and form

EN 755-8 Aluminium and aluminium alloys - Extruded rod/bar, tube and profiles -
Part 8 : Porthole tubes, tolerances on dimensions and form

EN 755-9 Aluminium and aluminium alloys - Extruded rod/bar, tube and profiles -
Part 9 : Profiles, tolerances on dimensions and form

STANDARD PREVIEW
(standards.iteh.ai)
SIST EN 755-7:1998
<https://standards.iteh.ai/catalog/standards/sist/d697667e-92a4-4a94-a0b8-d82cf9e6b0f/sist-en-755-7-1998>

1 Scope

This part of EN 755 specifies the tolerances on dimensions and form for aluminium and aluminium alloy extruded seamless tubes with an outside diameter (OD) from 8 mm to 450 mm (round tube, see figure 1) or with a cross section contained within a circumscribing circle (CD) from 10 mm to 350 mm (other than round tube, see figure 2), supplied in straight lengths.

This standard only applies to tube produced by the seamless die/mandrel method of extrusion.

This standard applies to extruded seamless tube for general engineering applications only.

This standard does not apply to extruded tube produced by tube porthole/bridge method or coiled tube.

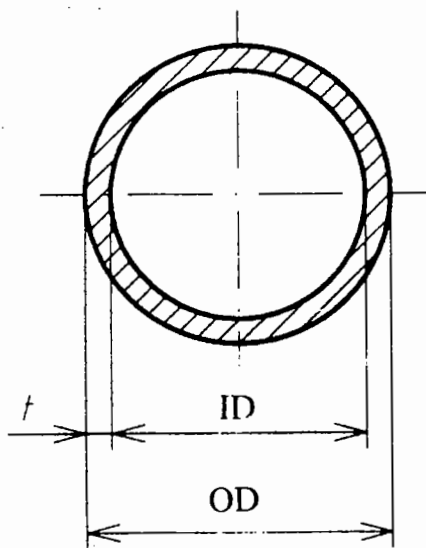

Figure 1 : Round tube

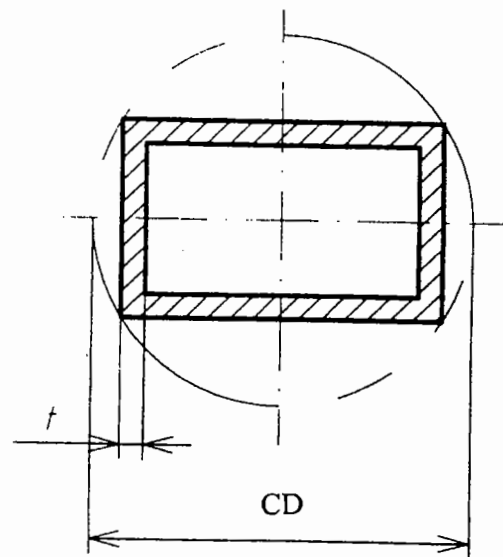

Figure 2 : Circumscribing circle for other than round tube

2 Alloy groups

For the purposes of this European Standard, the alloys are distributed into two groups which corresponds to varying degrees of difficulty when manufacturing the products.

The division into group I and group II of the most commonly used general engineering alloys is specified in table 1. Grouping of other alloys is subject to agreement between purchaser and supplier.

Table 1 : Alloy groups

Group I	<p>EN AW-1050A, EN AW-1070A, EN AW-1200, EN AW-1350</p> <p>EN AW-3003, EN AW-3103</p> <p>EN AW-5005, EN AW-5005A</p> <p>EN AW-6101A, EN AW-6101B, EN AW-6005, EN AW-6005A, EN AW-6106, EN AW-6060, EN AW-6063, EN AW-6063A, EN AW-6463</p>
Group II	<p>EN AW-2007, EN AW-2011, EN AW-2011A, EN AW-2014, EN AW-2014A, EN AW-2017A, EN AW-2024, EN AW-2030</p> <p>EN AW-5019 ¹⁾, EN AW-5051A, EN AW-5251, EN AW-5052, EN AW-5154A, EN AW-5454, EN AW-5754, EN AW-5083, EN AW-5086</p> <p>EN AW-6012, EN AW-6018, EN AW 6351, EN AW 6061, EN AW 6261, EN AW-6262, EN AW-6081, EN AW-6082</p> <p>EN AW-7003, EN AW-7005, EN AW-7020, EN AW-7022, EN AW-7049A, EN AW-7075</p>
<p>1) EN AW-5019 is the new designation for EN AW-5056A.</p>	

3 Tolerances on dimensions

3.1 General

When outside diameter *OD*, inside diameter *ID*, and wall thickness *t*, (or their equivalent dimensions in other than round tube) are all specified, standard tolerances shall apply to any two of these dimensions, but not to all three. As a result, the purchaser shall only state two nominal dimensions on any given order.

3.2 Diameter - Round tube

Mean diameter is defined as the average of two diameter measurements taken at right angles to each other at any point along the length.

The tolerances on diameter are specified in table 2.

<https://standards.iteh.ai/catalog/standards/sist/d697667e-92a4-4a94-a0b8-d8f2cf9e6b0f/sist-en-755-7-1999>

Table 2 : Tolerances on diameter for round tube

Dimensions in millimetres

Diameter (OD or ID)		Tolerance on diameter			
		Maximum allowable deviation of mean diameter from specified diameter ⁶⁾	Maximum allowable deviation of diameter at any point from specified diameter ¹⁾		
Over	Up to and including		non-annealed and non heat treated tube ²⁾	heat treated tube ³⁾	annealed tube ⁴⁾
≥ 8	18	± 0,25 ⁵⁾	± 0,40 ⁵⁾	± 0,60 ⁵⁾	± 1,5 ⁵⁾
18	30	± 0,30	± 0,50	± 0,70	± 1,8
30	50	± 0,35	± 0,60	± 0,90	± 2,2
50	80	± 0,40	± 0,70	± 1,1	± 2,6
80	120	± 0,60	± 0,90	± 1,4	± 3,6
120	200	± 0,90	± 1,4	± 2,0	± 5,0
200	350	± 1,4	± 1,9	± 3,0	± 7,6
350	450	± 1,9	± 2,8	± 4,0	± 10,0

1) Not applicable to tubes having a wall thickness less than 2,5 % of the specified outside diameter. The tolerance for tubes with wall thickness less than 2,5 % of the specified outside diameter shall be determined by multiplying the applicable tolerance as follows :

- wall thickness over 2,0 % up to and including 2,5 % of outside diameter : 1,5 x tolerance ;
- wall thickness over 1,5 % up to and including 2,0 % of outside diameter : 2,0 x tolerance ;
- wall thickness over 1,0 % up to and including 1,5 % of outside diameter : 3,0 x tolerance ;
- wall thickness over 0,5 % up to and including 1,0 % of outside diameter : 4,0 x tolerance.

2) Applies to all alloys in F or H112 tempers.

3) Applies to all alloys in T4, T5, T6, T64, T66 and Tx511 tempers.

4) Applies to all alloys in O, H111 and Tx510 tempers.

5) This tolerance applies for outside diameter only, i.e. tube in this size range can only be specified as "Outside Diameter x Wall Thickness".

6) Not applicable to Tx510 or Tx511 tempers.

3.3 Width, depth or width across flats - squares, rectangles, hexagons, octagons

The tolerances on width, (depth or width across flats) are specified in table 3.

SIST EN 755-7:1999

<https://standards.iteh.ai/catalog/standards/sist/d697667e-92a4-4a94-a0b8-d8f2cf9e6b0f/sist-en-755-7-1999>

Table 3 : Tolerances on width, depth or width across flats

Dimensions in millimetres

Width, depth or width across flats		Tolerances on width, depth or width across flats 1) 2)							
		$CD \leq 100$		$100 < CD \leq 200$		$200 < CD \leq 300$		$300 < CD \leq 350$	
Over	Up to and including	Alloy group I	Alloy group II	Alloy group I	Alloy group II	Alloy group I	Alloy group II	Alloy group I	Alloy group II
-	10	± 0,25	± 0,40	± 0,30	± 0,50	± 0,35	± 0,55	± 0,40	± 0,60
10	25	± 0,30	± 0,50	± 0,40	± 0,70	± 0,50	± 0,80	± 0,60	± 0,90
25	50	± 0,50	± 0,80	± 0,60	± 0,90	± 0,80	± 1,0	± 0,90	± 1,2
50	100	± 0,70	± 1,0	± 0,90	± 1,2	± 1,1	± 1,3	± 1,3	± 1,6
100	150	-	-	± 1,1	± 1,5	± 1,3	± 1,7	± 1,5	± 1,8
150	200	-	-	± 1,3	± 1,9	± 1,5	± 2,2	± 1,8	± 2,4
200	300	-	-	-	-	± 1,7	± 2,5	± 2,1	± 2,8
300	350	-	-	-	-	-	-	± 2,8	± 3,5

1) Not applicable to tubes having a wall thickness less than 2,5 % of the specified outside width, depth or width across flats. The tolerance for tubes with wall thickness less than 2,5 % of the specified width, depth or width across flats shall be determined by multiplying the applicable tolerance as follows :

- wall thickness over 2,0 % up to and including 2,5 % of outside parameter : 1,5 x tolerance ;
- wall thickness over 1,5 % up to and including 2,0 % of outside parameter : 2,0 x tolerance ;
- wall thickness over 1,0 % up to and including 1,5 % of outside parameter : 3,0 x tolerance ;
- wall thickness over 0,5 % up to and including 1,0 % of outside parameter : 4,0 x tolerance.

2) These tolerances do not apply to tempers O and Tx510. For these tempers the tolerances shall be subject to agreement between the supplier and the purchaser.

3.4 Wall thickness

The tolerances on wall thickness are specified in table 4 for round tubes and in table 5 for other than round tubes.

Table 4 : Tolerances on wall thickness for round tubes

Nominal wall thickness t mm		Tolerance on wall thickness measured at any point
Over	Up to and including	%
≥ 0,5	2	± 10
2	3	± 9
3	-	± 8