

---

---

**Metallic materials — Sheet and strip —  
Hole expanding test**

*Matériaux métalliques — Tôles et bandes — Essai d'expansion de trou*

**iTeh STANDARD PREVIEW**  
**(standards.iteh.ai)**

ISO 16630:2009

<https://standards.iteh.ai/catalog/standards/sist/f23886be-a28e-4f8e-a2a8-2bc3e4732532/iso-16630-2009>



**PDF disclaimer**

This PDF file may contain embedded typefaces. In accordance with Adobe's licensing policy, this file may be printed or viewed but shall not be edited unless the typefaces which are embedded are licensed to and installed on the computer performing the editing. In downloading this file, parties accept therein the responsibility of not infringing Adobe's licensing policy. The ISO Central Secretariat accepts no liability in this area.

Adobe is a trademark of Adobe Systems Incorporated.

Details of the software products used to create this PDF file can be found in the General Info relative to the file; the PDF-creation parameters were optimized for printing. Every care has been taken to ensure that the file is suitable for use by ISO member bodies. In the unlikely event that a problem relating to it is found, please inform the Central Secretariat at the address given below.

**iTeh STANDARD PREVIEW**  
**(standards.iteh.ai)**

ISO 16630:2009

<https://standards.iteh.ai/catalog/standards/sist/f23886be-a28e-4f8e-a2a8-2bc3e4732532/iso-16630-2009>



**COPYRIGHT PROTECTED DOCUMENT**

© ISO 2009

All rights reserved. Unless otherwise specified, no part of this publication may be reproduced or utilized in any form or by any means, electronic or mechanical, including photocopying and microfilm, without permission in writing from either ISO at the address below or ISO's member body in the country of the requester.

ISO copyright office  
Case postale 56 • CH-1211 Geneva 20  
Tel. + 41 22 749 01 11  
Fax + 41 22 749 09 47  
E-mail [copyright@iso.org](mailto:copyright@iso.org)  
Web [www.iso.org](http://www.iso.org)

Published in Switzerland

**Contents**

Page

Foreword.....	iv
Introduction .....	v
1 Scope .....	1
2 Normative references .....	1
3 Terms and definitions.....	1
4 Symbols and abbreviated terms .....	1
5 Principle.....	2
6 Apparatus .....	3
7 Test piece .....	3
8 Test procedure .....	5
9 Calculation of test data .....	6
10 Test report .....	7

**iTeh STANDARD PREVIEW**  
**(standards.iteh.ai)**

[ISO 16630:2009](https://standards.iteh.ai/catalog/standards/sist/f23886be-a28e-4f8e-a2a8-2bc3e4732532/iso-16630-2009)

<https://standards.iteh.ai/catalog/standards/sist/f23886be-a28e-4f8e-a2a8-2bc3e4732532/iso-16630-2009>

## Foreword

ISO (the International Organization for Standardization) is a worldwide federation of national standards bodies (ISO member bodies). The work of preparing International Standards is normally carried out through ISO technical committees. Each member body interested in a subject for which a technical committee has been established has the right to be represented on that committee. International organizations, governmental and non-governmental, in liaison with ISO, also take part in the work. ISO collaborates closely with the International Electrotechnical Commission (IEC) on all matters of electrotechnical standardization.

International Standards are drafted in accordance with the rules given in the ISO/IEC Directives, Part 2.

The main task of technical committees is to prepare International Standards. Draft International Standards adopted by the technical committees are circulated to the member bodies for voting. Publication as an International Standard requires approval by at least 75 % of the member bodies casting a vote.

Attention is drawn to the possibility that some of the elements of this document may be the subject of patent rights. ISO shall not be held responsible for identifying any or all such patent rights.

ISO 16630 was prepared by Technical Committee ISO/TC 164, *Mechanical testing of metals*, Subcommittee SC 2, *Ductility testing*.

This first edition of ISO 16630 cancels and replaces ISO/TS 16630:2003, which has been technically revised.

**iTeh STANDARD PREVIEW**  
**(standards.iteh.ai)**

ISO 16630:2009

<https://standards.iteh.ai/catalog/standards/sist/f23886be-a28e-4f8e-a2a8-2bc3e4732532/iso-16630-2009>

## Introduction

Modern methods of manufacture of automobile components such as wheels, suspension parts and structural components using sheet metal, mainly steel and possibly other metals, involve, primarily, shearing, bending and stretch drawing operations.

Included with these processes are the bending up (plunging) of flanges (rims) around punched holes, and this can result in rupture of the material.

Various test methods are available to establish the suitability of the sheet metal for the forming processes involved. The hole expanding test is one of the best methods for evaluating the suitability of the sheet metal for forming such “flanges” because it closely resembles the process used under production conditions to form such flanges (plunged rims) starting with punched holes.

Because of the details given in this International Standard, the relevance of the test will be immediately apparent. By adhering to the procedures laid down in this International Standard, scatter in the test results will be minimized.

## iTeh STANDARD PREVIEW (standards.iteh.ai)

[ISO 16630:2009](https://standards.iteh.ai/catalog/standards/sist/f23886be-a28e-4f8e-a2a8-2bc3e4732532/iso-16630-2009)

<https://standards.iteh.ai/catalog/standards/sist/f23886be-a28e-4f8e-a2a8-2bc3e4732532/iso-16630-2009>

**iTeh STANDARD PREVIEW**  
**(standards.iteh.ai)**

ISO 16630:2009

<https://standards.iteh.ai/catalog/standards/sist/f23886be-a28e-4f8e-a2a8-2bc3e4732532/iso-16630-2009>

# Metallic materials — Sheet and strip — Hole expanding test

## 1 Scope

This International Standard describes a method of determining the hole expansion ratio in metallic sheets and strips with a thickness range of 1,2 mm to 6,0 mm inclusive and a width of at least 90 mm.

NOTE This test is normally applicable to sheet metal and is used to assess the suitability of the product for forming flanges.

## 2 Normative references

The following referenced documents are indispensable for the application of this document. For dated references, only the edition cited applies. For undated references, the latest edition of the referenced document (including any amendments) applies.

ISO 497:1973, *Guide to the choice of series of preferred numbers and of series containing more rounded values of preferred numbers*

## 3 Terms and definitions

ISO 16630:2009

[https://standards.iteh.ai/catalog/standards/sist/f23886be-a28e-4f8e-a2a8-](https://standards.iteh.ai/catalog/standards/sist/f23886be-a28e-4f8e-a2a8-2be3e4732532/iso-16630-2009)

For the purposes of this document, the following terms and definitions apply.

### 3.1

#### limiting hole expansion ratio

amount of hole expansion obtained in a circular punched hole of a test piece when a conical expanding tool is forced into the hole until any one crack in the hole edge extends through the test piece thickness

NOTE The limiting hole expansion ratio is expressed as the ratio of hole diameter expansion to the original hole diameter.

### 3.2

#### clearance

⟨between die and punch⟩ gap between the die and the punch, present when punching a hole in a test piece

NOTE Clearance is expressed as the ratio of the gap to the test piece thickness.

## 4 Symbols and abbreviated terms

Symbols and corresponding designations used in this International Standard are given in Table 1.

Table 1 — Symbols and designations

Symbol	Designation	Unit
$c$	Clearance	%
$d_d$	Inside diameter of the die used for punching a hole in the test piece	mm
$d_p$	Diameter of the punch used for punching a hole in the test piece	mm
$D_d$	Inside diameter of the die of the expanding tool	mm
$D_h$	Average hole diameter after rupture	mm
$D_o$	Original hole diameter	mm
$D_p$	Diameter of the punch of the expanding tool	mm
$F$	Clamping force	N
$R$	Corner radius of the die of the expanding tool	mm
$t$	Thickness of the test piece	mm
$\lambda$	Limiting hole expansion ratio	%
$\bar{\lambda}$	Average limiting hole expansion ratio	%

5 Principle

The hole expanding test consists of two steps:

- a) punching a hole as indicated in Figure 1;
- b) forcing a conical expanding tool into a pre-punched hole until any one crack extends through the test piece thickness of the metallic sheet.

iTech STANDARD PREVIEW  
(standards.iteh.ai)  
ISO 16630:2009  
<https://standards.iteh.ai/catalog/standards/sist/f23886be-a28e-4f8e-a2a8-2bc3e4732532/iso-16630-2009>

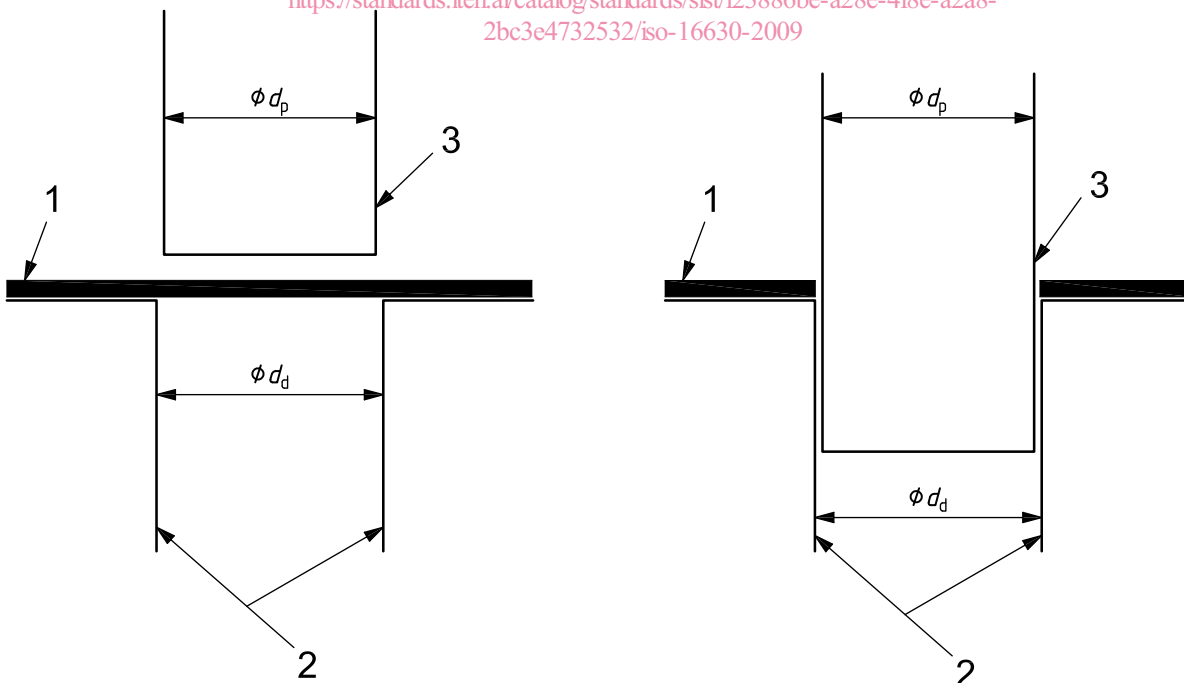

- Key
- 1 test piece
  - 2 die used for punching a hole
  - 3 punch used for punching a hole

Figure 1 — Illustration of punching



## 6 Apparatus

### 6.1 General

The apparatus consists of a testing machine and testing tools.

### 6.2 Testing machine

The testing machine shall have the capability to hold a test piece in place during the test and be able to stop the expanding tool as soon as a crack occurs in the hole edge.

The testing machine shall also be capable of controlling the rate of displacement of the expanding tool.

A testing machine intended exclusively for hole expanding tests, or a deep drawing test machine, or any other press testing machine may be used.

### 6.3 Testing tools

**6.3.1** The dimensions and the shape of the die and of the punch used in the hole expanding test are given in 6.3.2 to 6.3.5 (also see Figure 3).

**6.3.2** The punch shall be a conical expanding tool with a tip angle of  $60^\circ \pm 1^\circ$ . The diameter,  $D_p$ , of the cylindrical portion of the tool shall be sufficiently large that it can expand the hole to such an extent that cracks are generated in the hole edge of the test piece.

**6.3.3** The test tool clamping die inside diameter,  $D_d$ , shall be selected on the basis of the expected limiting hole expansion ratio.

The inside diameter,  $D_d$ , should not be smaller than 40 mm.

**6.3.4** The corner radius,  $R$ , of the test tool clamping die shall be between 2 mm and 20 mm.

The recommended radius is 5 mm.

**6.3.5** The conical expanding tool shall have a minimum hardness of 55 HRC.

## 7 Test piece

**7.1** Three test pieces shall be taken from the same sample (see, however, 8.2).

**7.2** The test piece shall be flat and of such dimensions that the centre of any hole is not less than 45 mm from any edge of the test piece nor less than 90 mm from the centre of the adjacent hole (see Figure 2).

Dimensions in millimetres

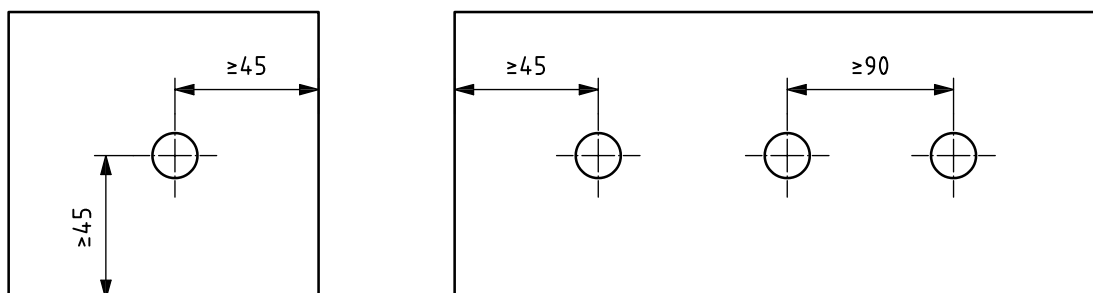

Figure 2 — Dimensions of the test pieces