

---

---

**Methods for the petrographic analysis of  
coals —**

Part 3:  
**Method of determining maceral group  
composition**

**iTeh STANDARD PREVIEW**  
*Méthodes d'analyse pétrographique des charbons —*  
*(standards.iteh.ai)* *Partie 3: Détermination de la composition en groupes de macéraux*

[ISO 7404-3:2009](https://standards.iteh.ai/catalog/standards/sist/307038cf-bee1-4bfl-a1a2-ac065d11a677/iso-7404-3-2009)

<https://standards.iteh.ai/catalog/standards/sist/307038cf-bee1-4bfl-a1a2-ac065d11a677/iso-7404-3-2009>



**PDF disclaimer**

This PDF file may contain embedded typefaces. In accordance with Adobe's licensing policy, this file may be printed or viewed but shall not be edited unless the typefaces which are embedded are licensed to and installed on the computer performing the editing. In downloading this file, parties accept therein the responsibility of not infringing Adobe's licensing policy. The ISO Central Secretariat accepts no liability in this area.

Adobe is a trademark of Adobe Systems Incorporated.

Details of the software products used to create this PDF file can be found in the General Info relative to the file; the PDF-creation parameters were optimized for printing. Every care has been taken to ensure that the file is suitable for use by ISO member bodies. In the unlikely event that a problem relating to it is found, please inform the Central Secretariat at the address given below.

**iTeh STANDARD PREVIEW**  
**(standards.iteh.ai)**

ISO 7404-3:2009

<https://standards.iteh.ai/catalog/standards/sist/307038cf-bee1-4bfl-a1a2-ac065d11a677/iso-7404-3-2009>



**COPYRIGHT PROTECTED DOCUMENT**

© ISO 2009

All rights reserved. Unless otherwise specified, no part of this publication may be reproduced or utilized in any form or by any means, electronic or mechanical, including photocopying and microfilm, without permission in writing from either ISO at the address below or ISO's member body in the country of the requester.

ISO copyright office  
Case postale 56 • CH-1211 Geneva 20  
Tel. + 41 22 749 01 11  
Fax + 41 22 749 09 47  
E-mail [copyright@iso.org](mailto:copyright@iso.org)  
Web [www.iso.org](http://www.iso.org)

Published in Switzerland

## Contents

Page

Foreword .....	iv
Introduction.....	v
1 Scope .....	1
2 Normative references .....	1
3 Terms and definitions .....	1
4 Principle .....	1
5 Reagents and materials .....	1
6 Apparatus .....	2
7 Preparation of coal sample .....	2
8 Procedure .....	2
9 Expression of results .....	3
10 Precision .....	4
11 Test report .....	5
Annex A (informative) Sub-division of maceral groups .....	6
Bibliography .....	7

[ISO 7404-3:2009](https://standards.iteh.ai/catalog/standards/sist/307038cf-bee1-4bfl-a1a2-ac065d11a677/iso-7404-3-2009)  
<https://standards.iteh.ai/catalog/standards/sist/307038cf-bee1-4bfl-a1a2-ac065d11a677/iso-7404-3-2009>

## Foreword

ISO (the International Organization for Standardization) is a worldwide federation of national standards bodies (ISO member bodies). The work of preparing International Standards is normally carried out through ISO technical committees. Each member body interested in a subject for which a technical committee has been established has the right to be represented on that committee. International organizations, governmental and non-governmental, in liaison with ISO, also take part in the work. ISO collaborates closely with the International Electrotechnical Commission (IEC) on all matters of electrotechnical standardization.

International Standards are drafted in accordance with the rules given in the ISO/IEC Directives, Part 2.

The main task of technical committees is to prepare International Standards. Draft International Standards adopted by the technical committees are circulated to the member bodies for voting. Publication as an International Standard requires approval by at least 75 % of the member bodies casting a vote.

Attention is drawn to the possibility that some of the elements of this document may be the subject of patent rights. ISO shall not be held responsible for identifying any or all such patent rights.

ISO 7404-3 was prepared by Technical Committee ISO/TC 27, *Solid mineral fuels*.

This third edition cancels and replaces the second edition (ISO 7404-3:1994), which has been technically revised.

ISO 7404 consists of the following parts, under the general title *Methods for the petrographic analysis of coals*:

- Part 1: Vocabulary<sup>1)</sup>
- Part 2: Methods of preparing coal samples
- Part 3: Method of determining maceral group composition
- Part 4: Method of determining microlithotype, carbominerite and minerite composition<sup>1)</sup>
- Part 5: Method of determining microscopically the reflectance of vitrinite

---

1) Parts 1 and 4 of this International Standard will be available under the original title, *Methods for the petrographic analysis of bituminous coal and anthracite*, until the revisions of these documents have reached the stage at which they are publicly available.

## Introduction

Petrographic analyses have been recognized internationally as important in the context of the genesis, vertical and lateral variation, continuity, metamorphism and usage of coal. The International Committee for Coal and Organic Petrology (ICCP) has made recommendations concerning nomenclature and analytical methods and has published an extensive handbook, describing the characteristics of a wide range of coals. The ICCP also runs an accreditation program for maceral group analysis. The text of this part of ISO 7404 agrees with text of the handbook and incorporates many useful comments made by members of the ICCP and by member bodies of ISO/TC 27, *Solid mineral fuels*.

ISO 11760, *Classification of coals*, uses the maceral group composition as one of three parameters to classify coal; the other parameters are vitrinite reflectance and ash yield, respectively, for rank and grade.

Petrographic analyses of a single coal provide information about the rank, the maceral and microlithotype compositions and the distribution of minerals in the coal. The reflectance of vitrinite (or huminite) is a useful measure of coal rank and the distribution of the reflectance of vitrinite (or huminite) in a coal blend, together with a maceral group analysis, can provide information about some important chemical and technological properties of the blend.

ISO 7404 (all parts) is concerned with the methods of petrographic analysis currently employed in characterizing coal in the context of its technological use. It establishes a system for petrographic analysis.

For information on the nomenclature and analysis of brown coals and lignites, reference should be made to the International Handbook of Coal Petrography published by ICCP.

Macerals are microscopically recognizable organic constituents of coal, and can be grouped together into three maceral groups: vitrinite (or huminite in lower rank coal), liptinite and inertinite.

Maceral groups and their subdivisions are listed in Annex A and described in detail in ISO 7404-1. The properties of a given coal are determined by the proportions and associations of the macerals and minerals present and by the rank of the coal. The method of determining maceral group composition described in this part of ISO 7404 applies to determinations made in reflected white light; the additional use of fluorescence microscopy is recommended when analysing lower rank coals.

In addition to the macerals, it is possible to identify certain minerals in coal; these can either be determined as separate categories or be ignored. As some of the minerals cannot be satisfactorily determined under the microscope, an estimate of the total mineral matter content can be obtained from the ash.

Annex A of this part of ISO 7404 is for information only.

**iTeh STANDARD PREVIEW**  
**(standards.iteh.ai)**

ISO 7404-3:2009

<https://standards.iteh.ai/catalog/standards/sist/307038cf-bee1-4bfl-a1a2-ac065d11a677/iso-7404-3-2009>

# Methods for the petrographic analysis of coals —

## Part 3: Method of determining maceral group composition

### 1 Scope

This part of ISO 7404 specifies a method for determining the proportions of the maceral groups (and the minerals, if desired) in coals. It is concerned only with determinations made on polished particulate blocks using incident white light. For lower-rank coals, the additional use of the fluorescence mode is necessary to identify liptinites.

### 2 Normative references

The following referenced documents are indispensable for the application of this document. For dated references, only the edition cited applies. For undated references, the latest edition of the referenced document (including any amendments) applies.

ISO 7404-1, *Methods for the petrographic analysis of bituminous coal and anthracite — Part 1: Vocabulary*  
[ISO 7404-3:2009](https://standards.iteh.ai/catalog/standards/sist/307028cf1bee14bf1a1a2ac065d11a677/iso-7404-3-2009)

ISO 7404-2, *Methods for the petrographic analysis of coals — Part 2: Method of preparing coal samples*  
<https://standards.iteh.ai/catalog/standards/sist/307028cf1bee14bf1a1a2ac065d11a677/iso-7404-3-2009>

ISO 11760, *Classification of coals*

### 3 Terms and definitions

For the purposes of this document, the terms and definitions given in ISO 7404-1 apply.

### 4 Principle

A representative sample of coal is used to prepare a particulate block as described in ISO 7404-2. This is examined using a reflected light microscope and the macerals are identified under an immersion medium by their relative reflectance, colour, size and morphology. Their proportions are determined by a point-count procedure.

### 5 Reagents and materials

**5.1 Immersion medium**, having a suitable refractive index and compatible with the microscope objective.

It is necessary that the oil not react with either the coal or binder. It is recommended that an oil with a refractive index of 1,518 0 as described in ISO 7404-5 be used, especially if the reflectance of the macerals is being measured.

## 6 Apparatus

**6.1 Reflected light microscope**, having an immersion objective of magnification between 25x and 60x and an eyepiece of magnification between 8x and 12x, to ensure a minimum total magnification of 300x.

The eyepiece incorporates a fine crosshairs graticule.

**6.2 Mechanical stage**, capable of advancing the specimen laterally by equal steps of such length that only a negligibly small proportion of the particles examined receives more than one count on the same particle.

The stage also permits a similar stepped advance in the perpendicular direction. The lateral movement is actuated preferably by the counter mechanism, whereas the perpendicular movement can be satisfactorily performed manually.

**6.3 Counter**, capable of registering the counts in each category and preferably the grand total of petrographic components.

**6.4 Sample mounting equipment**, comprised of slides, modelling clay and a levelling device.

## 7 Preparation of coal sample

Prepare and polish a particulate block in accordance with ISO 7404-2.

## 8 Procedure

iTeh STANDARD PREVIEW  
(standards.iteh.ai)

Adjust the microscope (6.1) for Köhler illumination. Set up the levelled particulate block on the stage, place the immersion medium (5.1) on the surface of the block, focus and observe the image in the microscope. Identify the material lying under the intersection of the crosshairs and carry out the point count procedure as follows.

Crosshairs on

Action:

vitritinite, inertinite, liptinite, etc.:

Operate the counter for appropriate maceral or maceral group.

mounting medium:

Ignore the point.

boundary between macerals or between macerals and mounting medium:

Examine in turn the material lying immediately adjacent to crosshairs intersection in the top right, bottom right, bottom left and top left quadrants. Take the first of these that does not have a boundary in it, and operate the counter for this material; see Figure 1.

empty pore in a maceral void:

Ignore the point.

Advance the block by one step in the left-to-right direction and continue counting and traversing the specimen. At the end of a traverse, advance the block by a step of at least equal length in the perpendicular direction to start the next parallel traverse. Choose the step length to ensure a uniform counting of points over the surface of the block.

Count a total of at least 500 points, excluding minerals.

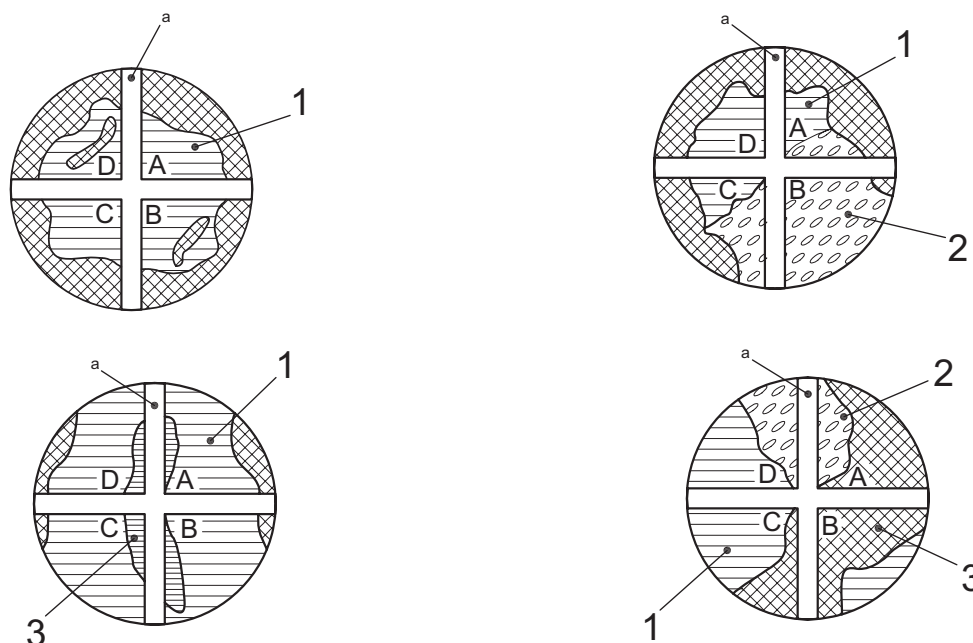

**Key**

- 1 vitrinite
- 2 inertinite
- 3 liptinite

a Width of crosshairs exaggerated for clarity.

iTeh STANDARD PREVIEW  
(standards.iteh.ai)

**Figure 1 — Normal and boundary cases between macerals or between macerals and mounting medium**

ISO 7404-3:2009  
<https://standards.iteh.ai/catalog/standards/sist/307038cf-bee1-4bfl-a1a2-ac065d11a677/iso-7404-3-2009>

## 9 Expression of results

### 9.1 Maceral groups

Calculate the percentage volume fraction of each component [vitrinite,  $V_V$ ; liptinite,  $V_L$ , or inertinite,  $V_I$ ], which is equal to the percentage number of points counted on it, expressing the results either to the nearest integer or to one decimal place. The form of the results depends on the procedure adopted with regard to minerals (see the last three paragraphs) and is expressed as given in Equation (1) if the minerals are ignored, as given in Equation (2) if the percentage volume fraction of the minerals,  $V_M$ , is determined from counting, and as given in Equation (3) if the volume percentage of the minerals,  $V_M$ , is calculated:

$$V_V + V_L + V_I = 100 \quad (1)$$

$$V_V + V_L + V_I + V_M = 100 \quad (2)$$

$$V_V + V_L + V_I + V_M = 100 \quad (3)$$

For Equation (3), the minerals are ignored in the point count but the volume percentage of mineral matter is calculated from a determination of the ash content by means of an accepted empirical relationship.

The procedure adopted and the number of points counted shall be indicated in the test report.