

# INTERNATIONAL STANDARD

ISO  
340

Second edition  
1988-06-15



---

INTERNATIONAL ORGANIZATION FOR STANDARDIZATION  
ORGANISATION INTERNATIONALE DE NORMALISATION  
МЕЖДУНАРОДНАЯ ОРГАНИЗАЦИЯ ПО СТАНДАРТИЗАЦИИ

---

## Conveyor belts — Flame retardation — Specifications and test method

*Courroies transporteuses — Résistance à la flamme — Spécifications et méthode d'essai*

**STANDARD PREVIEW**  
**(standards.iteh.ai)**

ISO 340:1988

<https://standards.iteh.ai/catalog/standards/sist/6c8a496b-1ee8-4569-b4e8-114621fca547/iso-340-1988>

Reference number  
ISO 340:1988 (E)

## Foreword

ISO (the International Organization for Standardization) is a worldwide federation of national standards bodies (ISO member bodies). The work of preparing International Standards is normally carried out through ISO technical committees. Each member body interested in a subject for which a technical committee has been established has the right to be represented on that committee. International organizations, governmental and non-governmental, in liaison with ISO, also take part in the work. ISO collaborates closely with the International Electrotechnical Commission (IEC) on all matters of electrotechnical standardization.

Draft International Standards adopted by the technical committees are circulated to the member bodies for approval before their acceptance as International Standards by the ISO Council. They are approved in accordance with ISO procedures requiring at least 75 % approval by the member bodies voting.

International Standard ISO 340 was prepared by Technical Committee ISO/TC 41, *Pulleys and belts (including veebelts)*.

ISO 340:1988

<https://standards.iteh.ai/catalog/standards/sist/6c8a496b-1ee8-4569-b4e8-114621ca2774/iso-340-1988>

This second edition cancels and replaces the first edition (ISO 340 : 1942), clauses 0, 1, 4 and 5 of which have been technically revised.

Users should note that all International Standards undergo revision from time to time and that any reference made herein to any other International Standard implies its latest edition, unless otherwise stated.

# Conveyor belts — Flame retardation — Specifications and test method

## 0 Introduction

In many countries, specifications of flame retardation of conveyor belts and the corresponding methods of test are the subject of legislation. However, it has been thought necessary to prepare an International Standard in order to give a reference if there is no particular legislation.

It is stressed that for small-scale laboratory tests of the type covered in this International Standard, the correlation of test results with the flammability under other conditions is not in any case implied. For this reason, the relevant conditions of belt use shall be taken into account in order not to obtain a false sense of security by uncritical application of this International Standard.

## 1 Scope and field of application

This International Standard specifies conditions for a flame retardation test for conveyor belts, and the corresponding requirements.

NOTE — To increase safety, it is important for tests to take into account, as far as possible, the circumstances which may create hazards. It is for this reason that, in this International Standard, provision is made for performing the test on test pieces without covers, as covers of belts may be ripped off accidentally in service.

## 2 References

ISO 235, *Parallel shank twist jobber and stub series drills and Morse taper shank drills.*

ISO 426-2, *Wrought copper-zinc alloys — Chemical composition and forms of wrought products — Part 2 : Leaded copper-zinc alloys.*

ISO 565, *Test sieves — Woven metal wire cloth, perforated plate and electroformed sheet — Nominal sizes of openings.*

ISO 835, *Laboratory glassware — Graduated pipettes.*

ISO 2194, *Wire screens and plate screens for industrial purposes — Nominal sizes of apertures.*

ISO 3310-1, *Test sieves — Technical requirements and testing — Part 1 : Test sieves of metal wire cloth.*

ISO 3310-2, *Test sieves — Technical requirements and testing — Part 2 : Test sieves of metal perforated plate.*

## 3 Specifications

### 3.1 Duration of flame (after removal of the burner)

The duration of flame shall be less than 45 s for each group of six tests, and no individual value shall be greater than 15 s (see 4.7.1).

### 3.2 Non-reappearance of flame (after applying a current of air)

The flame shall not reappear (see 4.7.2).

## 4 Test method

### 4.1 Principle

A test piece is placed in the flame of a burner, the burner is removed and the combustion time of the test piece is noted (duration of flame). A current of air is then applied to the test piece at a specified time after the removal of the burner and the reappearance of the flame is noted.

### 4.2 Test pieces

#### 4.2.1 Shape and dimensions

Rectangular test piece (cut out from the conveyor belt) :

- length : 200 mm
- width : 25 mm

#### 4.2.2 Number and distribution

4.2.2.1 If the test is made on test pieces with and without covers, prepare 12 test pieces distributed as follows :

- with covers : 3 warp way and 3 weft way;
- without covers : 3 warp way and 3 weft way.

4.2.2.2 If the test is made on test pieces with covers only, prepare 6 test pieces, 3 warp way and 3 weft way.

#### 4.2.3 Preparation

Cut out the test pieces with a knife.

For test pieces without covers, remove the covers by stripping or, if this is impossible, with a knife or by buffing. In the latter event, take care that the cover is not abnormally overheated, and cease buffing as soon as the threads of the carcass become visible.

#### 4.3 Burners

##### 4.3.1 Operation

On agreement between the parties concerned one of the burners specified in 4.3.2 and 4.3.3 shall be used.

##### 4.3.2 Spirit burner

The spirit burner, its characteristics and operating conditions, the fuel, and the tank and flexible supply tube of approximately 1,5 m length are specified in figure 1 and the annex.

During the test the fuel consumption of the burner shall be  $2,55 \pm 0,15$  ml/min giving a flame length of approximately 150 to 180 mm.

Check that the burner is operating properly by measuring the fuel flow according the method described in A.3.3.

##### 4.3.3 Gas burner

The gas burner (Bunsen burner) with burner tube of diameter between 10 and 12 mm shall be operated with town gas or liquid petroleum gas.

During the test the burner shall have a flame of a total length of approximately 150 to 180 mm with an inner flame of about 50 mm long. The inner flame temperature shall be  $900 \pm 100$  °C. A thermocouple device may be used to measure the inner flame temperature.

#### 4.4 Ambient conditions

Operate in an open atmosphere, sheltered from draughts.

#### 4.5 Arrangement of test pieces

On agreement between the parties concerned the test pieces shall be arranged vertically (see 4.5.1) or inclined at 45° (see 4.5.2).

**4.5.1** Arrange the test piece vertically (with its major axis vertical) so that its lower edge is 50 mm away from the top of the burner.

The burner shall be inclined at 45° and the vertical plane through its axis shall coincide with the midplane of the test piece parallel to the covers (see figure 2).

**4.5.2** Arrange the burner vertically and the test piece inclined at 45°. The relative position between test piece and burner shall be as described in 4.5.1 (see figure 3).

#### 4.6 Procedure

Hold the test piece in the flame for 45 s and then remove the burner without extinguishing it. (Keep the burner sheltered from the current of air, if further tests are to be performed.)

Note the duration of flame, starting from this moment.

One minute (with a tolerance of  $\pm 5$  s) after the removal of the burner, apply a current of air with a velocity of about 1,5 m/s (see figures 2 and 3).

#### 4.7 Expression of results

##### 4.7.1 Duration of flame (after removal of the burner)

**4.7.1.1** Express the results by :

a) total of results of 6 tests with covers, i.e. :

3 warp way, 3 weft way;

b) whenever relevant, total of results of 6 tests without covers, i.e. :

3 warp way, 3 weft way.

**4.7.1.2** Note, in each of cases 4.7.1.1 a) and b), the maximum value of the individual results obtained.

##### 4.7.2 Non-reappearance of flame

Note whether or not the flame reappears.

#### 5 Test report

The test report shall refer to this International Standard and shall contain the following information :

- identification of the belt tested;
- description of the burner used;
- description of the test piece arrangement;
- results of the test, as described in 4.7;
- date of the test.

Dimensions in millimetres

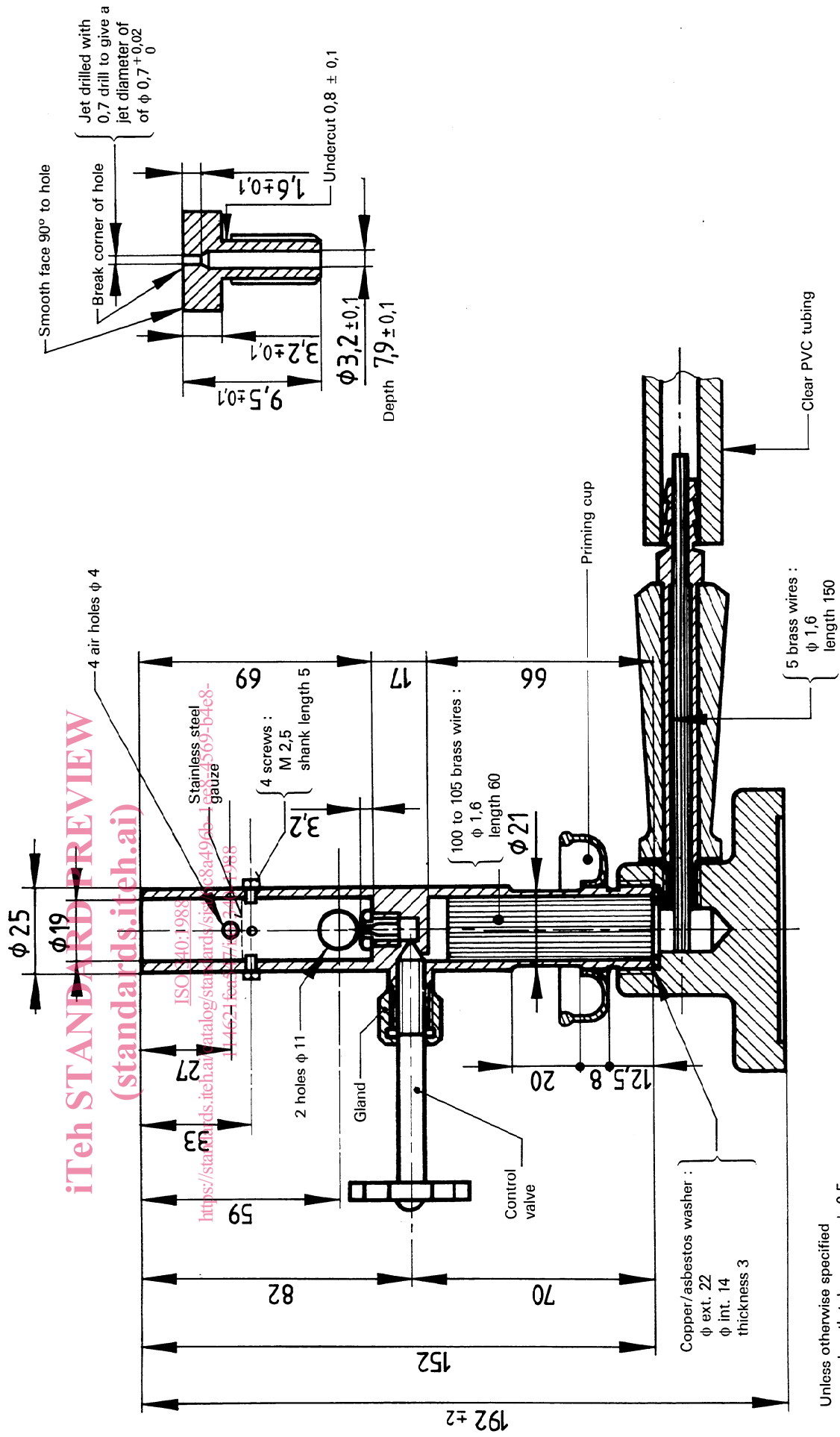

Figure 1 — Spirit burner

Unless otherwise specified  
 — length tolerances :  $\pm 0,5$   
 — diameter tolerances :  $\pm 0,1$

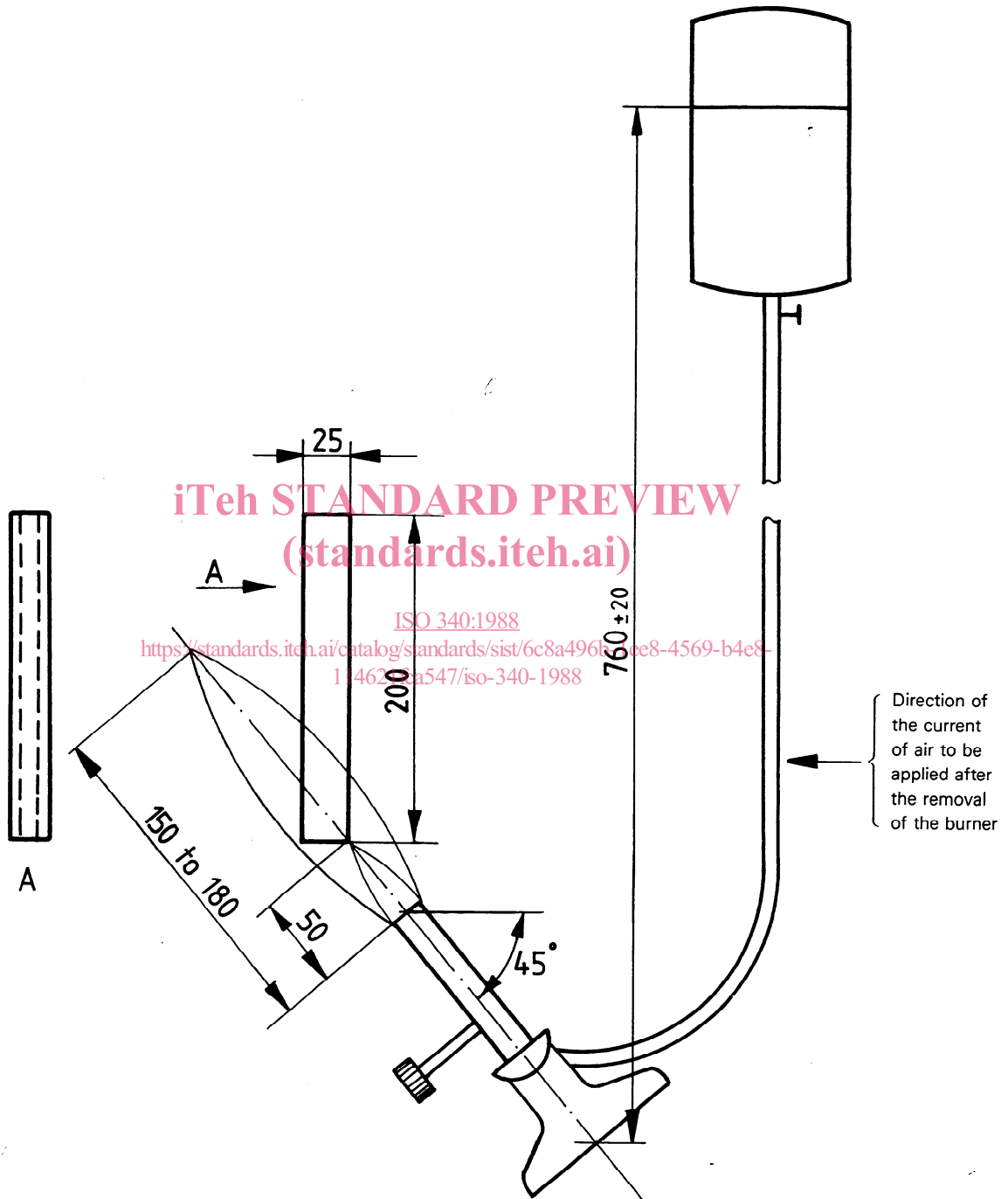

Figure 2 — Direction of air current

Dimensions in millimetres

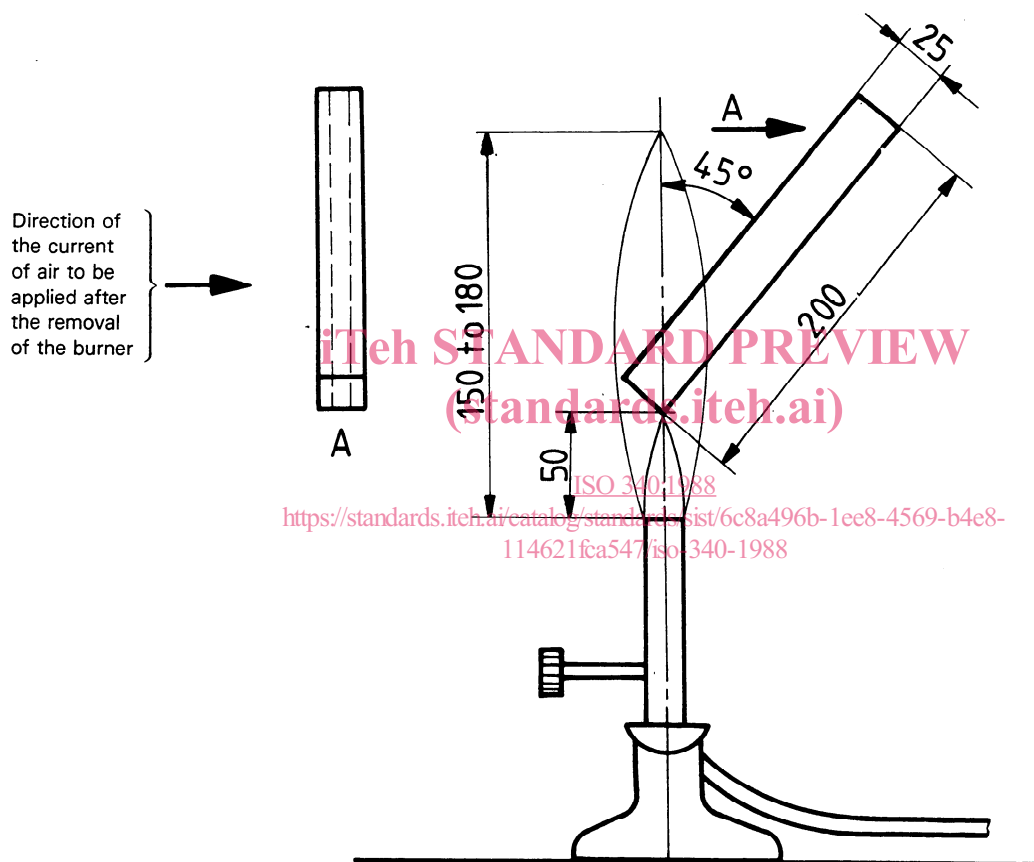

Figure 3 — Burner vertical

## Annex

### Description and operating conditions of the spirit burner

(This annex forms an integral part of the standard.)

#### A.1 Scope and field of application

This annex describes the burner used for evaluating the flame retardation of conveyor belts as well as its operating conditions.

#### A.2 Apparatus

Dimensions of the burner are given in figure 1. In certain atmospheres, the flame tube above the air holes corrodes, resulting in a tapered out surface; provided that the inner diameter and overall height of the flame tube are not affected, this tapering is not detrimental to the satisfactory operation of the burner. The burner jet shall be drilled with a 0,7 mm drill complying with the requirements of ISO 235 to give a jet diameter of  $0,7 \pm 0,02$  mm.

##### A.2.1 Construction materials

The components of the burner shall be made from materials as follows :

- flame tube : brass, complying with the requirements for grade Cu Zn 39 Pb 3 of ISO 426-2;
- base : steel;
- gauze : stainless steel, 500  $\mu$ m nominal aperture size (30 mesh) complying with the requirements of ISO 565, ISO 2194, ISO 3310-1 and ISO 3310-2;
- jet : brass complying with grade Cu Zn 39 Pb 3 of ISO 426-2;
- packing rods : brass complying with grade Cu Zn 39 Pb 3 of ISO 426-2.

##### A.2.2 Joint sealing

The joints in the burner shall be sealed as follows :

- base of flame tube: fully enclosed copper/asbestos joint ring, 22 mm outside diameter, 14 mm inside diameter, and 3 mm thick;
- gland of on/off control : asbestos string;
- retaining nut of on/off control : polytetrafluoroethylene (PTFE) tape;
- jet (between the face of the jet and the top of the jet seat) : PTFE tape rolled into a string and applied as a collar around the neck of the jet.

#### A.2.3 Fuel reservoir

The reservoir shall have a capacity of about 1 000 ml, fitted with a side-arm graduated at 0,1 ml\* intervals, a stopcock and a length of clear flexible PVC tubing (see figure 2).

#### A.2.4 Fuel

The fuel shall be a mixture of 5 % (V/V) of methanol and 95 % (V/V) of ethanol.

NOTE — The fuel should be free from suspended matter, and should be filtered before use.

#### A.3 Operation of the burner

##### A.3.1 Setting up

Connect the reservoir to the burner and adjust its height so that the fuel level is  $760 \pm 20$  mm above the centre of the bottom of the base of the burner. **It is essential to ensure that this height is maintained throughout the tests.**

##### A.3.2 Lighting the burner

With the control valve closed and the reservoir stopcock open, check that the fuel consumption is zero.

Fill the priming cup to three-quarter capacity with the fuel and ignite it.

Immediately this fuel ceases to burn, fully open the control valve (at least one full turn), light the burner at the top of the flame tube and allow the flame to stabilize for 10 min.

##### A.3.3 Check of satisfactory operation

Check satisfactory operation by measuring the fuel flow to the burner as follows.

When the flame has stabilized, close the reservoir stopcock, thus feeding the burner from the calibrated side-arm. Measure the flow through the side-arm over a period of 1 min.

The fuel consumption shall be  $2,55 \pm 0,15$  ml/min.

#### A.4 Burner faults

##### A.4.1 Leakage

Leakage is indicated by a fuel consumption higher than specified and may occur at any of the joints in the burner or its fuel supply.

\* This graduated side-arm may be made conveniently from a 10 ml graduated pipette complying with ISO 835.



Leakage at any joint except the jet can be detected by igniting the leaking fuel. A more sensitive method is to use a battery-operated hot wire type of gas lighter, in which vapour from very small leakages can be detected by the visible rise in the temperature of the filament when it is brought close to the leaking joint. Gross leakage at the jet threads manifests itself as instability of the flame; slight leakage at these threads is virtually undetectable and therefore a high standard of assembly is essential.

#### A.4.2 Blockage

Any solid particle reaching the jet may stop or reduce the fuel flow. A fuel consumption below that specified is a clear indication of blockage.

Sources of solids include swarf from drilling the jet, dirt in the fuel, residues from evaporated spirit and corrosion products from the steel base of the burner.

#### A.5 Correction of faults

When the burner fails to operate in accordance with A.3.3, carry out the following procedure :

**A.5.1** Dismantle the burner.

**A.5.2** Remove all the brass wires from both the inlet tube and flame tube and remove all dirt from the interior of the burner, clean and replace the wires.

**A.5.3** Clear the jet.

**In clearing a blocked jet, exercise care to avoid enlarging the hole. Under no circumstances shall a "pricker" be used, as this quickly results in a non-circular oversize jet.**

Suitable methods for clearing jets are :

- to blow cleaning fluid from an aerosol pack fitted with a capillary outlet tube through the orifice;

or, if unsuccessful,

- to use a drill blank held in the fingers and inserted from the bottom of the jet to avoid damage to the outlet end.

**A.5.4** Re-assemble the burner using the appropriate sealing materials (see A.2.2).

**A.5.5** Check for leaks and correct fuel consumption.

iteh STANDARD PREVIEW  
(standards.iteh.ai)

[ISO 340:1988](https://standards.iteh.ai/catalog/standards/sist/6c8a496b-1ee8-4569-b4e8-114621fca547/iso-340-1988)

<https://standards.iteh.ai/catalog/standards/sist/6c8a496b-1ee8-4569-b4e8-114621fca547/iso-340-1988>