

---

---

**Single-use rubber gloves for general  
applications — Specification**

*Gants en caoutchouc à usages généraux, non réutilisables —  
Spécifications*

**iTeh STANDARD PREVIEW**  
**(standards.iteh.ai)**

ISO 25518:2009

<https://standards.iteh.ai/catalog/standards/sist/8b6ec746-f9d9-4871-a51c-efc85af577d2/iso-25518-2009>



**PDF disclaimer**

This PDF file may contain embedded typefaces. In accordance with Adobe's licensing policy, this file may be printed or viewed but shall not be edited unless the typefaces which are embedded are licensed to and installed on the computer performing the editing. In downloading this file, parties accept therein the responsibility of not infringing Adobe's licensing policy. The ISO Central Secretariat accepts no liability in this area.

Adobe is a trademark of Adobe Systems Incorporated.

Details of the software products used to create this PDF file can be found in the General Info relative to the file; the PDF-creation parameters were optimized for printing. Every care has been taken to ensure that the file is suitable for use by ISO member bodies. In the unlikely event that a problem relating to it is found, please inform the Central Secretariat at the address given below.

**iTeh STANDARD PREVIEW**  
**(standards.iteh.ai)**

ISO 25518:2009

<https://standards.iteh.ai/catalog/standards/sist/8b6ec746-f9d9-4871-a51c-efc85a577d2/iso-25518-2009>



**COPYRIGHT PROTECTED DOCUMENT**

© ISO 2009

All rights reserved. Unless otherwise specified, no part of this publication may be reproduced or utilized in any form or by any means, electronic or mechanical, including photocopying and microfilm, without permission in writing from either ISO at the address below or ISO's member body in the country of the requester.

ISO copyright office  
Case postale 56 • CH-1211 Geneva 20  
Tel. + 41 22 749 01 11  
Fax + 41 22 749 09 47  
E-mail [copyright@iso.org](mailto:copyright@iso.org)  
Web [www.iso.org](http://www.iso.org)

Published in Switzerland

## Foreword

ISO (the International Organization for Standardization) is a worldwide federation of national standards bodies (ISO member bodies). The work of preparing International Standards is normally carried out through ISO technical committees. Each member body interested in a subject for which a technical committee has been established has the right to be represented on that committee. International organizations, governmental and non-governmental, in liaison with ISO, also take part in the work. ISO collaborates closely with the International Electrotechnical Commission (IEC) on all matters of electrotechnical standardization.

International Standards are drafted in accordance with the rules given in the ISO/IEC Directives, Part 2.

The main task of technical committees is to prepare International Standards. Draft International Standards adopted by the technical committees are circulated to the member bodies for voting. Publication as an International Standard requires approval by at least 75 % of the member bodies casting a vote.

Attention is drawn to the possibility that some of the elements of this document may be the subject of patent rights. ISO shall not be held responsible for identifying any or all such patent rights.

ISO 25518 was prepared by Technical Committee ISO/TC 45, *Rubber and rubber products*, Subcommittee SC 4, *Products (other than hoses)*.

## iTeh STANDARD PREVIEW (standards.iteh.ai)

[ISO 25518:2009](https://standards.iteh.ai/catalog/standards/sist/8b6ec746-f9d9-4871-a51c-efc85af577d2/iso-25518-2009)

<https://standards.iteh.ai/catalog/standards/sist/8b6ec746-f9d9-4871-a51c-efc85af577d2/iso-25518-2009>

**iTeh STANDARD PREVIEW**  
**(standards.iteh.ai)**

ISO 25518:2009

<https://standards.iteh.ai/catalog/standards/sist/8b6ec746-f9d9-4871-a51c-efc85af577d2/iso-25518-2009>

# Single-use rubber gloves for general applications — Specification

**WARNING** — Persons using this International Standard should be familiar with normal laboratory practices. This standard does not purport to address all of the safety problems, if any, associated with its use. It is the responsibility of the user to establish appropriate safety and health practices and to ensure compliance with any regulatory conditions.

## 1 Scope

This International Standard specifies the physical requirements and methods of sampling and testing for single-use rubber gloves, made from natural rubber latex, synthetic rubber latex or rubber solution, intended for general applications, but not gloves intended for medical purposes.

It does not cover the safe and proper usage of the gloves.

## 2 Normative references

The following referenced documents are indispensable for the application of this document. For dated references, only the edition cited applies. For undated references, the latest edition of the referenced document (including any amendments) applies.

ISO 37, *Rubber, vulcanized or thermoplastic — Determination of tensile stress-strain properties*

ISO 188, *Rubber, vulcanized or thermoplastic — Accelerated ageing and heat resistance tests*

ISO 2859-1, *Sampling procedures for inspection by attributes — Part 1: Sampling schemes indexed by acceptance quality limit (AQL) for lot-by-lot inspection*

## 3 Requirements

### 3.1 Materials

Gloves shall be manufactured from suitable materials. Any pigment, surface treatment, lubricant or powder used shall be non-toxic and shall be disclosed on request. Substances used for the treatment that could be transferred to the skin during use shall not cause any harm.

### 3.2 Dimensions

When measured at the points shown in Figure 1, gloves shall comply with the dimensions for length and palm width given in Table 1, using the inspection level and AQL given in Table 3.

The measurement of length shall be the shortest distance between the tip of the second finger and the cuff end.

The length measurement may be taken by hanging the glove on a suitable mandrel with a tip radius of 5 mm.

The measurement of width shall be at the midpoint between the base of the index finger and the base of the thumb. The width measurement shall be made with the glove placed on a flat surface.

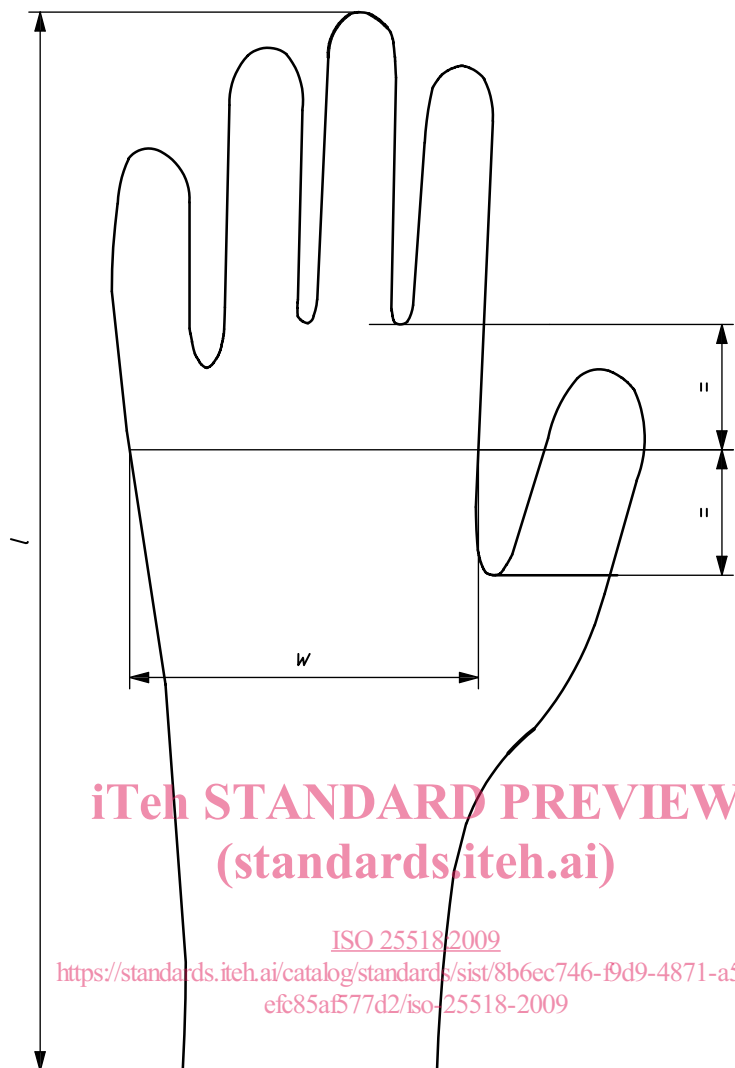

**Key**

- l* length of glove
- w* width of glove

**Figure 1 — Measurement points for width and length of the glove**

**Table 1 — Dimensions and tolerances**

Size	Width (dimension <i>w</i> in Figure 1) mm	Minimum length (dimension <i>l</i> in Figure 1) mm
Extra small (XS)	≤ 80	220
Small (S)	80 ± 10	220
Medium (M)	95 ± 10	230
Large (L)	110 ± 10	230
Extra large (XL)	≥ 110	230

### 3.3 Watertightness

When gloves are tested for watertightness as described in Annex A, the sample size and allowable number of non-conforming (i.e. leaking) gloves in the sample shall be determined in accordance with the inspection level and AQL given in Table 3.

### 3.4 Tensile properties

#### 3.4.1 General

Tensile properties shall be measured in accordance with ISO 37, taking three type 2 dumb-bell test pieces from each glove and using the median value as the test result. Test pieces shall be taken from the palm or back of the gloves.

#### 3.4.2 Force at break and elongation at break

When determined in accordance with the method specified in ISO 37, using type 2 dumb-bell test pieces, the force at break and elongation at break shall comply with the requirements given in Table 2, using the inspection level and AQL given in Table 3.

**Table 2 — Tensile properties**

Property	Requirement
Minimum force at break before accelerated ageing, N	7,0
Minimum elongation at break before accelerated ageing, %	500
Minimum force at break after accelerated ageing, N	6,0
Minimum elongation at break after accelerated ageing, %	400

<https://standards.iteh.ai/catalog/standards/sist/8b6ec746-19d9-4871-a51c-efc85af577d2/iso-25518-2009>

### 3.5 Accelerated ageing

Accelerated ageing shall be conducted in accordance with the method specified in ISO 188. Test pieces can be prepared either by ageing the gloves at  $70\text{ °C} \pm 2\text{ °C}$  for  $168\text{ h} \pm 2\text{ h}$  or at  $100\text{ °C} \pm 2\text{ °C}$  for 22 h and cutting the test pieces from the aged gloves, or by cutting the test pieces from unaged gloves and ageing the test pieces at  $70\text{ °C} \pm 2\text{ °C}$  for  $168\text{ h} \pm 2\text{ h}$  or at  $100\text{ °C} \pm 2\text{ °C}$  for 22 h. Tensile testing is then conducted as described in 3.4. The results shall comply with the requirements given in Table 2, using the inspection level and AQL as in Table 3.

## 4 Sampling and inspection

For referee purposes, gloves shall be sampled and inspected in accordance with ISO 2859-1. The inspection levels and acceptance quality limits (AQLs) shall conform to those specified in Table 3 for the characteristics listed.

When a lot size cannot be determined, a lot of 35 001 to 150 000 shall be assumed.

**Table 3 — Inspection levels and AQLs**

Characteristic	Inspection level	AQL
Physical dimensions (width, length)	S-2	6,5
Watertightness	S-4	4,0
Force at break and elongation at break	S-2	6,5

## 5 Labelling

### 5.1 Use of symbols

Appropriate international symbols may be used for marking purposes in addition to the wording given in 5.2.

The language used for marking shall be as agreed upon between the interested parties.

### 5.2 Marking

Packages intended to facilitate safe transport and storage of the gloves shall be clearly marked with the following:

- a) the name or trademark of the manufacturer or supplier;
- b) the material used;
- c) the words "TEXTURED" or "SMOOTH", "PRE-POWDERED" or "POWDER-FREE", or words to that effect for the appropriate glove finish;
- d) the size, as specified in Table 1;
- e) the manufacturer's identifying lot number;
- f) the words "DATE OF MANUFACTURE", or words to that effect, and the year (in four digits) and month of manufacture;
- g) the approximate number of gloves;
- h) instructions for storage; <https://standards.iteh.ai/catalog/standards/sist/8b6ec746-f9d9-4871-a51c-efc85af577d2/iso-25518-2009>
- i) the words "NOT FOR MEDICAL OR INDUSTRIAL USE", or words to that effect.

ITIH STANDARD PREVIEW  
(standards.iteh.ai)

ISO 25518:2009

[https://standards.iteh.ai/catalog/standards/sist/8b6ec746-f9d9-4871-a51c-](https://standards.iteh.ai/catalog/standards/sist/8b6ec746-f9d9-4871-a51c-efc85af577d2/iso-25518-2009)

[efc85af577d2/iso-25518-2009](https://standards.iteh.ai/catalog/standards/sist/8b6ec746-f9d9-4871-a51c-efc85af577d2/iso-25518-2009)



## Annex A (normative)

### Test for watertightness

#### A.1 Apparatus

**A.1.1 Circular hollow mandrel**, of minimum external diameter 60 mm and adequate length to hold the glove and, with the glove attached, to accommodate 1 000 cm<sup>3</sup> of water. An example is given in Figure A.1.

NOTE A transparent circular hollow mandrel would be suitable.

Dimensions in millimetres

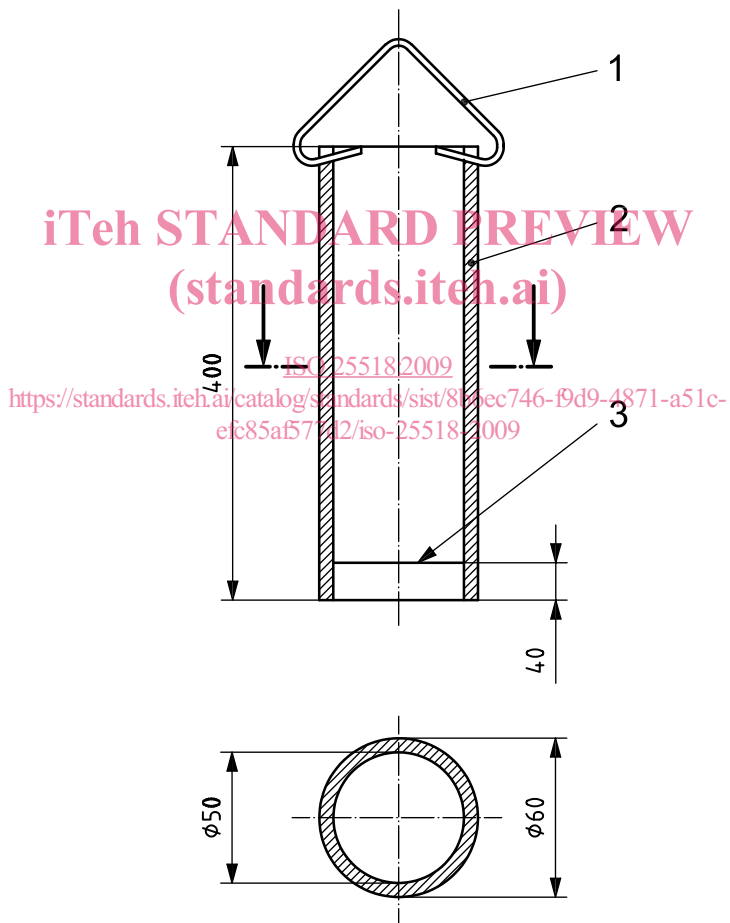

#### Key

- 1 hook
- 2 cylinder
- 3 score line on inside surface of wall

Figure A.1 — Mandrel