



SLOVENSKI STANDARD
SIST ISO 7465:2012

01-oktober-2012

Nadomešča:
SIST ISO 7465:1999

Osebna in tovorna dvigala - Vodila za kabino in protiutež - Tip T

Passenger lifts and service lifts - Guide rails for lift cars and counterweights - T-type

iTeh STANDARD PREVIEW
(standards.iteh.ai)

Ascenseurs et monte-charges - Guides de cabine et de contrepoids - Profils en T

Ta slovenski standard je istoveten z: ~~SIST ISO 7465:2007~~ ISO 7465:2007

<https://standards.iteh.ai/catalog/standards/sist/0caa46e6-b139-4821-a2e2-e19ba23761a0/sist-iso-7465-2012>

ICS:

91.140.90 Dvigala. Tekoče stopnice Lifts. Escalators

SIST ISO 7465:2012

en

iTeh STANDARD PREVIEW
(standards.iteh.ai)

SIST ISO 7465:2012

<https://standards.iteh.ai/catalog/standards/sist/0caa46e6-b139-4821-a2e2-c19ba23761a0/sist-iso-7465-2012>

INTERNATIONAL STANDARD

ISO
7465

Fourth edition
2007-11-15

Passenger lifts and service lifts — Guide rails for lift cars and counterweights — T-type

*Ascenseurs et monte-charges — Guides de cabine et de contrepoids —
Profils en T*

iTeh STANDARD PREVIEW
(standards.iteh.ai)

[SIST ISO 7465:2012](https://standards.iteh.ai/catalog/standards/sist/0caa46e6-b139-4821-a2e2-c19ba23761a0/sist-iso-7465-2012)

[https://standards.iteh.ai/catalog/standards/sist/0caa46e6-b139-4821-a2e2-
c19ba23761a0/sist-iso-7465-2012](https://standards.iteh.ai/catalog/standards/sist/0caa46e6-b139-4821-a2e2-c19ba23761a0/sist-iso-7465-2012)



Reference number
ISO 7465:2007(E)

© ISO 2007

PDF disclaimer

This PDF file may contain embedded typefaces. In accordance with Adobe's licensing policy, this file may be printed or viewed but shall not be edited unless the typefaces which are embedded are licensed to and installed on the computer performing the editing. In downloading this file, parties accept therein the responsibility of not infringing Adobe's licensing policy. The ISO Central Secretariat accepts no liability in this area.

Adobe is a trademark of Adobe Systems Incorporated.

Details of the software products used to create this PDF file can be found in the General Info relative to the file; the PDF-creation parameters were optimized for printing. Every care has been taken to ensure that the file is suitable for use by ISO member bodies. In the unlikely event that a problem relating to it is found, please inform the Central Secretariat at the address given below.

iTeh STANDARD PREVIEW (standards.iteh.ai)

[SIST ISO 7465:2012](https://standards.iteh.ai/catalog/standards/sist/0caa46e6-b139-4821-a2e2-c19ba23761a0/sist-iso-7465-2012)

<https://standards.iteh.ai/catalog/standards/sist/0caa46e6-b139-4821-a2e2-c19ba23761a0/sist-iso-7465-2012>

**COPYRIGHT PROTECTED DOCUMENT**

© ISO 2007

All rights reserved. Unless otherwise specified, no part of this publication may be reproduced or utilized in any form or by any means, electronic or mechanical, including photocopying and microfilm, without permission in writing from either ISO at the address below or ISO's member body in the country of the requester.

ISO copyright office
Case postale 56 • CH-1211 Geneva 20
Tel. + 41 22 749 01 11
Fax + 41 22 749 09 47
E-mail copyright@iso.org
Web www.iso.org

Published in Switzerland

Contents

Page

Foreword.....	iv
1 Scope	1
2 Normative references	1
3 Terms and definitions.....	1
4 Symbols and units	2
5 Manufacture and materials	3
6 Guide rails	3
6.1 Designation	3
6.2 Dimensional characteristics and tolerances	4
6.3 Marking for /BE class	14
7 Fishplates	14
7.1 Fishplate materials	14
7.2 Fishplate dimensions	14
7.3 Fishplate form tolerances	15
7.4 Fishplate holes	15
Bibliography	16

ITeH STANDARD PREVIEW
(standards.iteh.ai)

[SIST ISO 7465:2012](https://standards.iteh.ai/catalog/standards/sist/0caa46e6-b139-4821-a2e2-c19ba23761a0/sist-iso-7465-2012)

<https://standards.iteh.ai/catalog/standards/sist/0caa46e6-b139-4821-a2e2-c19ba23761a0/sist-iso-7465-2012>

ISO 7465:2007(E)

Foreword

ISO (the International Organization for Standardization) is a worldwide federation of national standards bodies (ISO member bodies). The work of preparing International Standards is normally carried out through ISO technical committees. Each member body interested in a subject for which a technical committee has been established has the right to be represented on that committee. International organizations, governmental and non-governmental, in liaison with ISO, also take part in the work. ISO collaborates closely with the International Electrotechnical Commission (IEC) on all matters of electrotechnical standardization.

International Standards are drafted in accordance with the rules given in the ISO/IEC Directives, Part 2.

The main task of technical committees is to prepare International Standards. Draft International Standards adopted by the technical committees are circulated to the member bodies for voting. Publication as an International Standard requires approval by at least 75 % of the member bodies casting a vote.

Attention is drawn to the possibility that some of the elements of this document may be the subject of patent rights. ISO shall not be held responsible for identifying any or all such patent rights.

ISO 7465 was prepared by Technical Committee ISO/TC 178, *Lifts, escalators and moving walks*.

This fourth edition cancels and replaces the third edition (ISO 7465:2001), which has been technically revised.

ITEH STANDARD PREVIEW
(standards.iteh.ai)

[SIST ISO 7465:2012](https://standards.iteh.ai/catalog/standards/sist/0caa46e6-b139-4821-a2e2-c19ba23761a0/sist-iso-7465-2012)

<https://standards.iteh.ai/catalog/standards/sist/0caa46e6-b139-4821-a2e2-c19ba23761a0/sist-iso-7465-2012>

Passenger lifts and service lifts — Guide rails for lift cars and counterweights — T-type

1 Scope

This International Standard specifies the grades and quality, the dimensional characteristics, the dimensional and geometrical tolerances, and the surface finish of standardized guide rails and their fishplates.

In addition, this International Standard defines a designation system for guide rails.

This International Standard is applicable to guide rails used in passenger lift and service lift installations to provide guiding for the car and the counterweight.

2 Normative references

The following referenced documents are indispensable for the application of this document. For dated references, only the edition cited applies. For undated references, the latest edition of the referenced document (including any amendments) applies.

ISO 1302, *Geometrical Product Specifications (GPS) — Indication of surface texture in technical product documentation*
<https://standards.iteh.ai/catalog/standards/sist/0caa46e6-b139-4821-a2e2-c19ba23761a0/sist-iso-7465-2012>

3 Terms and definitions

For the purposes of this document, the following terms and definitions apply.

3.1

guide rails

components that provide guiding for the car or the counterweight

3.2

fishplate

piece of steel used to connect the guides

ISO 7465:2007(E)

4 Symbols and units

See Table 1.

Table 1 — Symbols and corresponding units of measurement used in this International Standard

Symbol	Dimension	Unit
b_1	Guide rail width	mm
b_2	Fishplate width	mm
b_3	Distance between the axes of the holes (in the transverse direction of the guide and of the fishplate)	mm
c	Width of the connecting part of the foot to the blade	mm
d	Hole diameter	mm
d_1	Countersink diameter	mm
e	Distance from the rear surface to the centre of gravity of the guide rail	cm
f	Foot depth at its connection with the blade	mm
g	Foot depth at its extremity in a transverse plane	mm
h	Guide height at the level of the machined surface for the location of the fishplate	mm
h_1	Guide rail height (for cold-drawn guide rail or on non-machined surface)	mm
I_{x-x}	Moment of inertia of the cross-sectional area of the guide rail related to the x-x axis	cm ⁴
I_{y-y}	Moment of inertia of the cross-sectional area of the guide rail related to the y-y axis	cm ⁴
i_{x-x}	Radius of gyration corresponding to the x-x axis	cm
i_{y-y}	Radius of gyration corresponding to the y-y axis	cm
k	Blade width	mm
l	Machined surface length for the location of the fishplate	mm
l_1	Fishplate length	mm
l_{2g}	Distance, in the guide rail longitudinal direction, between the axis of the farthest holes from the end of the guide rail and this end	mm
l_{2f}	Distance, in the fishplate longitudinal direction, between the axis of the farthest holes from the transverse axis of the fishplate and this axis	mm
l_{3g}	Distance, in the guide rail longitudinal direction, between the axis of the nearest holes to the end of the guide rail and this end	mm
l_{3f}	Distance, in the fishplate longitudinal direction, between the axis of the nearest holes to the transverse axis of the fishplate and this axis	mm
l_g	Length of the guide rail	mm
l_m	Maximum length for the junction area between the machined surface for the fishplate and the non-machined surface	mm
m_1	Width of the keyway for the junction of the guide rails	mm
m_2	Width of the key for the junction of the guide rails	mm
n	Blade height	mm
p	Foot depth (in the case of a flat foot)	mm
q_1	Linear density for a finished guide rail	kg/m

Table 1 (continued)

Symbol	Dimension	Unit
R_a	Surface roughness (see ISO 1302)	μm
r_s	Foot radius	mm
S	Cross-sectional area of the guide rail	cm^2
t_n	t_1 to t_n : Tolerances for geometrical dimensions	mm
u_1	Depth of the keyway for the junction of the guides rails	mm
u_2	Length of the key for the junction of the guides rails	mm
v	Fishplate thickness (when machined)	mm
W_{x-x}	Cross-sectional area modulus related to the x-x axis	cm^3
W_{y-y}	Cross-sectional area modulus related to the y-y axis	cm^3

5 Manufacture and materials

Guide rails may be cold drawn or machined. In this International Standard, the manufacturing process for each type of guide is indicated by the symbol /A for “cold drawn”, the symbol /B for “machined”, and the symbol /BE for “machined high quality”.

The tensile strength of the raw material used (steel) shall be at least 370 N/mm² and not more than 520 N/mm². For this purpose, it is recommended to use steel grade E 235 B for cold-drawn guide rails and steel grade E 275 B for machined guides, in accordance with ISO 630:1995.

[SIST ISO 7465:2012](https://standards.iteh.ai/catalog/standards/sist/0caa46e6-b139-4821-a2e2-c19ba23761a0/sist-iso-7465-2012)

<https://standards.iteh.ai/catalog/standards/sist/0caa46e6-b139-4821-a2e2-c19ba23761a0/sist-iso-7465-2012>

6 Guide rails

6.1 Designation

Guide rails complying with the requirements of this International Standard shall be designated as follows:

- 1st element: Number of this International Standard, followed by a hyphen: ISO 7465-;
- 2nd element: Guide rail shape: T;
- 3rd element: Rounded value of the foot width with, if necessary, the number of the variant for different profiles with the same foot width: 45; 50; 70; 75; 78; 82; 89; 90; 114; 125; 127-1; 127-2; 140-1; 140-2; 140-3;
- 4th element: Manufacturing process:
 - cold drawn: /A;
 - machined: /B;
 - machined high quality types: /BE.

EXAMPLE 1 Lift guide rail ISO 7465-T82/A.

EXAMPLE 2 Lift guide rail ISO 7465-T125/BE.

EXAMPLE 3 Lift guide rail ISO 7465-T140-1/B.

ISO 7465:2007(E)

6.2 Dimensional characteristics and tolerances

6.2.1 Length

The length of the guide rail shall be indicated in millimetres, with a tolerance of ± 2 mm. It is recommended to supply bars of 5 000 mm length.

6.2.2 Dimensions

See Tables 2 to 7.

Two series of dimensions are proposed:

— preferred dimensions, designated without round brackets;

EXAMPLE T82/A.

— non-preferred dimensions, designated within round brackets.

EXAMPLE (T89/A).

Guide rails with other dimensions can be delivered on specific agreement between the guide rails manufacturer and the customer.

6.2.2.1 Cold-drawn, parallel foot-and-blade flange guide rail

See Figure 1 and Tables 2 and 3.

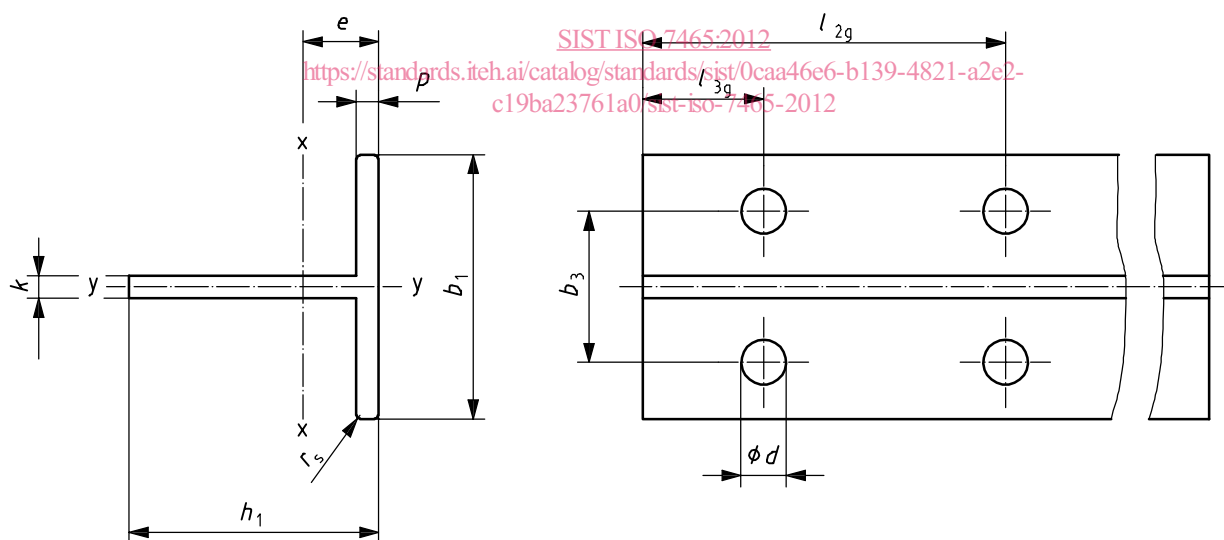

Figure 1 — Cold-drawn, parallel foot-and-blade flange guide rail

Table 2 — Technical characteristics of cold-drawn, parallel foot-and-blade flange guide rails (see Figure 1)

Designation	S	q_1	e	I_{x-x}	W_{x-x}	i_{x-x}	I_{y-y}	W_{y-y}	i_{y-y}
	cm ²	kg/m	cm	cm ⁴	cm ³	cm	cm ⁴	cm ³	cm
(T45/A)	4,25	3,34	1,31	8,08	2,53	1,38	3,84	1,71	0,95
T50/A	4,75	3,73	1,43	11,24	3,15	1,54	5,25	2,1	1,05

Table 3 — Dimensions and tolerances of cold-drawn, parallel foot-and-blade flange guide rails
(see Figure 1)

Dimensions in millimetres

Designation	b_1	h_1	k	p	r_s	l_{2g}	l_{3g}	d	b_3
(T45/A)	45	45	5	5	1	65	15	9	25
T50/A	50	50	5	5	1	75	25	9	30
Tolerances	± 1	$\pm 0,2$	$\pm 0,15$	$\pm 0,5$	—	$\pm 0,2$	$\pm 0,2$	—	$\pm 0,2$

NOTE Dimensions l_{2g} , l_{3g} , d , b_3 are identical to and have the same tolerances as fishplate dimensions l_{2f} , l_{3f} , d , b_3 .

6.2.2.2 Cold-drawn, inclined-foot flange guide rail

See Figure 2 and Tables 4 and 5.

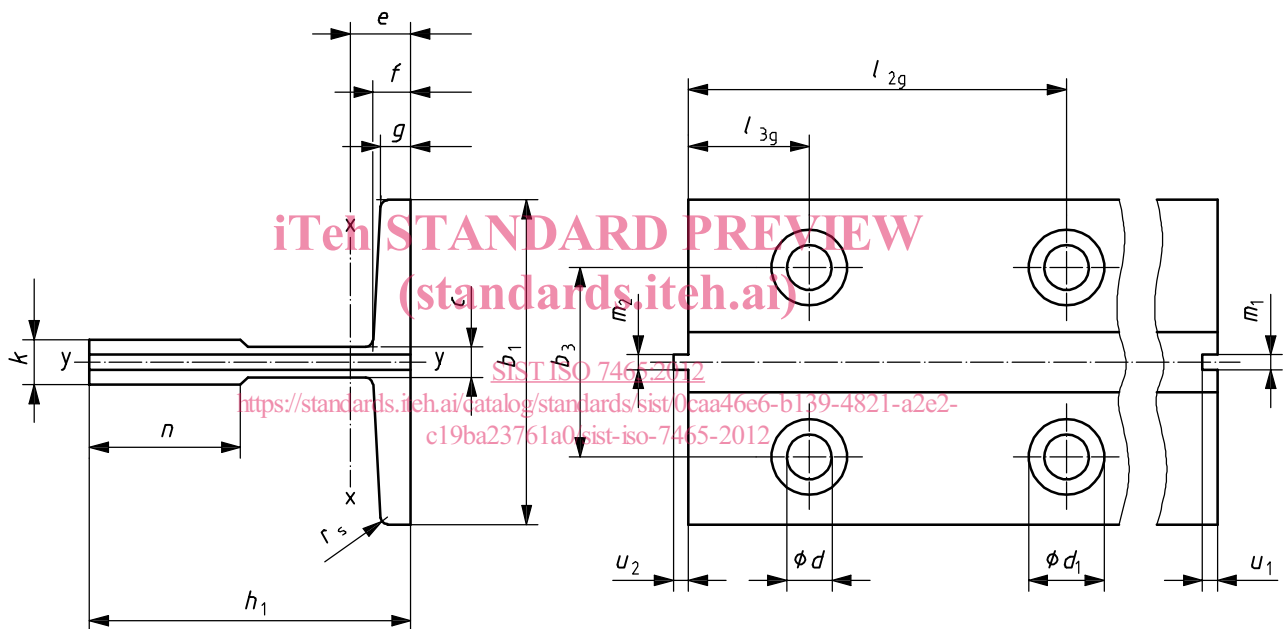

Figure 2 — Cold-drawn, inclined-foot flange guide rail

Table 4 — Technical characteristics of cold-drawn, inclined-foot flange guide rails
(see Figure 2)

Designation	S	q_1	e	I_{x-x}	W_{x-x}	i_{x-x}	I_{y-y}	W_{y-y}	i_{y-y}
	cm ²	kg/m	cm	cm ⁴	cm ³	cm	cm ⁴	cm ³	cm
T70/A	9,400	7,379	2,034	40,95	9,169	2,087	18,86	5,389	1,417
(T75/A)	10,91	8,564	1,861	40,29	9,286	1,921	26,47	7,060	1,557
T82/A	10,91	8,564	1,998	49,31	10,27	2,126	30,17	7,358	1,663
(T89/A)	15,77	12,38	2,032	59,83	14,35	1,948	52,41	11,78	1,823
(T90/A)	17,25	13,54	2,612	102,00	20,86	2,431	52,48	11,66	1,744