



Designation: E 948 – 05a

# Standard Test Method for Electrical Performance of Photovoltaic Cells Using Reference Cells Under Simulated Sunlight<sup>1</sup>

This standard is issued under the fixed designation E 948; the number immediately following the designation indicates the year of original adoption or, in the case of revision, the year of last revision. A number in parentheses indicates the year of last reapproval. A superscript epsilon ( $\epsilon$ ) indicates an editorial change since the last revision or reapproval.

## 1. Scope

1.1 This test method covers the determination of the electrical performance of a photovoltaic cell under simulated sunlight by means of a calibrated reference cell procedure.

1.2 Electrical performance measurements are reported with respect to a select set of standard reporting conditions (SRC) (see Table 1) or to user-specified conditions.

1.2.1 The SRC or user-specified conditions include the cell temperature, the total irradiance, and the reference spectral irradiance distribution.

1.3 This test method is applicable only to photovoltaic cells with a linear response over the range of interest.

1.4 The cell parameters determined by this test method apply only at the time of test, and imply no past or future performance level.

1.5 *This standard does not purport to address all of the safety concerns, if any, associated with its use. It is the responsibility of the user of this standard to establish appropriate safety and health practices and determine the applicability of regulatory limitations prior to use.*

## 2. Referenced Documents

2.1 *ASTM Standards:*<sup>2</sup>

E 490 Solar Constant and Zero Air Mass Solar Spectral Irradiance Tables

E 491 Practice for Solar Simulation for Thermal Balance Testing of Spacecraft

E 691 Practice for Conducting an Interlaboratory Study to Determine the Precision of a Test Method

E 772 Terminology Relating to Solar Energy Conversion

E 927 Specification for Solar Simulation for Terrestrial Photovoltaic Testing

E 973 Test Method for Determination of the Spectral Mismatch Parameter Between a Photovoltaic Device and a

TABLE 1 Standard Reporting Conditions

Reference Spectral Irradiance Distribution	Total Irradiance ( $\text{Wm}^{-2}$ )	Temperature ( $^{\circ}\text{C}$ )
Tables G 173 Direct Normal	1000	25
Tables G 173 Hemispherical	1000	25
Tables E 490	1366.1	25

Photovoltaic Reference Cell

E 1039 Test Method for Calibration of Silicon Non-Concentrator Photovoltaic Primary Reference Cells Under Global Irradiation

E 1125 Test Method for Calibration of Primary Non-Concentrator Terrestrial Photovoltaic Reference Cells Using a Tabular Spectrum

E 1328 Terminology Relating to Photovoltaic Solar Energy Conversion

E 1362 Test Method for Calibration of Non-Concentrator Photovoltaic Secondary Reference Cells

G 173 Tables for Reference Solar Spectral Irradiances: Direct Normal and Hemispherical on  $37^{\circ}$  Tilted Surface

## 3. Terminology

3.1 *Definitions*—Definitions of terms in this test method may be found in Terminology E 772 and Terminology E 1328.

3.2 *Definitions of Terms Specific to This Standard:*

3.2.1 *cell temperature,  $^{\circ}\text{C}$ ,  $n$* —the temperature of the semiconductor junction of a photovoltaic cell.

3.2.2 *junction temperature,  $n$* —synonym for *cell temperature*.

3.2.3 *light source,  $n$* —a source of radiant energy used for cell performance measurements that simulates natural sunlight.

3.3 *Symbols:* Symbols:

3.3.1 The following symbols and units are used in this test method:

$A$ —cell area,  $\text{m}^2$

$\alpha_r$ —temperature coefficient of reference cell,  $^{\circ}\text{C}^{-1}$

$C$ —calibration constant of reference cell,  $\text{Am}^2\text{W}^{-1}$

$E$ —irradiance,  $\text{Wm}^{-2}$

$E_o$ —standard reporting irradiance,  $\text{Wm}^{-2}$

$\eta$ —efficiency, %

$FF$ —fill factor, %

$I$ —current, A

$I_o$ —current with respect to SRC, A

<sup>1</sup> This test method is under the jurisdiction of ASTM Committee E44 on Solar, Geothermal and Other Alternative Energy Sources and is the direct responsibility of Subcommittee E44.09 on Photovoltaic Electric Power Conversion.

Current edition approved Sept. 1, 2005. Published October 2005. Originally approved in 1993. Last previous edition approved in 2005 as E 948–05.

<sup>2</sup> For referenced ASTM standards, visit the ASTM website, www.astm.org, or contact ASTM Customer Service at service@astm.org. For *Annual Book of ASTM Standards* volume information, refer to the standard's Document Summary page on the ASTM website.

- $I_r$ —reference cell short-circuit current, A
- $I_{sc}$ —short-circuit current, A
- $M$ —spectral mismatch parameter
- $P_m$ —maximum power, W
- $R_s$ —series resistance,  $\Omega$
- $T$ —temperature,  $^{\circ}\text{C}$
- $T_o$ —standard reporting temperature,  $^{\circ}\text{C}$
- $T_r$ —temperature of reference cell,  $^{\circ}\text{C}$
- $V$ —voltage, V
- $V_o$ —voltage with respect to SRC, V
- $V_{oc}$ —open-circuit voltage, V

**4. Summary of Test Method**

4.1 The performance test of a photovoltaic cell consists of measuring the electrical current versus voltage (I-V) characteristic of the cell while illuminated by a suitable light source.

4.2 A calibrated photovoltaic reference cell (see 6.1) is used to determine the total irradiance during the test and to account for the spectral distribution of the light source.

4.3 Simulated sunlight is used as the light source for the electrical performance measurement, and solar simulation requirements are defined in Specification E 927 (terrestrial applications) and Practice E 491 (space applications).

4.4 The data from the measurements are corrected to standard reporting conditions, or to optional user-specified reporting conditions. The standard reporting conditions are defined in Table 1.<sup>3</sup>

4.4.1 Measurement error caused by deviations of the irradiance conditions from the SRC is corrected using the total irradiance measured with the reference cell and the spectral mismatch parameter,  $M$ , which is determined in accordance with Test Method E 973.

4.4.2 Measurement error caused by deviation of the cell temperature from the SRC is minimized by maintaining the cell temperature close to the required value (see 7.6.1).

**5. Significance and Use**

5.1 It is the intent of this test method to provide a recognized method for testing and reporting the electrical performance of photovoltaic cells.

5.2 The test results may be used for comparison of cells among a group of similar cells or to compare diverse designs, such as different manufacturers' products. Repeated measurements of the same cell may be used to study changes in device performance.

5.3 This test method determines the electrical performance of a cell based upon the output power at a single instant of time. It does not provide for integrating the output power over a given period of time and conditions to predict an energy output.

5.4 This test method requires a reference cell calibrated with respect to an appropriate reference spectral irradiance distribution, such as Tables E 490, or G 173. It is the responsibility of

the user to determine which reference spectral irradiance distribution is appropriate for a particular application.

**6. Apparatus**

6.1 *Photovoltaic Reference Cell*—A calibrated reference cell is used to determine the total irradiance during the electrical performance measurement.

6.1.1 Reference cells may be calibrated in accordance with Test Methods E 1039, E 1125, or E 1362, as is appropriate for a particular application.

NOTE 1—No reference cell calibration standards presently exist for space applications, although procedures such as high-altitude balloon and low-earth orbit flights are being used to calibrate such reference cells.

6.1.2 A current measurement instrument (see 6.3) shall be used to determine the  $I_{sc}$  of the reference cell under the light source.

6.2 *Test Fixture*— Both the cell to be tested and the reference cell are mounted in a fixture that meets the following requirements.

6.2.1 The test fixture shall ensure a uniform lateral temperature distribution to within  $\pm 0.5^{\circ}\text{C}$  during the performance measurement.

6.2.2 The test fixture shall include a provision for maintaining a constant cell temperature for both the reference cell and the cell to be tested (see 7.6.1).

NOTE 2—When using pulsed or shuttered light sources, it is possible that the cell temperature will increase upon initial illumination, even when the cell temperature is controlled.

6.2.3 The test fixture, when placed in the simulated sunlight, shall ensure that the field-of-view of both the reference cell and the cell to be tested are identical.

NOTE 3—Some solar simulators may have significant amounts of irradiation from oblique or non-perpendicular angles to the test plane. In these cases, it is important that the cell to be tested and the reference cell have similar reflectance and cosine-response characteristics.

6.2.4 A four-terminal connection (also known as a Kelvin connection, see Fig. 1) from the cell to be tested to the I-V measurement instrumentation (see 6.3-6.5) shall be used.

6.3 *Current Measurement Equipment*— The instrument or instruments used to measure the cell current and the  $I_{sc}$  of the

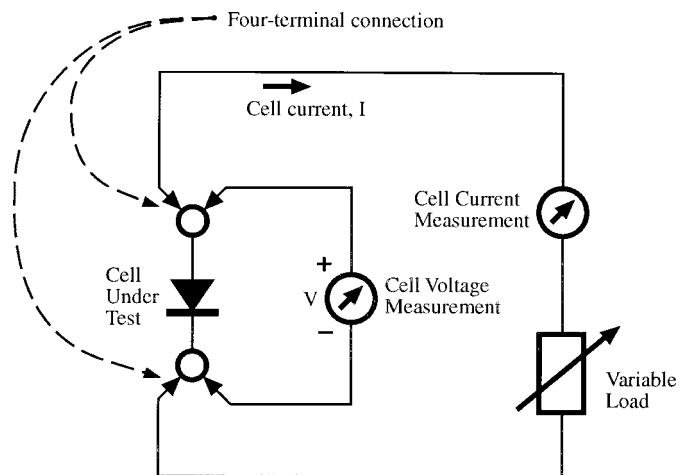

FIG. 1 I-V Measurement Schematic

<sup>3</sup> Wehrli, C., Extraterrestrial Solar Spectrum, Publ. No. 615, Physikalisch-Meteorologisches Observatorium and World Radiation Center, Davos Switzerland, 1985.

reference cell shall have a resolution of at least 0.02 % of the maximum current encountered, and shall have a total error of less than 0.1 % of the maximum current encountered.

6.4 *Voltage Measurement Equipment*—The instrument or instruments used to measure the cell voltage shall have a resolution of at least 0.02 % of the maximum voltage encountered, and shall have a total error of less than 0.1 % of the maximum voltage encountered.

6.5 *Variable Load*—An electronic load, such as a variable resistor or a programmable power supply, used to operate the cell to be tested at different points along its I-V characteristic.

6.5.1 The variable load shall be capable of operating the cell to be tested at an I-V point where the voltage is within 1 % of  $V_{oc}$  in the power-producing quadrant.

6.5.2 The variable load shall be capable of operating the cell to be tested at an I-V point where the current is within 1 % of  $I_{sc}$  in the power-producing quadrant.

6.5.3 The variable load must allow an output power (the product of cell current and cell voltage) resolution of at least 0.2 % of the maximum power.

6.5.4 The electrical response time of the variable load must be fast enough to sweep the range of I-V operating points during the measurement period.

NOTE 4—It is possible that the response time of cell to be tested may limit how fast the range of I-V operating points can be swept, especially when pulsed solar simulators are used. For these cases, it may be necessary to measure smaller ranges of the I-V curve using multiple measurements to obtain the entire range required.

6.6 *Light Source*—Requirements of the solar simulation used to illuminate the cell to be tested are defined in Specification E 927 (terrestrial applications) and Practice E 491 (space applications).

6.7 *Temperature Measurement Equipment*—The instrument or instruments used to measure the cell temperature of both the reference cell and the cell to be tested shall have a resolution of at least 0.1°C, and shall have a total error of less than ±1°C of reading.

6.7.1 Sensors used for the temperature measurement(s) must be located in a position that minimizes any temperature gradients between the sensor and the photovoltaic device junction.

## 7. Procedure

7.1 Determine the series resistance,  $R_s$ , of the cell to be measured. An acceptable method is described in Annex A1.

7.1.1 If the total irradiance during the performance measurement as measured by the reference cell is within ±2 % of the standard reporting total irradiance, the series resistance is not needed.

7.2 Measure the cell area,  $A$ , using the definition in Terminology E 1328.

7.3 Determine the spectral mismatch parameter,  $M$ , using Test Method E 973.

7.4 Mount the cell to be tested and the reference cell in the test fixture.

NOTE 5—Any nonuniformity of irradiance (see Specification E 927) between the locations of the reference cell and the cell to be tested will introduce a bias error in the measured cell performance.

7.4.1 If a pulsed or shuttered light source is used, expose the test fixture to the source illumination.

7.5 Measure the temperature of the reference cell,  $T_r$ .

7.5.1 If the temporal instability of the light source (as defined in Specification E 927) is less than 0.1 %, the total irradiance may be determined with the reference cell prior to the performance measurement. In this case, use the following steps to measure the total irradiance.

7.5.1.1 Measure the short-circuit current of the reference cell,  $I_r$ .

7.5.1.2 Replace the reference cell with the cell to be tested.

7.6 Measure the temperature of the cell under test.

7.6.1 The measured temperature of the cell under test shall be within ±1°C of the applicable SRC.

7.7 Measure the I-V characteristic of the cell under test by changing the operating point with the variable load so that the provisions of 6.5.1-6.5.3 are met. At each operating point on the I-V characteristic, measure the cell voltage, cell current, and the  $I_{sc}$  of the reference cell.

7.7.1 If the provision of 7.7 is met, it is not necessary to measure the  $I_{sc}$  of the reference cell at the same time that the I-V characteristic is measured.

7.8 Measure the temperature of the cell under test to verify that the provision in 7.6.1 is met.

## 8. Calculation

8.1 Obtain the temperature coefficient of the reference cell from the calibration report.

8.2 Correct each I-V data pair using the following equations:

$$I_o = \frac{IE_oC}{MI_r[1 - \alpha_r(T_o - T_r)]} \quad (1)$$

$$V_o = V - R_s(I_o - I) \quad (2)$$

NOTE 6—If the provision of 7.1.1 is met, it is not necessary to correct the cell voltage using the series resistance.

8.3 Determine the short-circuit current using one of the following procedures:

8.3.1 If an  $I_o - V_o$  data pair exists where  $V_o$  is within ±0.005 $V_{oc}$ ,  $I_o$  from this pair may be considered to be the short-circuit current.

8.3.2 If the condition in 8.3.1 is not met, calculate the short-circuit current from the two  $I_o - V_o$  data pairs where  $V_o$  is closest to zero using linear interpolation.

8.4 Determine the open-circuit voltage using one of the following procedures:

8.4.1 If an  $I_o - V_o$  data pair exists where  $I_o$  is within ±0.001 $I_{sc}$ ,  $V_o$  from this pair may be considered to be the open-circuit voltage.

8.4.2 If the condition in 8.4.1 is not met, calculate the open-circuit voltage from the two  $I_o - V_o$  data pairs where  $I_o$  is closest to zero using linear interpolation.

8.5 Calculate the cell output power  $P$  for each data pair from the product of  $I_o$  and  $V_o$ , and determine the maximum power point  $P_m$  along with the corresponding  $V_m$  from the  $P$  vs.  $V_o$  table. Because of random fluctuations and the probability that one point in the tabular I-V data will not be exactly on the maximum power point, it is recommended that the following