INTERNATIONAL STANDARD



355

INTERNATIONAL ORGANIZATION FOR STANDARDIZATION • МЕЖДУНАРОДНАЯ ОРГАНИЗАЦИЯ ПО СТАНДАРТИЗАЦИИ • ORGANISATION INTERNATIONALE DE NORMALISATION

Rolling bearings — Metric tapered roller bearings — Boundary dimensions and series designations

Roulements — Roulements à rouleaux coniques métriques — Dimensions d'encombrement et désignation des séries

iTeh STANDARD PREVIEW

First edition — 1977-05-01

(standards.iteh.ai)

ISO 355:1977

<https://standards.iteh.ai/catalog/standards/sist/e29803b3-e05f-4249-ac17-e15e10c73406/iso-355-1977>

UDC 621.822.87

Ref. No. ISO 355-1977 (E)

Descriptors : rolling bearings, roller bearings, taper roller bearings, specifications, dimensions, designations.

FOREWORD

ISO (the International Organization for Standardization) is a worldwide federation of national standards institutes (ISO member bodies). The work of developing International Standards is carried out through ISO technical committees. Every member body interested in a subject for which a technical committee has been set up has the right to be represented on that committee. International organizations, governmental and non-governmental, in liaison with ISO, also take part in the work.

Draft International Standards adopted by the technical committees are circulated to the member bodies for approval before their acceptance as International Standards by the ISO Council.

International Standard ISO 355 was developed by Technical Committee ISO/TC 4, *Rolling bearings*, and was circulated to the member bodies in December 1975.

It has been approved by the member bodies of the following countries :

Australia	Italy	ISO 355:1977
Austria	Japan	Switzerland
Brazil	Mexico	Turkey
Canada	Poland	United Kingdom
Czechoslovakia	Romania	U.S.A.
Germany	South Africa, Rep. of	U.S.S.R.
Hungary	Spain	Yugoslavia
India	Sweden	

The member body of the following country expressed disapproval of the document on technical grounds :

France

This International Standard cancels and replaces ISO Recommendations R 355 Parts I to VII and International Standard ISO 355/VIII, of which documents it constitutes a technical revision.

Rolling bearings – Metric tapered roller bearings – Boundary dimensions and series designations

iTeh STANDARD PREVIEW (standards.iteh.ai)

1 SCOPE AND FIELD OF APPLICATION

This International Standard specifies bearing and sub-unit boundary dimensions for single-row metric tapered roller bearings.

It also specifies a series designation for each bearing. The designation system shown in clause 3 shall not be applied

to bearings not included in clause 4 of this International Standard.

Tolerances for the dimensions are given in separate ISO publications.

For front face chamfers r_5 , no dimensions are given in this International Standard; however, the front face corners should not be sharp.

2 SYMBOLS

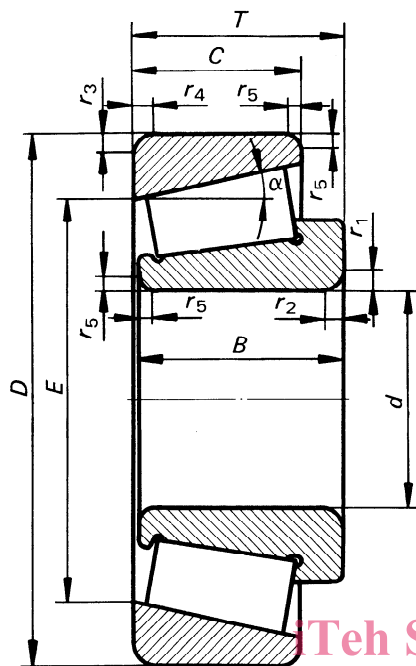

- d = bearing bore diameter, nominal
- D = bearing outside diameter, nominal
- T = bearing width, nominal
- B = cone width, nominal
- C = cup width, nominal
- E = cup small inside diameter, nominal
- α = bearing contact angle, nominal
- r_1 = cone back face chamfer height
- $r_{1\text{min}}$ = smallest single r_1
- r_2 = cone back face chamfer width
- $r_{2\text{min}}$ = smallest single r_2
- r_3 = cup back face chamfer height
- $r_{3\text{min}}$ = smallest single r_3
- r_4 = cup back face chamfer width
- $r_{4\text{min}}$ = smallest single r_4
- r_5 = cone and cup front face chamfer height and width (see clause 1)

3 SERIES DESIGNATIONS

Each bearing, the dimensions of which are given in this International Standard, is referred to a dimension series. The dimension series is designated by a combination of three symbols, for example 2AC.

The first symbol is a numeric character, which represents a range of contact angles, angle series.

The second symbol is an alphabetic character, which represents a range of numeric values for the outside diameter to bore relationship, diameter series.

The third symbol is an alphabetic character, which represents a range of numeric values for the width to section height relationship, width series.

TABLE 1 – Series designation

Angle series designation	α	
	Over	Incl.
1	Reserved for future use	
2	10°	13° 52'
3	13° 52'	15° 59'
4	15° 59'	18° 55'
5	18° 55'	23°
6	23°	27°
7	27°	30°

Diameter series designation	$\frac{D}{d^{0,77}}$	
	Over	Incl.
A	Reserved for future use	
B	3,40	3,80
C	3,80	4,40
D	4,40	4,70
E	4,70	5,00
F	5,00	5,60
G	5,60	7,00

Width series designation	$\frac{T}{(D-d)^{0,95}}$	
	Over	Incl.
A	Reserved for future use	
B	0,50	0,68
C	0,68	0,80
D	0,80	0,88
E	0,88	1,00

The designations for the standardized bearings conform generally with the angle ranges and the numeric values for the relationships given in table 1. In some cases an exception has been made to avoid the condition that the same designation be used for two different bearings with the same bore diameter.

4 BOUNDARY DIMENSIONS

In tables 2 to 6, bearing and sub-unit boundary dimensions have been grouped by contact angle series and then listed in ascending order of bore, outside diameter and bearing width.

TABLE 2 – Contact angle series 2

Values in millimetres and degrees

d	D	T	B	r_{1smin} r_{2smin}	C	r_{3smin} r_{4smin}	α	E	Dimension series
15	42	14,25	13	1	11	1	10° 45' 29''	33,272	2FB
17	40	13,25	12	1	11	1	12° 57' 10''	31,408	2DB
17	40	17,25	16	1	14	1	11° 45'	31,170	2DD
17	47	15,25	14	1	12	1	10° 45' 29''	37,420	2FB
17	47	20,25	19	1	16	1	10° 45' 29''	36,090	2FD
20	37	12	12	0,3	9	0,3	12°	29,621	2BD
20	45	17	17,5	1	13,5	1	12°	35,815	2DC
20	47	15,25	14	1	12	1	12° 57' 10''	37,304	2DB
20	47	19,25	18	1	15	1	12° 28'	35,810	2DD
20	50	22	22	2	18,5	1,5	12° 30'	38,063	2ED
20	52	16,25	15	1,5	13	1,5	11° 18' 36''	41,318	2FB
20	52	22,25	21	1,5	18	1,5	11° 18' 36''	39,518	2FD
22	40	12	12	0,3	9	0,3	12°	32,665	2BC
22	47	17	17,5	1	13,5	1	12° 35'	37,542	2CC
22	52	22	22	2	18,5	1,5	12° 14'	40,548	2ED
25	42	12	12	0,3	9	0,3	12°	34,608	2BD
25	47	17	17,5	0,6	14	0,6	10° 55'	38,278	2CE
25	50	17	17,5	1,5	13,5	1	13° 30'	40,205	2CC
25	52	19,25	18	1	16	1	13° 30'	41,331	2CD
25	52	22	22	1	18	1	13° 10'	40,441	2DE
25	58	26	26	2	21	1,5	12° 30'	44,805	2EE
25	62	18,25	17	1,5	15	1,5	11° 18' 36''	50,637	2FB
25	62	25,25	24	1,5	20	1,5	11° 18' 36''	48,637	2FD
28	45	12	12	0,3	9	0,3	12°	37,639	2BD
28	55	19	19,5	1,5	15,5	1,5	12° 10'	44,888	2CD
28	58	24	24	1	19	1	12° 45'	45,846	2DE
28	65	27	27	2	22	2	12° 45'	50,330	2ED
30	47	12	12	0,3	9	0,3	12°	39,617	2BD
30	55	20	20	1	16	1	11°	45,283	2CE
30	58	19	19,5	1,5	15,5	1,5	12° 50'	47,309	2CD
30	62	25	25	1	19,5	1	12° 50'	49,524	2DE
30	68	29	29	2	24	2	12° 28'	52,696	2EE
30	72	20,75	19	1,5	16	1,5	11° 51' 35''	58,287	2FB
30	72	28,75	27	1,5	23	1,5	11° 51' 35''	55,767	2FD
32	52	14	15	0,6	10	0,6	12°	44,261	2BD
32	62	21	21	1,5	17	1,5	12° 30'	50,554	2CD
32	65	26	26	1	20,5	1	13°	51,791	2DE
32	72	29	29	2	24	2	12° 41' 30''	56,151	2ED
35	55	14	14	0,6	11,5	0,6	11°	47,220	2BD
35	62	21	21	1	17	1	11° 30'	51,320	2CE
35	68	23	23	2	18,5	2	12° 35'	55,400	2DD
35	72	28	28	1,5	22	1,5	13° 15'	57,186	2DE
35	78	33	32,5	2,5	27	2	12° 12'	61,925	2EE
35	80	22,75	21	2	18	1,5	11° 51' 35''	65,769	2FB
35	80	32,75	31	2	25	1,5	11° 51' 35''	62,829	2FE

TABLE 2 (continued)

Values in millimetres and degrees

d	D	T	B	$r_{1\text{min}}$ $r_{2\text{min}}$	C	$r_{3\text{min}}$ $r_{4\text{min}}$	α	E	Dimension series
40	62	15	15	0,6	12	0,6	10° 55'	53,388	2BC
40	68	22	22	1	18	1	10° 40'	57,290	2BE
40	75	24	24	2	19,5	2	12° 07'	62,155	2CD
40	75	26	26	1,5	20,5	1,5	13° 20'	61,169	2CE
40	80	32	32	1,5	25	1,5	13° 25'	63,405	2DE
40	85	33	32,5	2,5	28	2	12° 55'	66,612	2EE
40	90	25,25	23	2	20	1,5	12° 57' 10''	72,703	2FB
40	90	35,25	33	2	27	1,5	12° 57' 10''	69,253	2FD
45	68	15	15	0,6	12	0,6	12°	58,852	2BC
45	75	24	24	1	19	1	11° 05'	63,116	2CE
45	80	24	24	2	19,5	2	13°	66,615	2CD
45	95	36	35	2,5	30	2,5	12° 09'	75,712	2ED
45	100	27,25	25	2	22	1,5	12° 57' 10''	81,780	2FB
45	100	38,25	36	2	30	1,5	12° 57' 10''	78,330	2FD
50	72	15	15	0,6	12	0,6	12° 50'	62,748	2BC
50	80	24	24	1	19	1	11° 55'	67,775	2CE
50	85	24	24	2	19,5	2	13° 52'	70,969	2CD
50	100	36	35	2,5	30	2,5	12° 51'	79,996	2ED
50	110	29,25	27	2,5	23	2	12° 57' 10''	90,633	2FB
50	110	42,25	40	2,5	33	2	12° 57' 10''	86,263	2FD
55	80	17	17	1	14	1	11° 39'	69,503	2BC
55	85	18	18,5	2	14	2	12° 49'	73,586	2CC
55	90	27	27	1,5	21	1,5	11° 45'	76,656	2CE
55	95	27	27	2	21,5	2	12° 43' 30''	80,106	2CD
55	110	39	39	2,5	32	2,5	13°	88,446	2ED
55	120	31,5	29	2,5	25	2	12° 57' 10''	99,146	2FB
55	120	45,5	43	2,5	35	2	12° 57' 10''	94,316	2FD
60	85	17	17	1	14	1	12° 27'	74,185	2BC
60	90	18	18,5	2	14	2	13° 38' 30''	78,249	2CC
60	95	27	27	1,5	21	1,5	12° 20'	80,422	2CE
60	100	27	27	2	21,5	2	13° 27'	84,587	2CD
60	115	40	39	2,5	33	2,5	12° 30'	93,460	2EE
60	130	33,5	31	3	26	2,5	12° 57' 10''	107,769	2FB
60	130	48,5	46	3	37	2,5	12° 57' 10''	102,939	2FD
65	90	17	17	1	14	1	13° 15'	78,849	2BC
65	100	22	22	2	17,5	2	12° 10' 30''	87,433	2CC
65	100	27	27	1,5	21	1,5	13° 05'	85,257	2CE
65	110	31	31	2	25	2	12° 27'	93,090	2DD
65	125	43	42	2,5	35	2,5	12°	102,378	2FD
65	140	36	33	3	28	2,5	12° 57' 10''	116,846	2GB
65	140	51	48	3	39	2,5	12° 57' 10''	111,786	2GD
70	100	20	20	1	16	1	11° 53'	88,590	2BC
70	105	22	22	2	17,5	2	12° 49' 30''	92,004	2CC
70	110	31	31	1,5	25,5	1,5	10° 45'	95,021	2CE
70	120	34	33	2	27	2	12° 22'	101,343	2DD
70	130	43	42	3	35	2,5	12° 31' 30''	106,766	2ED
70	150	38	35	3	30	2,5	12° 57' 10''	125,244	2GB
70	150	54	51	3	42	2,5	12° 57' 10''	119,724	2GD

TABLE 2 (continued)

Values in millimetres and degrees

<i>d</i>	<i>D</i>	<i>T</i>	<i>B</i>	<i>r</i> _{1smin} <i>r</i> _{2smin}	<i>C</i>	<i>r</i> _{3smin} <i>r</i> _{4smin}	<i>α</i>	<i>E</i>	Dimension series
75	105	20	20	1	16	1	12° 31'	93,223	2BC
75	115	25	25	2	20	2	12°	100,414	2CC
75	115	31	31	1,5	25,5	1,5	11° 15'	99,400	2CE
75	125	34	33	2,5	27	2	12° 55'	105,786	2DD
75	135	43	42	3	35	2,5	13° 03'	111,153	2ED
75	160	40	37	3	31	2,5	12° 57' 10"	134,097	2GB
75	160	58	55	3	45	2,5	12° 57' 10"	127,887	2GD
80	110	20	20	1	16	1	13° 10'	97,974	2BC
80	120	25	25	2	20	2	12° 33' 30"	105,003	2CC
80	125	36	36	1,5	29,5	1,5	10° 30'	107,750	2CE
80	130	34	33	2,5	27	2	13° 30'	110,475	2DD
80	145	46	45	3	38	2,5	12° 02'	120,366	2ED
80	170	42,5	39	3	33	2,5	12° 57' 10"	143,174	2GB
80	170	61,5	58	3	48	2,5	12° 57' 10"	136,504	2GD
85	120	23	23	1,5	18	1,5	12° 18'	106,599	2BC
85	125	25	25	2,5	20	2	13° 7' 30"	109,650	2CC
85	130	36	36	1,5	29,5	1,5	11°	112,838	2CE
85	135	34	33	2,5	28	2	13° 02'	115,904	2DD
85	150	46	46	3	38	3	12° 30'	124,965	2ED
85	180	44,5	41	4	34	3	12° 57' 10"	150,433	2GB
85	180	63,5	60	4	49	3	12° 57' 10"	144,223	2GD
90	125	23	23	1,5	18	1,5	12° 51'	111,282	2BC
90	135	28	27,5	2,5	23	2	12° 01' 30"	119,139	2CC
90	140	34	33	2,5	28	2,5	12° 02' 30"	121,860	2CD
90	140	39	39	2	32,5	1,5	10° 10'	122,363	2CE
90	155	46	46	3	38	3	12° 17'	130,206	2ED
90	190	46,5	43	4	36	3	12° 57' 10"	159,061	2GB
90	190	67,5	64	4	53	3	12° 57' 10"	151,701	2GD
95	130	23	23	1,5	18	1,5	13° 25'	116,082	2BC
95	140	28	27,5	2,5	23	2,5	12° 30'	123,797	2CC
95	145	34	33	2,5	28	2,5	12° 30'	126,419	2CD
95	145	39	39	2	32,5	1,5	10° 30'	126,346	2CE
95	160	46	46	3	38	3	12° 43'	134,711	2ED
95	200	49,5	45	4	38	3	12° 57' 10"	165,861	2GB
95	200	71,5	67	4	55	3	12° 57' 10"	160,318	2GD
100	140	25	25	1,5	20	1,5	12° 23'	125,717	2CC
100	145	28	27,5	2,5	23	2,5	12° 58' 30"	128,448	2DC
100	150	34	33	2,5	28	2,5	12° 57' 30"	130,992	2CD
100	150	39	39	2	32,5	1,5	10° 50'	130,323	2CE
100	165	47	46	3	39	3	12°	140,251	2EE
100	215	51,5	47	4	39	3	12° 57' 10"	178,578	2GB
100	215	77,5	73	4	60	3	12° 57' 10"	171,650	2GD
105	145	25	25	1,5	20	1,5	12° 51'	130,359	2CC
105	155	33	31,5	2,5	27	2,5	12° 17' 30"	137,045	2CD
105	160	38	37	3	31	2,5	12° 17' 30"	139,734	2DD
105	160	43	43	2,5	34	2	10° 40'	139,304	2DE
105	170	47	46	3	39	3	12° 18' 30"	145,104	2EE
105	225	53,5	49	4	41	3	12° 57' 10"	186,752	2GB
105	225	81,5	77	4	63	3	12° 57' 10"	179,359	2GD

TABLE 2 (continued)

Values in millimetres and degrees

<i>d</i>	<i>D</i>	<i>T</i>	<i>B</i>	<i>r</i> _{1smin} <i>r</i> _{2smin}	<i>C</i>	<i>r</i> _{3smin} <i>r</i> _{4smin}	<i>α</i>	<i>E</i>	Dimension series
110	150	25	25	1,5	20	1,5	13° 20'	135,182	2CC
110	160	33	31,5	2,5	27	2,5	12° 42' 30"	141,607	2CD
110	165	38	37	3	31	2,5	12° 42' 30"	144,376	2DD
110	170	47	47	2,5	37	2	10° 50'	146,265	2DE
110	175	47	46	4	39	3	12° 41' 30"	149,543	2EE
110	240	54,5	50	4	42	3	12° 57' 10"	199,925	2GB
110	240	84,5	80	4	65	3	12° 57' 10"	192,071	2GD
120	165	29	29	1,5	23	1,5	13° 05'	148,464	2CC
120	175	36	35	2,5	29	2,5	12° 08'	155,479	2DC
120	180	41	40	3	33	2,5	12° 08' 30"	158,233	2DD
120	180	48	48	2,5	38	2	11° 30'	154,777	2DE
120	190	50	49	4	41	3	12° 09' 30"	163,635	2EE
120	260	59,5	55	4	46	3	12° 57' 10"	214,892	2GB
120	260	90,5	86	4	69	3	12° 57' 10"	207,039	2GD
130	180	32	32	2	25	1,5	12° 45'	161,652	2CC
130	185	36	35	3	29	2,5	12° 52'	164,714	2DC
130	190	41	40	3	33	2,5	12° 51' 30"	167,414	2DD
130	200	50	49	4	41	3	12° 50' 30"	172,653	2DE
130	200	55	55	2,5	43	2	12° 50'	172,017	2EE
130	280	63,75	58	5	49	4	12° 57' 10"	232,028	2GB
140	190	32	32	2	25	1,5	13° 30'	171,032	2CC
140	200	39	38	3	31	2,5	12°	179,234	2DC
140	205	44	43	3	36	2,5	12°	181,645	2DD
140	210	56	56	2,5	44	2	13° 30'	180,353	2DE
140	215	53	52	4	44	3	12°	187,051	2ED
140	300	67,75	62	5	53	4	12° 57' 10"	247,910	2GB
150	210	38	38	2,5	30	2	12° 20'	187,926	2DC
150	215	44	43	3	36	3	12° 37'	190,810	2DD
150	225	53	52	4	44	4	12° 35' 30"	196,097	2ED
150	225	59	59	3	46	2,5	13° 40'	194,260	2EE
150	320	72	65	5	55	4	12° 57' 10"	265,955	2GB
160	220	38	38	2,5	30	2	13°	197,962	2DC
160	225	44	43	3	36	3	13° 14' 30"	200,146	2DD
160	235	53	52	4	44	4	13° 11' 30"	205,257	2ED
160	340	75	68	5	58	4	12° 57' 10"	282,751	2GB
170	235	44	43	3	36	3	12° 13' 30"	211,345	2DD
170	245	53	52	5	44	4	12° 14'	216,610	2ED
170	360	80	72	5	62	4	12° 57' 10"	299,991	2GB
180	240	39	38	3	31	3	12° 47'	218,311	2DC
180	245	44	43	3	36	3	12° 46' 30"	220,684	2DD
180	255	53	52	5	44	4	12° 46'	225,875	2ED

TABLE 2 (concluded)

Values in millimetres and degrees

d	D	T	B	$r_{1\text{smin}}$ $r_{2\text{smin}}$	C	$r_{3\text{smin}}$ $r_{4\text{smin}}$	α	E	Dimension series
190	255	41	40	3	33	3	12° 15'	232,395	2DC
190	260	47	46	4	38	3	12° 15'	234,615	2DD
190	270	56	55	5	46	4	12° 15' 30''	240,017	2ED
200	265	41	40	3	33	3	12° 45'	241,710	2DC
200	270	47	46	4	38	3	12° 45'	244,043	2DD
200	280	56	55	5	46	4	12° 44' 30''	249,300	2ED
220	285	41	40	4	33	3	12°	262,657	2DC
220	290	47	46	4	38	3	12°	265,261	2DD
220	300	56	55	5	46	4	12° 04' 30''	270,389	2ED
240	305	41	40	4	33	3	12° 53'	281,653	2DC
240	310	47	46	4	38	3	12° 52'	284,085	2DD
240	320	57	56	6	46	4	12° 55' 30''	289,075	2EE
260	325	41	40	4	33	4	13° 46'	300,661	2DC
260	330	47	46	4	38	4	13° 44' 30''	303,004	2DD
260	340	57	56	6	46	4	12° 07' 30''	310,322	2DE
280	360	57	56	6	46	5	12° 52' 30''	329,164	2DE

iTeh STANDARD PREVIEW
(standards.iteh.ai)

ISO 355:1977

<https://standards.iteh.ai/catalog/standards/sist/e29803b3-e05f-4249-ac17-e15e10c73406/iso-355-1977>