Road vehicles — Fuse-links —

Part 7:

**Fuse-links with tabs (Type G) with rated
voltage of 450 V**

Véhicules routiers — Liaisons fusibles —

*Partie 7: Fusibles avec languettes (de type G) avec une tension
nominale de 450 V*

**iTeh STANDARD PREVIEW
(standards.iteh.ai)**

ISO 8820-7:2007

<https://standards.iteh.ai/catalog/standards/sist/fl efd332-e463-4903-a413-c8593de7ac09/iso-8820-7-2007>



Reference number
ISO 8820-7:2007(E)

PDF disclaimer

This PDF file may contain embedded typefaces. In accordance with Adobe's licensing policy, this file may be printed or viewed but shall not be edited unless the typefaces which are embedded are licensed to and installed on the computer performing the editing. In downloading this file, parties accept therein the responsibility of not infringing Adobe's licensing policy. The ISO Central Secretariat accepts no liability in this area.

Adobe is a trademark of Adobe Systems Incorporated.

Details of the software products used to create this PDF file can be found in the General Info relative to the file; the PDF-creation parameters were optimized for printing. Every care has been taken to ensure that the file is suitable for use by ISO member bodies. In the unlikely event that a problem relating to it is found, please inform the Central Secretariat at the address given below.

iTeh STANDARD PREVIEW
(standards.iteh.ai)

ISO 8820-7:2007

<https://standards.iteh.ai/catalog/standards/sist/fl efd332-e463-4903-a413-c8593de7ac09/iso-8820-7-2007>



COPYRIGHT PROTECTED DOCUMENT

© ISO 2007

All rights reserved. Unless otherwise specified, no part of this publication may be reproduced or utilized in any form or by any means, electronic or mechanical, including photocopying and microfilm, without permission in writing from either ISO at the address below or ISO's member body in the country of the requester.

ISO copyright office
Case postale 56 • CH-1211 Geneva 20
Tel. + 41 22 749 01 11
Fax + 41 22 749 09 47
E-mail copyright@iso.org
Web www.iso.org

Published in Switzerland

Contents

Page

Foreword.....	iv
1 Scope	1
2 Normative references	1
3 Terms and definitions.....	1
4 Marking, labelling and colour coding	2
5 Tests and requirements	2
5.1 General.....	2
5.2 Voltage drop	4
5.3 Transient current cycling.....	5
5.4 Environmental conditions.....	5
5.5 Operating time rating.....	5
5.6 Current steps.....	6
5.7 Breaking capacity	6
5.8 Terminal strength.....	6
6 Dimensions and designation examples	7
6.1 Types.....	7
6.2 Fuse-links with $I_R < 35$ A.....	8
6.3 Fuse-links with $I_R \geq 35$ A.....	9
6.4 Designation example.....	9
7 Test fixture.....	10
7.1 Test fixture for fuse-links with $I_R < 35$ A.....	10
7.2 Test fixture for fuse-links with $I_R \geq 35$ A.....	12
Bibliography	14

Foreword

ISO (the International Organization for Standardization) is a worldwide federation of national standards bodies (ISO member bodies). The work of preparing International Standards is normally carried out through ISO technical committees. Each member body interested in a subject for which a technical committee has been established has the right to be represented on that committee. International organizations, governmental and non-governmental, in liaison with ISO, also take part in the work. ISO collaborates closely with the International Electrotechnical Commission (IEC) on all matters of electrotechnical standardization.

International Standards are drafted in accordance with the rules given in the ISO/IEC Directives, Part 2.

The main task of technical committees is to prepare International Standards. Draft International Standards adopted by the technical committees are circulated to the member bodies for voting. Publication as an International Standard requires approval by at least 75 % of the member bodies casting a vote.

Attention is drawn to the possibility that some of the elements of this document may be the subject of patent rights. ISO shall not be held responsible for identifying any or all such patent rights.

ISO 8820-7 was prepared by Technical Committee ISO/TC 22, *Road vehicles*, Subcommittee SC 3, *Electrical and electronic equipment*.

ISO 8820 consists of the following parts, under the general title *Road vehicles — Fuse-links*:

- iTeh STANDARD PREVIEW**
(standards.iteh.ai)
- *Part 1: Definitions and general test requirements*
 - *Part 2: User's guide* <https://standards.iteh.ai/catalog/standards/sist/fl efd332-e463-4903-a413-c8593de7ac09/iso-8820-7-2007>
 - *Part 3: Fuse-links with tabs (blade type)*
 - *Part 4: Fuse-links with female contacts (type A) and bolt-in contacts (type B) and their test fixtures*
 - *Part 5: Fuse-links with axial terminals (Strip fuse-links) Types SF 30 and SF 51 and test fixtures*
 - *Part 6: Single-bolt fuse-links*
 - *Part 7: Fuse-links with tabs (Type G) with rated voltage of 450 V*

Road vehicles — Fuse-links —

Part 7:

Fuse-links with tabs (Type G) with rated voltage of 450 V

1 Scope

This part of ISO 8820 specifies fuse-links with tabs (Type G) in road vehicles. This type of fuse-link is basically designed for use in fuel-cell applications. This part of ISO 8820 establishes, for this fuse-link type, the rated current, test procedures, performance requirements and dimensions.

This part of ISO 8820 is applicable for fuse-links with a rated voltage of 450 V, a current rating of ≤ 70 A and a breaking capacity of 2 000 A intended for use in road vehicles at a nominal voltage up to 450 V.

This part of ISO 8820 is intended to be used in conjunction with ISO 8820-1:—¹⁾ and ISO 8820-2. The numbering of its clauses corresponds to that of ISO 8820-1:—¹⁾, the requirements of which are applicable except where modified by requirements particular to this part of ISO 8820.

(standards.iteh.ai)

2 Normative references

ISO 8820-7:2007

The following referenced documents are indispensable for the application of this document. For dated references, only the edition cited applies. For undated references, the latest edition of the referenced document (including any amendments) applies.

ISO 6722, *Road vehicles — 60 V and 600 V single-core cables — Dimensions, test methods and requirements*

ISO 8092-1, *Road vehicles — Connections for on-board electrical wiring harnesses — Part 1: Tabs for single-pole connections — Dimensions and specific requirements*

ISO 8820-1:—¹⁾, *Road vehicles — Fuse-links — Part 1: Definitions and general test requirements*

3 Terms and definitions

For the purposes of this document, the terms and definitions given in ISO 8820-1:—¹⁾ apply.

1) To be published. (Revision of ISO 8820-1:2002)

4 Marking, labelling and colour coding

The requirements given in ISO 8820-1:—¹⁾ and in Table 1 of this part of ISO 8820 apply.

Table 1 — Fuse-link colour coding

Fuse-link rating A	Colour
10	red
15	blue
20	yellow
25	white (natural)
30	green
35	dark green
40	orange
50	red
60	blue
70	brown

ITeH STANDARD PREVIEW
(standards.iteh.ai)

5 Tests and requirements

5.1 General

ISO 8820-7:2007

In addition to carrying out the test procedures in accordance with ISO 8820-1:—¹⁾, the following criteria apply.

- Tests shall be performed following the test sequence in Table 2.
- The test fixtures for electrical tests shall be designed in accordance with Figures 3 and 4. The connection resistance shall be $\leq 1,0$ m Ω to ensure the proper function of the test fixture. As two or more fuse-links are tested in series, they shall be mounted not less than 150 mm apart.

5.1.1 Test sequence

Table 2 — Test sequence

No.	Test	Clause	Sample group					
			1	2	3	4	5	6
1	Dimensions	6	X	X	X			
2	Marking, labelling and colour coding	4	X	X	X	X	X	X
3	Fuse-link voltage drop	5.2	X	X	X			
4	Strength of terminals	5.6	X	X	X			
5	Accelerated ageing	5.4			X			
6	Fluid compatibility					X		
7	Vibration						X	
8	Transient current cycling	5.3						X
9	Fuse-link voltage drop	5.2			X	X	X	X
10	Operating time rating	5.5		Y	Y	Y	Y	Y
				Y	Y	Y	Y	Y
				Y	Y	Y	Y	Y
11	Strength of terminals	5.8	X	X	X	X	X	X

^a This current is used to test the breaking capacity (see 5.5 and 5.7).

Y For these operating time tests, the sample groups 2, 3, 4, 5 and 6 shall be divided equally. These fuses are intended to be subjected to a single operating time test only.

<https://standards.iteh.ai/catalog/standards/sist/fl efd332-e463-4903-a413-c8593de7ac09/iso-8820-7-2007>

5.1.2 Test cable sizes

Test cable sizes shall be as given in Table 3. All tests for a particular fuse-link rating shall be performed using the same cable size.

Test cable sizes are specified to allow comparative fuse-link tests to be carried out. The cable size specified does not necessarily indicate the size of cable to be used in the vehicle application.

Only thick-wall cables as specified in ISO 6722 shall be used for testing.

Table 3 — Test cable sizes

Fuse-link rating A	Conductor cross-sectional area ^a mm ²
10	1,0
15	1,5
20	2,5
25	
30	4
35	
40	10
50	
60	10
70	16

^a Conductor material according to ISO 6722.

5.2 Voltage drop

5.2.1 Test

The fuse-link voltage drop U_{ab} shall be measured at points a and b across the fuse-link tabs, as shown in Figure 5, or U_{ab} and U_{cd} shall be measured at points a, b and c, d across the fuse-link tabs, as shown in Figure 7.

<https://standards.iteh.ai/catalog/standards/sist/fl efd332-e463-4903-a413-c8593de7ac09/iso-8820-7-2007>
 (standards.iteh.ai)
 ISO 8820-7:2007

5.2.2 Requirements

Table 4 gives the voltage drop requirements.

Table 4 — Fuse-link voltage drop

Fuse-link rating A	Voltage drop V
1	2,000
5	0,400
10	0,200
15	0,190
20	0,175
25	0,140
35	0,114
50	0,080
70	0,080

5.3 Transient current cycling

5.3.1 Test

See Figure 1 and ISO 8820-1. At an elapsed time of 0,025 s on-time, the current shall fall to a value between $1,65I_R$ and $2,5I_R$. At no time shall the steady-state current fall below $0,9I_R$.

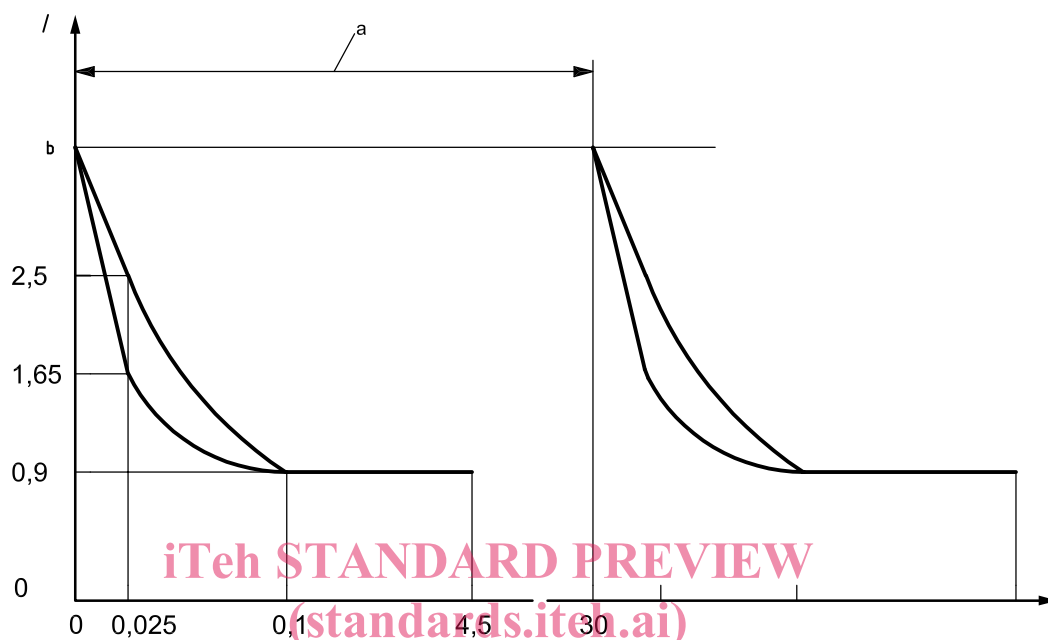

Key

I current [I_R]

t time [s]

a One cycle.

b $(5,6 \dots 6)I_R$ for $I_R > 5$ A; $(4,6 \dots 5)I_R$ for $I_R \leq 5$ A.

ISO 8820-7:2007

<https://standards.iteh.ai/catalog/standards/sist/fl efd332-e463-4903-a413-c8593de7ac09/iso-8820-7-2007>

Figure 1 — Transient current cycling

5.3.2 Requirement

The requirements given in ISO 8820-1 apply.

5.4 Environmental conditions

The tests and requirements given in ISO 8820-1:—¹⁾ apply.

5.5 Operating time rating

5.5.1 Test

The tests given in ISO 8820-1:—¹⁾ apply.

The rated voltage U_R shall be maintained for a period of at least 30 s after the fuse-link is activated.

For breaking capacity, the time constant shall be 7,5 ... 10 ms.

5.5.2 Requirement

The requirements given in ISO 8820-1 apply.

The voltage during operation of the fuse-link shall not exceed 2 000 V.

See Tables 5 and 6. After activation, the current through the fuse-link shall not exceed 5 mA at the rated voltage of the fuse-link.

Table 5 — Operating time rating for fuse-links with $I_R < 35$ A

Test current	Operating time s	
	min.	max.
$2I_R$	20	200
300 A	0	0,1
2 000 A ^a	0	0,01

^a This current is used to test the breaking capacity.

Table 6 — Operating time rating for fuse-links $I_R \geq 35$ A

Test current	Operating time s	
	min.	max.
$2I_R$	60	600
300 A	0	10
2 000 A ^a	0	0,01

^a This current is used to test the breaking capacity.

5.6 Current steps

This test does not apply to this type of fuse-link.

5.7 Breaking capacity

The tests and requirements are given in 5.5.

5.8 Terminal strength

5.8.1 Test

A force (F_1, F_2) shall be applied to the tabs of the fuse-link in accordance with Table 7 and Figure 2.

5.8.2 Requirement

Table 7 — Terminal push and pull forces

Fuse-link rating	Push (F_1) and pull (F_2) forces
A	N
< 35	90 ± 1
≥ 35	90 ± 1 (each tab)

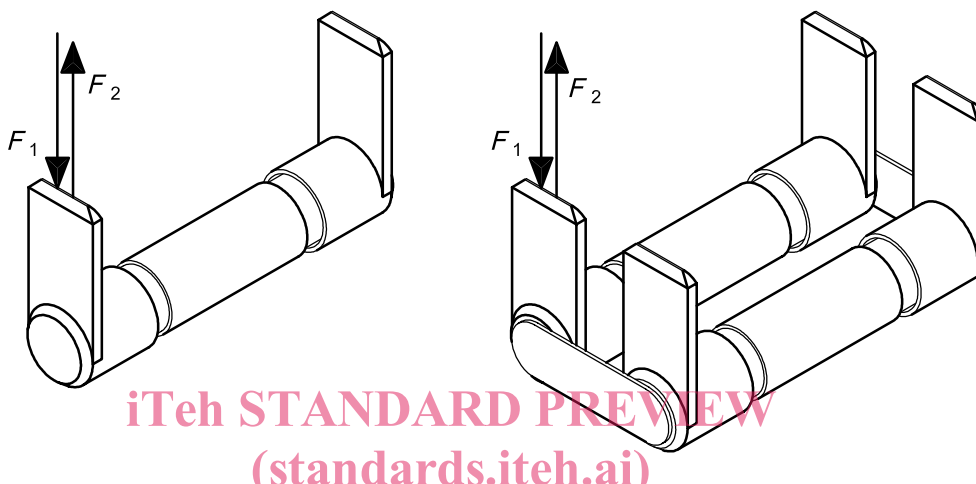

iTeh STANDARD PREVIEW
(standards.iteh.ai)

Key

- F_1 push force
- F_2 pull force

ISO 8820-7:2007
<https://standards.iteh.ai/catalog/standards/sist/fl efd332-e463-4903-a413-c8593de7ac09/iso-8820-7-2007>

Figure 2 — Terminal push and pull forces

6 Dimensions and designation examples

6.1 Types

Table 8 — Types

Fuse-link rating	Type in accordance with Figure ...
A	
< 35	3
≥ 35	4