**Anaesthetic and respiratory equipment —
Conical connectors —**

Part 2:
**Screw-threaded weight-bearing
connectors**

iTeh STANDARD PREVIEW
(standards.iteh.ai)
*Matériel d'anesthésie et de réanimation respiratoire — Raccords
coniques —
Partie 2: Raccords à vis supportant un certain poids*

ISO 5356-2:2006

<https://standards.iteh.ai/catalog/standards/sist/33dbbd0-5db2-4e2f-9978-1e9541ec2a3a/iso-5356-2-2006>



PDF disclaimer

This PDF file may contain embedded typefaces. In accordance with Adobe's licensing policy, this file may be printed or viewed but shall not be edited unless the typefaces which are embedded are licensed to and installed on the computer performing the editing. In downloading this file, parties accept therein the responsibility of not infringing Adobe's licensing policy. The ISO Central Secretariat accepts no liability in this area.

Adobe is a trademark of Adobe Systems Incorporated.

Details of the software products used to create this PDF file can be found in the General Info relative to the file; the PDF-creation parameters were optimized for printing. Every care has been taken to ensure that the file is suitable for use by ISO member bodies. In the unlikely event that a problem relating to it is found, please inform the Central Secretariat at the address given below.

iTeh STANDARD PREVIEW
(standards.iteh.ai)

ISO 5356-2:2006

<https://standards.iteh.ai/catalog/standards/sist/3f3dbbd0-5db2-4e2f-9978-1e9541ec2a3a/iso-5356-2-2006>

© ISO 2006

All rights reserved. Unless otherwise specified, no part of this publication may be reproduced or utilized in any form or by any means, electronic or mechanical, including photocopying and microfilm, without permission in writing from either ISO at the address below or ISO's member body in the country of the requester.

ISO copyright office
Case postale 56 • CH-1211 Geneva 20
Tel. + 41 22 749 01 11
Fax + 41 22 749 09 47
E-mail copyright@iso.org
Web www.iso.org

Published in Switzerland

Foreword

ISO (the International Organization for Standardization) is a worldwide federation of national standards bodies (ISO member bodies). The work of preparing International Standards is normally carried out through ISO technical committees. Each member body interested in a subject for which a technical committee has been established has the right to be represented on that committee. International organizations, governmental and non-governmental, in liaison with ISO, also take part in the work. ISO collaborates closely with the International Electrotechnical Commission (IEC) on all matters of electrotechnical standardization.

International Standards are drafted in accordance with the rules given in the ISO/IEC Directives, Part 2.

The main task of technical committees is to prepare International Standards. Draft International Standards adopted by the technical committees are circulated to the member bodies for voting. Publication as an International Standard requires approval by at least 75 % of the member bodies casting a vote.

Attention is drawn to the possibility that some of the elements of this document may be the subject of patent rights. ISO shall not be held responsible for identifying any or all such patent rights.

ISO 5356-2 was prepared by Technical Committee ISO/TC 121, *Anaesthetic and respiratory equipment*, Subcommittee SC 1, *Breathing attachments and anaesthetic machines*.

This second edition cancels and replaces the first edition (ISO 5356-2:1987) which has been technically revised.

ISO 5356 consists of the following parts, under the general title *Anaesthetic and respiratory equipment — Conical connectors*:

— Part 1: *Cones and sockets*

— Part 2: *Screw-threaded weight-bearing connectors*

iTeh STANDARD PREVIEW
(standards.iteh.ai)

<https://standards.iteh.ai/catalog/standards/sist/33dbbd0-5db2-4e2f-9978-1e9541ec2a3a/iso-5356-2-2006>

Introduction

Whereas the conical connectors specified in ISO 5356-1 are satisfactory for lightweight breathing attachments, there is also a need for more substantial connectors to support heavy or fragile components. Factors governing the design of these connectors include robustness, simplicity, ease of sterilization, and ease of engagement and disengagement by hand. They should also be compatible with connectors meeting the requirements laid down in ISO 5356-1 and should, if possible, eliminate the likelihood of inadvertent misconnection, although it has to remain the responsibility of the user to check that any system in which they are used is correctly assembled before use.

Screw-threaded weight-bearing connectors specified in this part of ISO 5356 may be used for attachments within the breathing system and at the common gas outlet.

iTeh STANDARD PREVIEW (standards.iteh.ai)

ISO 5356-2:2006

<https://standards.iteh.ai/catalog/standards/sist/33dbbd0-5db2-4e2f-9978-1e9541ec2a3a/iso-5356-2-2006>

Anaesthetic and respiratory equipment — Conical connectors —

Part 2: Screw-threaded weight-bearing connectors

1 Scope

This part of ISO 5356 specifies requirements for screw-threaded weight-bearing conical connectors intended for use with inhalation anaesthesia apparatus and ventilators; such connectors are intended for mounting heavy accessories.

2 Normative references

The following referenced documents are indispensable for the application of this document. For dated references, only the edition cited applies. For undated references, the latest edition of the referenced document (including any amendments) applies.

ISO 965-2:1998, *ISO general purpose metric screw threads — Tolerances — Part 2: Limits of sizes for general purpose external and internal screw threads — Medium quality*

ISO 5356-1:2004, *Anaesthetic and respiratory equipment — Conical connectors — Part 1: Cones and sockets*

3 Terms and definitions

For the purposes of this document, the following terms and definitions apply.

3.1

inhalation anaesthesia apparatus

equipment intended for dispensing and delivering anaesthetic gases and vapours into a breathing system for delivery to the patient

NOTE Adapted from ISO 4135:2001, definition 2.1.1.

3.2

breathing attachments

components intended to make up or complete a breathing system

NOTE Adapted from ISO 4135:2001, definition 4.1.6.

3.3 breathing system

those gas pathways continuously or intermittently in communication with the patient's respiratory tract during any form of ventilation

NOTE 1 In practice a breathing system usually extends from

- a) the point of supply¹⁾ of a controlled gas mixture, e.g. the common gas outlet of an anaesthetic machine or
- b) the fresh-gas inlet of a circle system, lung ventilator, T-piece, etc. or
- c) the fresh-gas inlet of a manually-operated resuscitator.

NOTE 2 It usually extends to the point at which the gas mixture escapes into the atmosphere or a gas scavenging system, for example from an APL valve, the open end of a T-piece, etc.

NOTE 3 Gas pathways exclusively concerned with gas scavenging systems are not regarded as part of the breathing system.

NOTE 4 Adapted from ISO 4135:2001, definition 4.1.1.

4 Design

The dimensions of the components of screw-threaded weight-bearing connectors shall be as shown in Figure 1.

The free axial movement of the union nut on the female component shall be not more than 2 mm in order that, when the connectors are unscrewed, the male and female components shall be forced apart.

All male screw threads shall be M33 × 2-6 g and all female screw threads shall be M33 × 2-6 H in accordance with ISO 965-2:1998.

1) In some situations, particularly in lung ventilators, this point may be inside a piece of equipment and should not be confused with a connection port fitted elsewhere, for example on the casing of a ventilator.

Dimensions in millimetres

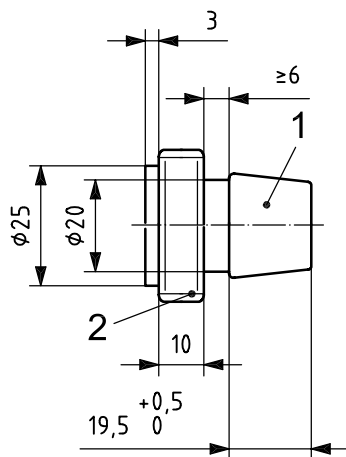

a) Male component

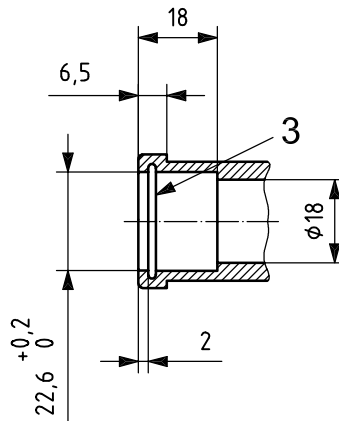

b) Female component — Parallel socket (only essential dimensions shown)^a

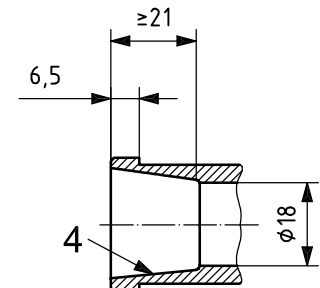

c) Female component — Taper and socket (only essential dimensions shown)^a

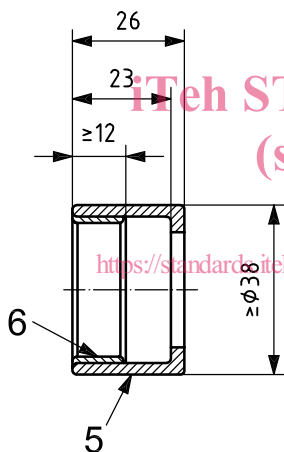

d) Union nut (only essential dimensions shown)

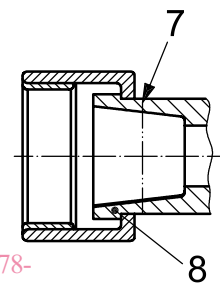

e) Typical female component assembly

Key

- 1 male 22 mm cone or 22 mm/15 mm coaxial as specified in ISO 5356-1:2004
- 2 male screw thread
- 3 O-ring groove [recommended size $\Phi 24,8 \times (2,3 + 0,2/0)$ wide] to suit O-ring of recommended size 22,1 internal diameter and 1,6 cross-section
- 4 22 mm female conical socket as specified in ISO 5356-1:2004
- 5 knurled
- 6 female screw thread
- 7 position of retaining lug, shoulder or circlip
- 8 retaining shoulder^b

^a 18 mm diameter intended for use within breathing systems.

^b The union nut may be retained by a circlip in place of a shoulder.

Figure 1 — Components for screw-threaded, weight-bearing connectors

Bibliography

- [1] ISO 262, *ISO general-purpose metric screw threads — Selected sizes for screws, bolts and nuts*
- [2] ISO 4135:2001, *Anaesthetic and respiratory equipment — Vocabulary*

iTeh STANDARD PREVIEW
(standards.iteh.ai)

ISO 5356-2:2006

<https://standards.iteh.ai/catalog/standards/sist/3f3dbbd0-5db2-4e2f-9978-1e9541ec2a3a/iso-5356-2-2006>

iTeh STANDARD PREVIEW
(standards.iteh.ai)

ISO 5356-2:2006

<https://standards.iteh.ai/catalog/standards/sist/33dbbd0-5db2-4e2f-9978-1e9541ec2a3a/iso-5356-2-2006>