



Designation: D 198 – 05a

Standard Test Methods of Static Tests of Lumber in Structural Sizes¹

This standard is issued under the fixed designation D 198; the number immediately following the designation indicates the year of original adoption or, in the case of revision, the year of last revision. A number in parentheses indicates the year of last reapproval. A superscript epsilon (ϵ) indicates an editorial change since the last revision or reapproval.

INTRODUCTION

Numerous evaluations of structural members of solid sawn lumber have been conducted in accordance with Test Methods D 198 – 27. While the importance of continued use of a satisfactory standard should not be underestimated, the original standard (1927) was designed primarily for sawn material, such as solid wood bridge stringers and joists. With the advent of laminated timbers, wood-plywood composite members, and even reinforced and prestressed timbers, a procedure adaptable to a wider variety of wood structural members is required.

The present standard expands the original standard to permit its application to wood members of all types. It provides methods of evaluation under loadings other than flexure in recognition of the increasing need for improved knowledge of properties under such loadings as tension to reflect the increasing use of dimensions lumber in the lower chords of trusses. The standard establishes practices that will permit correlation of results from different sources through the use of a uniform procedure. Provision is made for varying the procedure to take account of special problems.

1. Scope

- 1.1 These test methods cover the evaluation of lumber in structural size by various testing procedures.
- 1.2 The test methods appear in the following order:

	Sections
Flexure	4-11
Compression (Short Column)	12-19
Compression (Long Member)	20-27
Tension	28-35
Torsion	36-43
Shear Modulus	44-51

- 1.3 Notations and symbols relating to the various testing procedures are given in **Appendix X1**.

1.4 *This standard does not purport to address all of the safety concerns, if any, associated with its use. It is the responsibility of the user of this standard to establish appropriate safety and health practices and determine the applicability of regulatory limitations prior to use.*

2. Referenced Documents

2.1 *ASTM Standards:*²

D 9 Terminology Relating to Wood

D 1165 Nomenclature of Domestic Hardwoods and Softwoods

D 2395 Test Methods for Specific Gravity of Wood and Wood-Based Materials

D 2915 Practice for Evaluating Allowable Properties for Grades of Structural Lumber

D 4442 Test Methods for Direct Moisture Content Measurement of Wood and Wood-Base Materials

E 4 Practices for Force Verification of Testing Machines

E 6 Terminology Relating to Methods of Mechanical Testing

E 83 Practice for Verification and Classification of Extensometer System

3. Terminology

3.1 *Definitions*—See Terminology **E 6**, Terminology **D 9**, and Nomenclature **D 1165**. A few related terms not covered in these standards are as follows:

3.1.1 *composite wood beam*—a laminar construction comprising a combination of wood and other simple or complex materials assembled and intimately fixed in relation to each other so as to use the properties of each to attain specific structural advantage for the whole assembly.

3.1.2 *depth of beam*—that dimension of the beam that is perpendicular to the span and parallel to the direction in which the load is applied (**Fig. 1**).

3.1.3 *shear span*—two times the distance between a reaction and the nearest load point for a symmetrically loaded beam (**Fig. 1**).

¹ These test methods are under the jurisdiction of ASTM Committee D07 on Wood and are the direct responsibility of Subcommittee D07.01 on Fundamental Test Methods and Properties.

Current edition approved Oct. 1, 2005. Published October 2005. Originally approved in 1924. Last previous edition approved in 2005 as D 198 – 05.

² For referenced ASTM standards, visit the ASTM website, www.astm.org, or contact ASTM Customer Service at service@astm.org. For *Annual Book of ASTM Standards* volume information, refer to the standard's Document Summary page on the ASTM website.

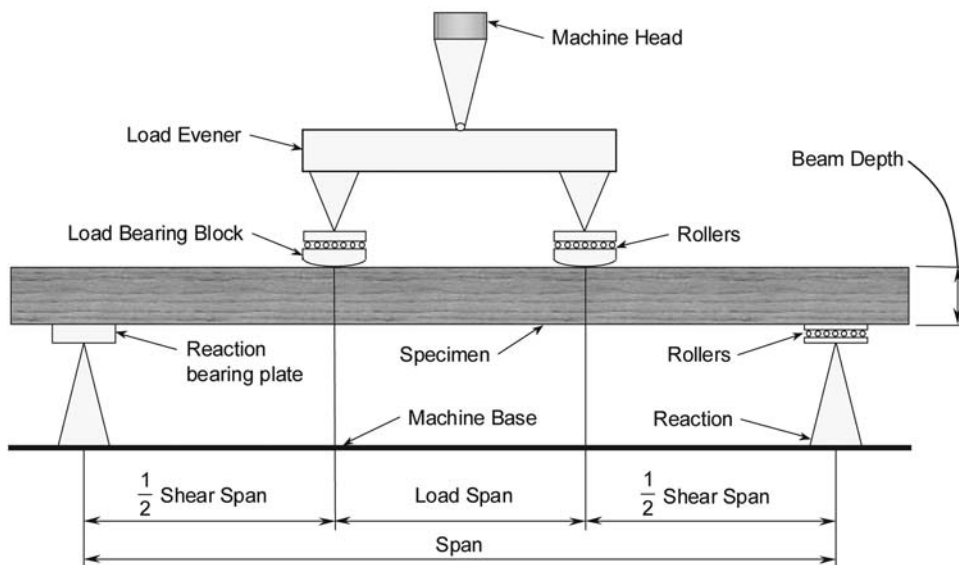

FIG. 1 Flexure Method. Example of Two-Point Loading

3.1.4 *shear span-depth ratio*—the numerical ratio of shear span divided by beam depth.

3.1.5 *span*—the total distance between reactions on which a beam is supported to accommodate a transverse load (Fig. 1).

3.1.6 *span-depth ratio*—the numerical ratio of total span divided by beam depth.

3.1.7 *structural wood beam*—solid wood, laminated wood, or composite structural members for which strength or stiffness, or both are primary criteria for the intended application and which usually are used in full length and in cross-sectional sizes greater than nominal 2 by 2 in. (38 by 38 mm).

6.1.2 Data for use in development of working stresses for structural members,

6.1.3 Data on the influence of imperfections on mechanical properties of structural members,

6.1.4 Data on strength properties of different species or grades in various structural sizes,

6.1.5 Data for use in checking existing equations or hypotheses relating to the structural behavior of beams,

6.1.6 Data on the effects of chemical or environmental conditions on mechanical properties,

6.1.7 Data on effects of fabrication variables such as depth, taper, notches, or type of end joint in laminations, and

6.1.8 Data on relationships between mechanical and physical properties.

FLEXURE

4. Scope

4.1 This test method covers the determination of the flexural properties of structural beams made of solid or laminated wood, or of composite constructions. This test method is intended primarily for beams of rectangular cross section but is also applicable to beams of round and irregular shapes, such as round posts, I-beams, or other special sections.

5. Summary of Test Method

5.1 The structural member, usually a straight or a slightly cambered beam of rectangular cross section, is subjected to a bending moment by supporting it near its ends, at locations called reactions, and applying transverse loads symmetrically imposed between these reactions. The beam is deflected at a prescribed rate, and coordinate observations of loads and deflections are made until rupture occurs.

6. Significance and Use

6.1 The flexural properties established by this test method provide:

6.1.1 Data for use in development of grading rules and specifications,

6.2 Procedures are described here in sufficient detail to permit duplication in different laboratories so that comparisons of results from different sources will be valid. Special circumstances may require deviation from some details of these procedures. Any variations shall be carefully described in the report (see Section 11).

7. Apparatus

7.1 *Testing Machine*—A device that provides (1) a rigid frame to support the specimen yet permit its deflection without restraint, (2) a loading head through which the force is applied without high-stress concentrations in the beam, and (3) a force-measuring device that is calibrated to ensure accuracy in accordance with Practices E 4.

7.2 *Support Apparatus*—Devices that provide support of the specimen at the specified span.

7.2.1 *Reaction Bearing Plates*—The beam shall be supported by metal bearing plates to prevent damage to the beam at the point of contact between beam and reaction support (Fig. 1). The plates shall be of sufficient length, thickness, and width to provide a firm bearing surface and ensure a uniform bearing stress across the width of the beam.

7.2.2 *Reaction Supports*—The bearing plates shall be supported by devices that provide unrestricted longitudinal deformation and rotation of the beam at the reactions due to loading. Provisions shall be made to restrict horizontal translation of the beam (see 7.3.1 and Appendix X5).

7.2.3 *Reaction Bearing Alignment*—Provisions shall be made at the reaction supports to allow for initial twist in the length of the beam. If the bearing surfaces of the beam at its reactions are not parallel, the beam shall be shimmed or the individual bearing plates shall be rotated about an axis parallel to the span to provide full bearing across the width of the specimen. Supports with lateral self-alignment are normally used (Fig. 2).

7.2.4 *Lateral Support*—Specimens that have a depth-to-width ratio of three or greater are subject to lateral instability during loading, thus requiring lateral support. Support shall be provided at least at points located about halfway between a reaction and a load point. Additional supports may be used as required. Each support shall allow vertical movement without frictional restraint but shall restrict lateral displacement (Fig. 3).

7.3 *Load Apparatus*—Devices that transfer load from the testing machine at designated points on the specimen. Provisions shall be made to prevent eccentric loading of the load measuring device (see Appendix X5).

7.3.1 *Load Bearing Blocks*—The load shall be applied through bearing blocks (Fig. 1), which are of sufficient thickness and extending entirely across the beam width to eliminate high-stress concentrations at places of contact between beam and bearing blocks. Load shall be applied to the blocks in such a manner that the blocks may rotate about an axis perpendicular to the span (Fig. 4). To prevent beam deflection without

restraint in case of two-point loading, metal bearing plates and rollers shall be used in conjunction with one or both load-bearing blocks, depending on the reaction support conditions (see Appendix X5). Provisions such as rotatable bearings or shims shall be made to ensure full contact between the beam and the loading blocks. The size and shape of these loading blocks, plates, and rollers may vary with the size and shape of the beam, as well as for the reaction bearing plates and supports. For rectangular beams, the loading surface of the blocks shall have a radius of curvature equal to two to four times the beam depth. Beams having circular or irregular cross-sections shall have bearing blocks that distribute the load uniformly to the bearing surface and permit unrestrained deflections.

7.3.2 *Load Points*—Location of load points relative to the reactions depends on the purpose of testing (see Appendix X5).

7.3.2.1 *Two-Point Loading*—The total load on the beam shall be applied equally at two points equidistant from the reactions. The two load points will normally be at a distance from their reaction equal to one third of the span (third-point loading), but for special purposes other distances may be specified.

7.3.2.2 *Center-Point Loading*—If required, a single load can be applied at mid-span.

7.3.2.3 For evaluation of shear properties, center-point loading or two-point loading shall be used (see Appendix X5).

7.4 *Deflection-Measuring Apparatus:*

7.4.1 *General*—For modulus of elasticity calculations, devices shall be provided by which the deflection of the neutral axis of the beam at the center of the span is measured with respect to a straight line joining two reference points equidistant from the reactions and on the neutral axis of the beam.

7.4.1.1 The apparent modulus of elasticity shall be calculated using the full-span deflection. The reference points for the full-span deflection measurements shall be positioned such that a line perpendicular to the neutral axis at the location of the reference point, passes through the support's center of rotation.

7.4.1.2 The true or shear-free modulus of elasticity shall be calculated using the shear-free deflection. The reference points for the shear-free deflection measurements shall be positioned at cross-sections free of shear and stress concentrations (see Appendix X5).

NOTE 1—The apparent modulus of elasticity may be corrected for shear-corrected MOE calculations, assuming that the shear modulus is known. See Appendix X5.

7.4.2 *Wire Deflectometer*—Deflection may be read directly by means of a wire stretched taut between two nails driven into the neutral axis of the beam directly above the reactions and extending across a scale attached at the neutral axis of the beam at midspan. Deflections may be read with a telescope or reading glass to magnify the area where the wire crosses the scale. When a reading glass is used, a reflective surface placed adjacent to the scale will help to avoid parallax.

7.4.3 *Yoke Deflectometer*—A satisfactory device commonly used for short, small beams or to measure deflection of the center of the beam with respect to any point along the neutral axis consists of a lightweight U-shaped yoke suspended between nails driven into the beam at its neutral axis and a dial

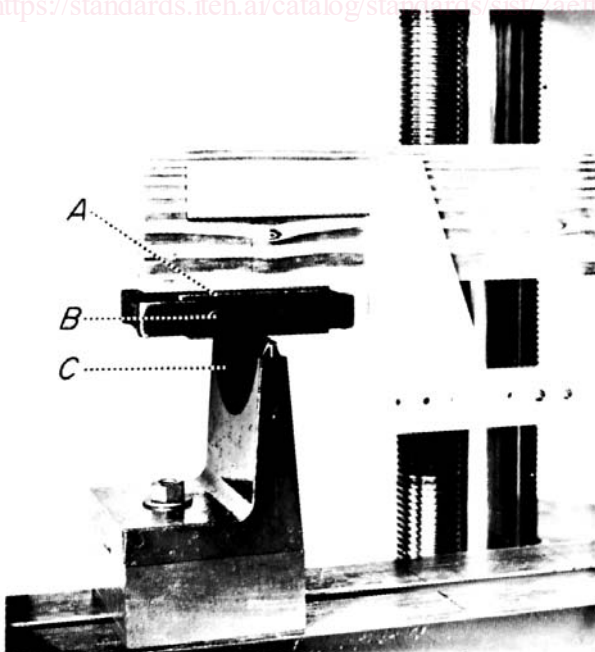

FIG. 2 Example of Bearing Plate (A), Rollers (B), and Reaction-Alignment-Rocker (C), for Small Beams

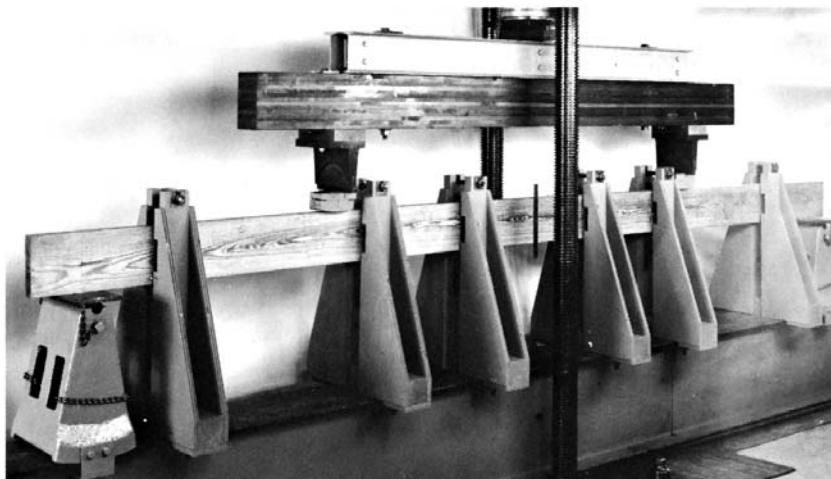

FIG. 3 Example of Lateral Support for Long, Deep Beams

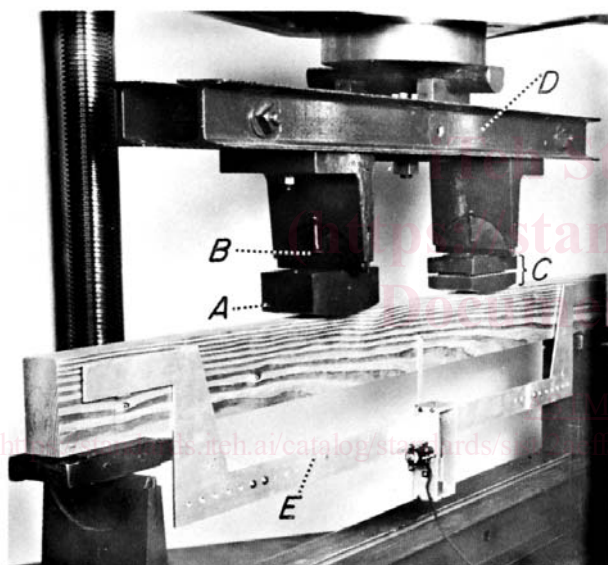

FIG. 4 Example of Curved Loading Block (A), Load-Alignment Rocker (B), Roller-Curved Loading Block (C), Load Evener (D), and Deflection-Measuring Apparatus (E)

micrometer attached to the center of the yoke with its stem attached to a nail driven into the beam at midspan at the neutral axis. Further modification of this device may be attained by replacing the dial micrometer with a deflection transducer for automatic recording (Fig. 4).

7.4.4 *Alternative Deflectometers*—Deflectometers that do not conform to the general requirements of 7.4.1 are permitted provided the mean deflection measurements are not significantly different from those devices conforming to 7.4.1. The equivalency of such devices to deflectometers, such as those described in 7.4.2 or 7.4.3, shall be documented and demonstrated by comparison testing.

NOTE 2—Where possible, equivalency testing should be undertaken in the same type of product and stiffness range for which the device will be

used. Issues that should be considered in the equivalency testing include the effect of crushing at and in the vicinity of the load and reaction points, twist in the specimen, and natural variation in properties within a specimen.

7.4.5 *Accuracy*—The devices and recording system shall be such as to permit measuring changes in deflection to three significant figures. Since gauge lengths vary over a wide range, the measuring instruments should conform to their appropriate class in accordance with Practice E 83.

NOTE 3—A more accurate device may be required if the method selected for computing the slope of the linear portion of the load-deflection response curve does not permit three or more significant figures to be maintained in the calculations.

8. Test Specimen

8.1 *Material*—The test specimen shall consist of a structural member, which may be solid wood, laminated wood, or a composite construction of wood or of wood combined with plastics or metals in sizes that are usually used in structural applications.

8.2 *Identification*—Material or materials of the test specimen shall be identified as fully as possible by including the origin or source of supply, species, and history of drying and conditioning, chemical treatment, fabrication, and other pertinent physical or mechanical details that may affect the strength. Details of this information shall depend on the material or materials in the beam. For example, the solid wooden beams would be identified by the character of the wood, that is, species, source, and so forth, whereas composite wooden beams would be identified by the characteristics of the dissimilar materials and their size and location in the beam.

8.3 *Specimen Measurements*—The weight and dimensions as well as moisture content of the specimen shall be accurately determined before test. Weights and dimensions (length and cross section) shall be measured to three significant figures. Sufficient measurements of the cross section shall be made along the length of the beam to describe the width and depth of rectangular specimen and to accurately describe the critical

section or sections of nonuniform beams. The physical characteristics of the specimen as described by its density and moisture content may be determined in accordance with Test Methods [D 2395](#) and [D 4442](#).

8.4 Specimen Description—The inherent imperfections or intentional modifications of the composition of the beam shall be fully described by recording the size and location of such factors as knots, checks, and reinforcements. Size and location of intentional modifications such as placement of laminations, glued joints, and reinforcing steel shall be recorded during the fabrication process. The size and location of imperfections in the interior of any beam must be deduced from those on the surface, especially in the case of large sawn members. A sketch or photographic record shall be made of each face and the ends showing the size, location, and type of growth characteristics, including slope of grain, knots, distribution of sapwood and heartwood, location of pitch pockets, direction of annual rings, and such abstract factors as crook, bow, cup, or twist, which might affect the strength of the beam.

8.5 Rules for Determination of Specimen Length—The cross-sectional dimensions of solid wood structural beams and composite wooden beams usually have established sizes, depending upon the manufacturing process and intended use, so that no modification of these dimensions is involved. The length, however, will be established by the type of data desired (see [Appendix X5](#)). The span length is determined from knowledge of beam depth, the distance between load points, as well as the type and orientation of material in the beam. The total beam length includes the span (measured from center to center of the reaction supports) and the length of the overhangs (measured from the center of the reaction supports to the ends of the beam). Sufficient length shall be provided so that the beam can accommodate the bearing plates and rollers and will not slip off the reactions during test.

8.5.1 For evaluation of shear properties, the overhang beyond the span shall be minimized, as the shear capacity may be influenced by the length of the overhang. The reaction bearing plates shall be the minimum length necessary to prevent bearing failures. The specimen shall not extend beyond the end of the reaction plates ([Fig. X5.3](#) in [Appendix X5](#)) unless longer overhangs are required to simulate a specific design condition.

9. Procedure

9.1 Conditioning—Unless otherwise indicated in the research program or material specification, condition the test specimen to constant weight so it is in moisture equilibrium under the desired environmental conditions. Approximate moisture contents with moisture meters or measure more accurately by weights of samples in accordance with Test Methods [D 4442](#).

9.2 Test Setup—Determine the size of the specimen, the span, and the shear span in accordance with [7.3.2](#) and [8.5](#). Locate the beam symmetrically on its supports with load bearing and reaction bearing blocks as described in [7.2-7.4](#). The beams shall be adequately supported laterally in accordance with [7.2.4](#). Set apparatus for measuring deflections in place (see [7.4](#)). Full contact shall be attained between support bearings, loading blocks, and the beam surface.

9.3 Speed of Testing—Conduct the test at a constant rate to achieve maximum load in about 10 min, but maximum load should be reached in not less than 6 min nor more than 20 min. A constant rate of outer strain, $\dot{\epsilon}$, of 0.0010 in./in.·min (0.001 mm/mm·min) will usually permit the tests of wood members to be completed in the prescribed time. The rate of motion of the movable head of the test machine corresponding to this suggested rate of strain when two symmetrical concentrated loads are employed may be computed from the following equation:

$$N = \dot{\epsilon} a(3L - 4a) / 3h$$

9.4 Load-Deflection Curves:

9.4.1 Obtain load-deflection data with apparatus described in [7.4.1](#). Note the load and deflection at first failure, at the maximum load, and at points of sudden change. Continue loading until complete failure or an arbitrary terminal load has been reached.

9.4.2 If additional deflection apparatus is provided to measure deflection over a second distance, L_b , in accordance with [7.4.1](#), such load-deflection data shall be obtained only up to the proportional limit.

9.5 Record of Failures—Describe failures in detail as to type, manner, and order of occurrence, and position in beam. Record descriptions of the failures and relate them to drawings or photographs of the beam referred to in [8.4](#). Also record notations as the order of their occurrence on such references. Hold the section of the beam containing the failure for examination and reference until analysis of the data has been completed.

10. Calculation

10.1 Compute physical and mechanical properties and their appropriate adjustments for the beam in accordance with the relationships in [Appendix X2](#).

11. Report

11.1 Report the following information:

11.1.1 Complete identification of the solid wood or composite construction, including species, origin, shape and form, fabrication procedure, type and location of imperfections or reinforcements, and pertinent physical or chemical characteristics relating to the quality of the material,

11.1.2 History of seasoning and conditioning,

11.1.3 Loading conditions to portray the load and support mechanics, including type of equipment, lateral supports, if used, the location of load points relative to the reactions, the size of load bearing blocks, reaction bearing plates, clear distances between load block and reaction plate and between load blocks, and the size of overhangs, if present,

11.1.4 Deflection apparatus,

11.1.5 Depth and width of the specimen or pertinent cross-sectional dimensions,

11.1.6 Span length and shear span distance,

11.1.7 Rate of load application,

11.1.8 Computed physical and mechanical properties, including specific gravity and moisture content, flexural strength,

stress at proportional limit, modulus of elasticity, calculation methods (Note 4), and a statistical measure of variability of these values,

NOTE 4—Appendix X2 provides acceptable formulae and guidance for determining the flexural properties.

11.1.9 Data for composite beams include shear and bending moment values and deflections,

11.1.10 Description of failure, and

11.1.11 Details of any deviations from the prescribed or recommended methods as outlined in the standard.

COMPRESSION PARALLEL TO GRAIN (SHORT COLUMN, NO LATERAL SUPPORT, $L/r < 17$)

12. Scope

12.1 This test method covers the determination of the compressive properties of elements taken from structural members made of solid or laminated wood, or of composite constructions when such an element has a slenderness ratio (length to least radius of gyration) of less than 17. The method is intended primarily for members of rectangular cross section, but is also applicable to irregularly shaped studs, braces, chords, round posts, or special sections.

13. Summary of Test Method

13.1 The structural member is subjected to a force uniformly distributed on the contact surface of the specimen in a direction generally parallel to the longitudinal axis of the wood fibers, and the force generally is uniformly distributed throughout the specimen during loading to failure without flexure along its length.

14. Significance and Use

14.1 The compressive properties obtained by axial compression will provide information similar to that stipulated for flexural properties in Section 6.

14.2 The compressive properties parallel to grain include modulus of elasticity, stress at proportional limit, compressive strength, and strain data beyond proportional limit.

15. Apparatus

15.1 *Testing Machine*—Any device having the following is suitable:

15.1.1 *Drive Mechanism*—A drive mechanism for imparting to a movable loading head a uniform, controlled velocity with respect to the stationary base.

15.1.2 *Load Indicator*—A load-indicating mechanism capable of showing the total compressive force on the specimen. This force-measuring system shall be calibrated to ensure accuracy in accordance with Practices E 4.

15.2 *Bearing Blocks*—Bearing blocks shall be used to apply the load uniformly over the two contact surfaces and to prevent eccentric loading on the specimen. At least one spherical bearing block shall be used to ensure uniform bearing. Spherical bearing blocks may be used on either or both ends of the specimen, depending on the degree of parallelism of bearing surfaces (Fig. 5). The radius of the sphere shall be as small as practicable, in order to facilitate adjustment of the bearing plate

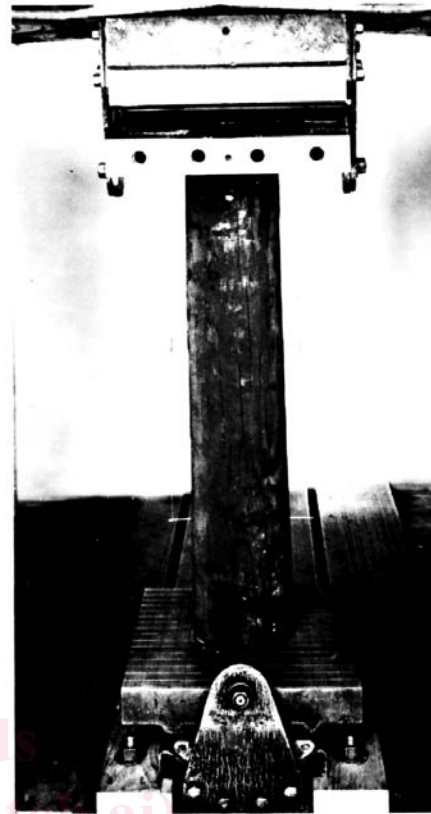

FIG. 5 Compression of a Wood Structural Element

to the specimen, and yet large enough to provide adequate spherical bearing area. This radius is usually one to two times the greatest cross-section dimension. The center of the sphere shall be on the plane of the specimen contact surface. The size of the compression plate shall be larger than the contact surface. It has been found convenient to provide an adjustment for moving the specimen on its bearing plate with respect to the center of spherical rotation to ensure axial loading.

15.3 *Compressometer*:

15.3.1 *Gage Length*—For modulus of elasticity calculations, a device shall be provided by which the deformation of the specimen is measured with respect to specific paired gage points defining the gage length. To obtain test data representative of the test material as a whole, such paired gage points shall be located symmetrically on the lengthwise surface of the specimen as far apart as feasible, yet at least one times the larger cross-sectional dimension from each of the contact surfaces. At least two pairs of such gage points on diametrically opposite sides of the specimen shall be used to measure the average deformation.

15.3.2 *Accuracy*—The device shall be able to measure changes in deformation to three significant figures. Since gage lengths vary over a wide range, the measuring instruments should conform to their appropriate class in accordance with Practice E 83.

16. Test Specimen

16.1 *Material*—The test specimen shall consist of a structural member, which may be solid wood, laminated wood, or a composite construction of wood or of wood combined with plastics or metals in sizes that are commercially used in structural applications, that is, in sizes greater than nominal 2 by 2-in. (38 by 38-mm) cross section (see 3.1.7).

16.2 *Identification*—Material or materials of the test specimen shall be as fully described as that for beams in 8.2.

16.3 *Specimen Dimensions*—The weight and dimensions, as well as moisture content of the specimen, shall be accurately measured before test. Weights and dimensions (length and cross section) shall be measured to three significant figures. Sufficient measurements of the cross section shall be made along the length of the specimen to describe shape characteristics and to determine the smallest section. The physical characteristics of the specimen, as described by its density and moisture content, may be determined in accordance with Test Methods D 2395 and D 4442, respectively.

16.4 *Specimen Description*—The inherent imperfections and intentional modifications shall be described as for beams in 8.4.

16.5 *Specimen Length*—The length of the specimen shall be such that the compressive force continues to be uniformly distributed throughout the specimen during loading—hence no flexure occurs. To meet this requirement, the specimen shall be a short column having a maximum length, l , less than 17 times the least radius of gyration, r , of the cross section of the specimen (see compressive notations). The minimum length of the specimen for stress and strain measurements shall be greater than three times the larger cross section dimension or about ten times the radius of gyration.

17. Procedure

17.1 *Conditioning*—Unless otherwise indicated in the research program or material specification, condition the test specimen to constant weight so it is at moisture equilibrium, under the desired environment. Approximate moisture contents with moisture meters or measure more accurately by weights of samples in accordance with Test Methods D 4442.

17.2 Test Setup:

17.2.1 *Bearing Surfaces*—After the specimen length has been calculated in accordance with 17.5, cut the specimen to the proper length so that the contact surfaces are plane, parallel to each other, and normal to the long axis of the specimen. Furthermore, the axis of the specimen shall be generally parallel to the fibers of the wood.

NOTE 5—A sharp fine-toothed saw of either the crosscut or “novelty” crosscut type has been used satisfactorily for obtaining the proper end surfaces. Power equipment with accurate table guides is especially recommended for this work.

NOTE 6—It is desirable to have failures occur in the body of the specimen and not adjacent to the contact surface. Therefore, the cross-sectional areas adjacent to the loaded surface may be reinforced.

17.2.2 *Centering*—First geometrically center the specimens on the bearing plates and then adjust the spherical seats so that the specimen is loaded uniformly and axially.

17.3 *Speed of Testing*—For measuring load-deformation data, apply the load at a constant rate of head motion so that the fiber strain is 0.001 in./in.·min \pm 25 % (0.001 mm/mm·min). For measuring only compressive strength, the test may be conducted at a constant rate to achieve maximum load in about 10 min, but not less than 5 nor more than 20 min.

17.4 *Load-Deformation Curves*—If load-deformation data have been obtained, note the load and deflection at first failure, at changes in slope of curve, and at maximum load.

17.5 *Records*—Record the maximum load, as well as a description and sketch of the failure relating the latter to the location of imperfections in the specimen. Reexamine the section of the specimen containing the failure during analysis of the data.

18. Calculation

18.1 Compute physical and mechanical properties in accordance with Terminology E 6, and as follows (see compressive notations):

18.1.1 Stress at proportional limit = P'/A in psi (MPa).

18.1.2 Compressive strength = P/A in psi (MPa).

18.1.3 Modulus of elasticity = $P'/A\epsilon$ in psi (MPa).

19. Report

19.1 Report the following information:

19.1.1 Complete identification,

19.1.2 History of seasoning and conditioning,

19.1.3 Load apparatus,

19.1.4 Deflection apparatus,

19.1.5 Length and cross-section dimensions,

19.1.6 Gage length,

19.1.7 Rate of load application,

19.1.8 Computed physical and mechanical properties, including specific gravity and moisture content, compressive strength, stress at proportional limit, modulus of elasticity, and a statistical measure of variability of these values,

19.1.9 Description of failure, and

19.1.10 Details of any deviations from the prescribed or recommended methods as outlined in the standard.

COMPRESSION PARALLEL TO GRAIN (CRUSHING STRENGTH OF Laterally SUPPORTED LONG MEMBER, EFFECTIVE $L'/r < 17$)

20. Scope

20.1 This test method covers the determination of the compressive properties of structural members made of solid or laminated wood, or of composite constructions when such a member has a slenderness ratio (length to least radius of gyration) of more than 17, and when such a member is to be evaluated in full size but with lateral supports that are spaced to produce an effective slenderness ratio, L'/r , of less than 17. This test method is intended primarily for members of rectangular cross section but is also applicable to irregularly shaped studs, braces, chords, round posts, or special sections.

21. Summary of Test Method

21.1 The structural member is subjected to a force uniformly distributed on the contact surface of the specimen in a

direction generally parallel to the longitudinal axis of the wood fibers, and the force generally is uniformly distributed throughout the specimen during loading to failure without flexure along its length.

22. Significance and Use

22.1 The compressive properties obtained by axial compression will provide information similar to that stipulated for flexural properties in Section 6.

22.2 The compressive properties parallel to grain include modulus of elasticity, stress at proportional limit, compressive strength, and strain data beyond proportional limit.

23. Apparatus

23.1 *Testing Machine*—Any device having the following is suitable:

23.1.1 *Drive Mechanism*—A drive mechanism for imparting to a movable loading head a uniform, controlled velocity with respect to the stationary base.

23.1.2 *Load Indicator*—A load-indicating mechanism capable of showing the total compressive force on the specimen. This force-measuring system shall be calibrated to ensure accuracy in accordance with Practices E 4.

23.2 *Bearing Blocks*—Bearing blocks shall be used to apply the load uniformly over the two contact surfaces and to prevent eccentric loading on the specimen. One spherical bearing block shall be used to ensure uniform bearing, or a rocker-type bearing block shall be used on each end of the specimen with their axes of rotation at 0° to each other (Fig. 6). The radius of the sphere shall be as small as practicable, in order to facilitate adjustment of the bearing plate to the specimen, and yet large enough to provide adequate spherical bearing area. This radius is usually one to two times the greatest cross-section dimension. The center of the sphere shall be on the plane of the specimen contact surface. The size of the compression plate shall be larger than the contact surface.

23.3 Lateral Support:

23.3.1 *General*—Evaluation of the crushing strength of long structural members requires that they be supported laterally to prevent buckling during the test without undue pressure against the sides of the specimen. Furthermore, the support shall not restrain either the longitudinal compressive

deformation or load during test. The support shall be either continuous or intermittent. Intermittent supports shall be spaced so that the distance, l' , between supports is less than 17 times the least radius of gyration of the cross section.

23.3.2 *Rectangular Members*—The general rules for structural members apply to rectangular structural members. However, the effective column length as controlled by intermittent support spacing on flatwise face need not equal that on edgewise face. The minimum spacing of the supports on the flatwise face shall be 17 times the least radius of gyration of the cross section, which is about the centroidal axis parallel to flat face. And the minimum spacing of the supports on the edgewise face shall be 17 times the other radius of gyration (Fig. 6). A satisfactory method of providing lateral support for 2-in. (38-mm) dimension stock is shown in Fig. 7. A 27-in. (686-mm) I-beam provides the frame for the test machine. Small I-beams provide reactions for longitudinal pressure. A pivoted top I-beam provides lateral support on one flatwise face, while the web of the large I-beam provides the other. In between these steel members, metal guides on 3-in. (7.6-cm) spacing (hidden from view) attached to plywood fillers provide the flatwise support and contact surface. In between the flanges of the 27-in. I-beam, fingers and wedges provide edgewise lateral support.

23.4 Compressometer:

23.4.1 *Gage Length*—For modulus of elasticity calculations, a device shall be provided by which the deformation of the specimen is measured with respect to specific paired gage points defining the gage length. To obtain data representative of the test material as a whole, such paired gage points shall be located symmetrically on the lengthwise surface of the specimen as far apart as feasible, yet at least one times the larger cross-sectional dimension from each of the contact surfaces. At least two pairs of such gage points on diametrically opposite sides of the specimen shall be used to measure the average deformation.

23.4.2 *Accuracy*—The device shall be able to measure changes in deformation to three significant figures. Since gage lengths vary over a wide range, the measuring instruments should conform to their appropriate class in accordance with Practice E 83.

24. Test Specimen

24.1 *Material*—The test specimen shall consist of a structural member, which may be solid wood, laminated wood, or it may be a composite construction of wood or of wood combined with plastics or metals in sizes that are commercially used in structural applications, that is, in sizes greater than nominal 2 by 2-in. (38 by 38-mm) cross section (see 3.1.7).

24.2 *Identification*—Material or materials of the test specimen shall be as fully described as that for beams in 8.2.

24.3 *Specimen Dimensions*—The weight and dimensions, as well as moisture content of the specimen, shall be accurately measured before test. Weights and dimensions (length and cross section) shall be measured to three significant figures. Sufficient measurements of the cross section shall be made along the length of the specimen to describe shape characteristics and to determine the smallest section. The physical characteristics of the specimen, as described by its density and

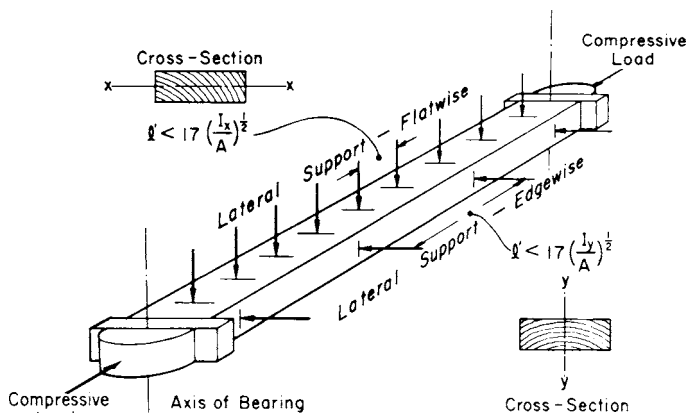

FIG. 6 Minimum Spacing of Lateral Supports of Long Columns

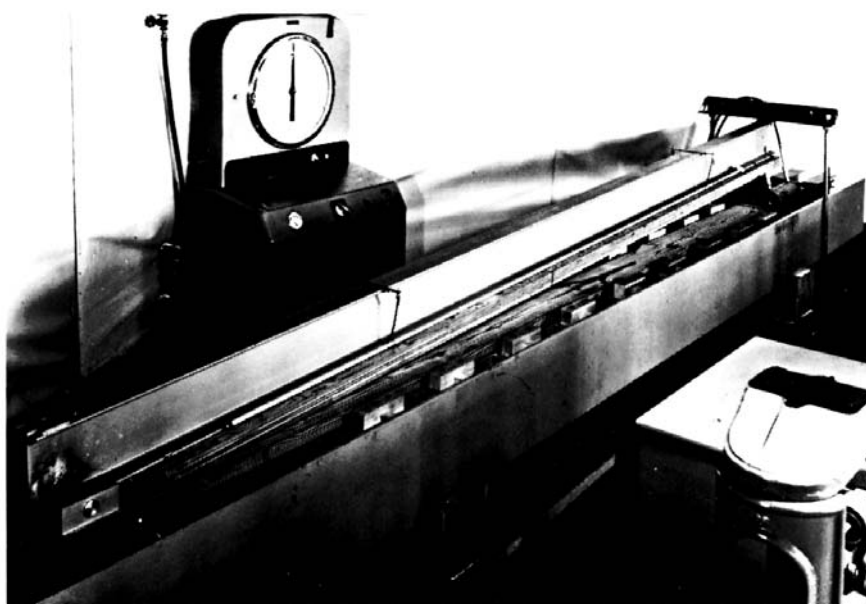

FIG. 7 Compression of Long Slender Structural Member

moisture content, may be determined in accordance with Test Methods **D 2395** and **D 4442**, respectively.

24.4 Specimen Description—The inherent imperfections and intentional modifications shall be described as for beams in **8.4**.

24.5 Specimen Length—The cross-sectional and length dimensions of structural members usually have established sizes, depending on the manufacturing process and intended use, so that no modification of these dimensions is involved. Since the length has been approximately established, the full length of the member shall be tested, except for trimming or squaring the bearing surface (see **25.2.1**).

25. Procedure

25.1 Preliminary—Unless otherwise indicated in the research program or material specification, condition the test specimen to constant weight so it is at moisture equilibrium, under the desired environment. Moisture contents may be approximated with moisture meters or more accurately measured by weights of samples in accordance with Test Methods **D 4442**.

25.2 Test Setup:

25.2.1 Bearing Surfaces—Cut the bearing surfaces of the specimen so that the contact surfaces are plane, parallel to each other, and normal to the long axis of the specimen.

25.2.2 Setup Method—After physical measurements have been taken and recorded, place the specimen in the testing machine between the bearing blocks at each end and between the lateral supports on the four sides. Center the contact surfaces geometrically on the bearing plates and then adjust the spherical seats for full contact. Apply a slight longitudinal pressure to hold the specimen while the lateral supports are adjusted and fastened to conform to the warp, twist, or bend of the specimen.

25.3 Speed of Testing—For measuring load-deformation data, apply the load at a constant rate of head motion so that the

fiber strain is $0.001 \text{ in./in.} \cdot \text{min} \pm 25 \% (0.001 \text{ mm/mm} \cdot \text{min})$. For measuring only compressive strength, the test may be conducted at a constant rate to achieve maximum load in about 10 min, but not less than 5 nor more than 20 min.

25.4 Load-Deformation Curves—If load-deformation data have been obtained, note load and deflection at first failure, at changes in slope of curve, and at maximum load.

25.5 Records—Record the maximum load as well as a description and sketch of the failure relating the latter to the location of imperfections in the specimen. Reexamine the section of the specimen containing the failure during analysis of the data.

26. Calculation

26.1 Compute physical and mechanical properties in accordance with Terminology **E 6** and as follows (see **Appendix X1**):

26.1.1 Stress at proportional limit = P/A in psi (MPa).

26.1.2 Compressive strength = P/A in psi (MPa).

26.1.3 Modulus of elasticity = $P'/A\epsilon$ in psi (MPa).

27. Report

27.1 Report the following information:

27.1.1 Complete identification,

27.1.2 History of seasoning conditioning,

27.1.3 Load apparatus,

27.1.4 Deflection apparatus,

27.1.5 Length and cross-section dimensions,

27.1.6 Gage length,

27.1.7 Rate of load application,

27.1.8 Computed physical and mechanical properties, including specific gravity of moisture content, compressive strength, stress at proportional limit, modulus of elasticity, and a statistical measure of variability of these values,

27.1.9 Description of failure, and

27.1.10 Details of any deviations from the prescribed or recommended methods as outlined in the standard.

TENSION PARALLEL TO GRAIN

28. Scope

28.1 This test method covers the determination of the tensile properties of structural elements made primarily of lumber equal to and greater than nominal 1 in. (19 mm) thick.

29. Summary of Test Method

29.1 The structural member is clamped at the extremities of its length and subjected to a tensile load so that in sections between clamps the tensile forces shall be axial and generally uniformly distributed throughout the cross sections without flexure along its length.

30. Significance and Use

30.1 The tensile properties obtained by axial tension will provide information similar to that stipulated for flexural properties in Section 6.

30.2 The tensile properties obtained include modulus of elasticity, stress at proportional limit, tensile strength, and strain data beyond proportional limit.

31. Apparatus

31.1 *Testing Machine*—Any device having the following is suitable:

31.1.1 *Drive Mechanism*—A drive mechanism for imparting to a movable clamp a uniform, controlled velocity with respect to a stationary clamp.

31.1.2 *Load Indicator*—A load-indicating mechanism capable of showing the total tensile force on the test section of the tension specimen. This force-measuring system shall be calibrated to ensure accuracy in accordance with Practices E 4.

31.1.3 *Grips*—Suitable grips or fastening devices shall be provided that transmit the tensile load from the movable head of the drive mechanism to one end of the test section of the tension specimen, and similar devices shall be provided to transmit the load from the stationary mechanism to the other end of the test section of the specimen. Such devices shall not apply a bending moment to the test section, allow slippage under load, inflict damage, or inflict stress concentrations to the test section. Such devices may be either plates bonded to the specimen or unbonded plates clamped to the specimen by various pressure modes.

31.1.3.1 *Grip Alignment*—The fastening device shall apply the tensile loads to the test section of the specimen without applying a bending moment. For ideal test conditions, the grips should be self-aligning, that is, they should be attached to the force mechanism of the machine in such a manner that they will move freely into axial alignment as soon as the load is applied, and thus apply uniformly distributed forces along the test section and across the test cross section (Fig. 8(a)). For less ideal test conditions, each grip should be gimbaled about one axis, which should be perpendicular to the wider surface of the rectangular cross section of the test specimen, and the axis of rotation should be through the fastened area (Fig. 8(b)). When neither self-aligning grips nor single gimbaled grips are available, the specimen may be clamped in the heads of a universal-type testing machine with wedge-type jaws (Fig. 8(c)). A method of providing approximately full spherical alignment

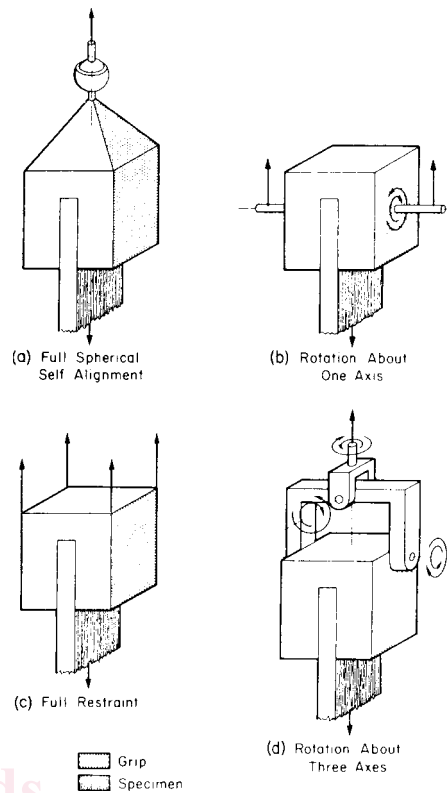

FIG. 8 Types of Tension Grips for Structural Members

has three axes of rotation, not necessarily concurrent but, however, having a common axis longitudinal and through the centroid of the specimen (Fig. 8(d) and Fig. 9).

31.1.3.2 *Contact Surface*—The contact surface between grips and test specimen shall be such that slippage does not occur. A smooth texture on the grip surface should be avoided, as well as very rough and large projections that damage the contact surface of the wood. Grips that are surfaced with a coarse emery paper (60× aluminum oxide emery belt) have been found satisfactory for softwoods. However, for hardwoods, grips may have to be glued to the specimen to prevent slippage.

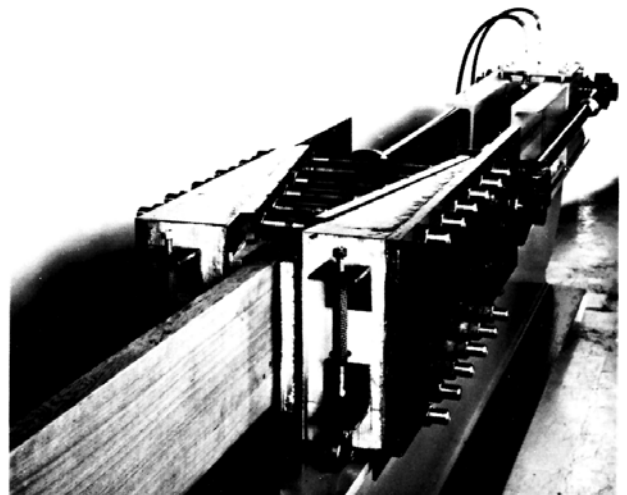

FIG. 9 Horizontal Tensile Grips for 2 by 10-in. Structural Members