

INTERNATIONAL  
STANDARD

ISO  
11644

IULTCS/IUF  
470

Second edition  
2009-05-15

---

---

## Leather — Test for adhesion of finish

*Cuir — Essai d'adhérence du finissage*

iTeh STANDARD PREVIEW  
(standards.iteh.ai)

[ISO 11644:2009](https://standards.iteh.ai/catalog/standards/sist/5ea84e58-3bb1-4905-b856-a1a7aaed70c/iso-11644-2009)

<https://standards.iteh.ai/catalog/standards/sist/5ea84e58-3bb1-4905-b856-a1a7aaed70c/iso-11644-2009>



Reference number  
ISO 11644:2009(E)  
IULTCS/IUF 470:2009(E)

© ISO 2009

**PDF disclaimer**

This PDF file may contain embedded typefaces. In accordance with Adobe's licensing policy, this file may be printed or viewed but shall not be edited unless the typefaces which are embedded are licensed to and installed on the computer performing the editing. In downloading this file, parties accept therein the responsibility of not infringing Adobe's licensing policy. The ISO Central Secretariat accepts no liability in this area.

Adobe is a trademark of Adobe Systems Incorporated.

Details of the software products used to create this PDF file can be found in the General Info relative to the file; the PDF-creation parameters were optimized for printing. Every care has been taken to ensure that the file is suitable for use by ISO member bodies. In the unlikely event that a problem relating to it is found, please inform the Central Secretariat at the address given below.

**iTeh STANDARD PREVIEW**  
**(standards.iteh.ai)**

[ISO 11644:2009](https://standards.iteh.ai/catalog/standards/sist/5ea84e58-3bb1-4905-b856-a1a7aaed70c/iso-11644-2009)

<https://standards.iteh.ai/catalog/standards/sist/5ea84e58-3bb1-4905-b856-a1a7aaed70c/iso-11644-2009>



**COPYRIGHT PROTECTED DOCUMENT**

© ISO 2009

All rights reserved. Unless otherwise specified, no part of this publication may be reproduced or utilized in any form or by any means, electronic or mechanical, including photocopying and microfilm, without permission in writing from either ISO at the address below or ISO's member body in the country of the requester.

ISO copyright office  
Case postale 56 • CH-1211 Geneva 20  
Tel. + 41 22 749 01 11  
Fax + 41 22 749 09 47  
E-mail [copyright@iso.org](mailto:copyright@iso.org)  
Web [www.iso.org](http://www.iso.org)

Published in Switzerland

## Contents

Page

Foreword.....	iv
Introduction .....	v
1 Scope .....	1
2 Normative references .....	1
3 Terms and definitions.....	1
4 Principle .....	1
5 Apparatus and materials .....	2
6 Preparation of test specimens .....	4
7 Conditioning of the test specimens .....	5
8 Procedure .....	6
9 Test report .....	9
Annex A (informative) Commercial sources for apparatus and materials .....	10
Annex B (informative) Precision data from interlaboratory collaborative trial .....	11

(standards.iteh.ai)

[ISO 11644:2009](https://standards.iteh.ai/catalog/standards/sist/5ea84e58-3bb1-4905-b856-a1a7aaed70c/iso-11644-2009)

<https://standards.iteh.ai/catalog/standards/sist/5ea84e58-3bb1-4905-b856-a1a7aaed70c/iso-11644-2009>

## Foreword

ISO (the International Organization for Standardization) is a worldwide federation of national standards bodies (ISO member bodies). The work of preparing International Standards is normally carried out through ISO technical committees. Each member body interested in a subject for which a technical committee has been established has the right to be represented on that committee. International organizations, governmental and non-governmental, in liaison with ISO, also take part in the work. ISO collaborates closely with the International Electrotechnical Commission (IEC) on all matters of electrotechnical standardization.

International Standards are drafted in accordance with the rules given in the ISO/IEC Directives, Part 2.

The main task of technical committees is to prepare International Standards. Draft International Standards adopted by the technical committees are circulated to the member bodies for voting. Publication as an International Standard requires approval by at least 75 % of the member bodies casting a vote.

Attention is drawn to the possibility that some of the elements of this document may be the subject of patent rights. ISO shall not be held responsible for identifying any or all such patent rights.

ISO 11644/IUF 470 was prepared by the European Committee for Standardization (CEN) Technical Committee CEN/TC 289, *Leather*, in collaboration with the Fastness Tests Commission of the International Union of Leather Technologists and Chemists Societies (IUF Commission, IULTCS), in accordance with the Agreement on technical cooperation between ISO and CEN (Vienna Agreement). It is based on IUF 470 published in *J. Soc. Leather Tech. Chem.*, 74, pp. 155-160, 1990, and was declared an official method of the IULTCS in September 1991.

IULTCS, originally formed in 1897, is a world-wide organization of professional leather societies to further the advancement of leather science and technology. IULTCS has three Commissions, which are responsible for establishing international methods for the sampling and testing of leather. ISO recognizes IULTCS as an international standardizing body for the preparation of test methods for leather.

This second edition cancels and replaces the first edition (ISO 11644:1993), which has been technically revised. This new version is a general update of the procedures, including an alternative adhesive and electronic evaluation of the force.

## Introduction

Prior to the first edition of this International Standard in 1993, a similar test method to that specified here, using an epoxy adhesive and metal adherent-plates had been in use in the leather trade for many years, but was never declared an official method by IULTCS or ISO. The adhesive frequently penetrates thin finish films, thus increasing the adhesion value unrealistically, and it is usually not possible to measure wet adhesion, as there is insufficient adhesion to the metal when water is present. Finishes with insufficient adhesion to the adhesive also occur quite frequently. In spite of these drawbacks, this old method was used regularly and was referred to in many specifications. The method specified in this International Standard eliminates most of these drawbacks.

The adhesives used in this method harden quickly and there is no time for them to penetrate even quite thin finishes unless the finish has open cracks in it. While adhesion to most finishes is sufficient, a few cases still exist in which the adhesion is insufficient and either a different adhesive has to be used or the surface lightly roughened. As the adhesive does not penetrate, it is quite possible to test different layers of a multi-layer finish separately. Such a finish can be tested several times until all the layers have been removed from the leather. It would be advisable for specifications to make allowance for this fact.

A strip of hard PVC is used as the adherent-plate; this gives good adhesion under wet conditions. Wet adhesion can therefore be measured easily. Experience has shown that this “real” wet-adhesion value is often lower, a fact that must also be considered when drawing up specifications based on this method.

ITEH STANDARD PREVIEW  
(standards.iteh.ai)

[ISO 11644:2009](https://standards.iteh.ai/catalog/standards/sist/5ea84e58-3bb1-4905-b856-a1a7aaed70c/iso-11644-2009)

<https://standards.iteh.ai/catalog/standards/sist/5ea84e58-3bb1-4905-b856-a1a7aaed70c/iso-11644-2009>

**iTeh STANDARD PREVIEW**  
**(standards.iteh.ai)**

ISO 11644:2009

<https://standards.iteh.ai/catalog/standards/sist/5ea84e58-3bb1-4905-b856-a1a7aaed70c/iso-11644-2009>

# Leather — Test for adhesion of finish

## 1 Scope

This International Standard specifies a method for measuring the adhesion of the finish to leather or the adhesion between two adjacent layers of the finish.

The method is valid for all finished leathers with a smooth surface that can be bonded to an adherent-plate without the adhesive penetrating into the finish. Preliminary experiments might be necessary to determine whether these conditions are met.

This test method is valid for finished leathers with a finish-coat thickness of at least 15 µm.

## 2 Normative references

The following referenced documents are indispensable for the application of this document. For dated references, only the edition cited applies. For undated references, the latest edition of the referenced document (including any amendments) applies.

ISO 105-A02, *Textiles — Tests for colour fastness — Part A02: Grey scale for assessing change in colour*  
ISO 11644:2009

ISO 2418, *Leather — Chemical, physical and mechanical and fastness tests — Sampling location*  
<http://standards.iteh.ai/catalog/standards/iso/5e81458-35b1-4005-b85a1a7aaed70c/iso-11644-2009>

ISO 2419, *Leather — Physical and mechanical tests — Sample preparation and conditioning*

ISO 3696, *Water for analytical laboratory use — Specification and test methods*

## 3 Terms and definitions

For the purposes of this document, the following terms and definitions apply.

### 3.1 adhesion

force required to pull the leather away from its surface finish layer, the force being applied steadily, at an angle of about 90°, to a rigid adherent-plate to which the finished side of the leather has been bonded

## 4 Principle

The finished side of part of a strip of leather is bonded to an adherent-plate by means of an adhesive film. Force is applied to the free end of the strip to peel the leather from the finish over a given distance, the finish layer remaining on the adherent-plate together with the film of adhesive. The force required is measured and reported as the adhesion value of the finish.

The test is usually carried out on specimens conditioned in a standard atmosphere before testing. If required, the test may additionally be carried out on wetted specimens or on specimens that have previously been subjected to other treatments.

## 5 Apparatus and materials

5.1 **Tensile-testing machine**, incorporating the following features:

- a) a force range appropriate to the specimen under test;
- b) a uniform speed of separation of the jaws of 100 mm/min  $\pm$  5 mm/min;
- c) suitable means for fixing the adherent-plate holder (5.3) and either the hook link (5.4) or clamp (5.5);
- d) provision for recording a force-distance diagram during the test.

5.2 **Adherent-plate**, comprising a piece of hard poly(vinyl chloride) (PVC), or another suitable material, measuring approximately 70 mm  $\times$  20 mm  $\times$  3 mm, to which the leather specimen is bonded. PVC with a high infrared (IR) absorption is preferred.

5.3 **Adherent-plate holder** (see Figure 1), made of any suitable material, for holding the adherent-plate, to which the leather specimen has been bonded, in the lower clamp of the tensile-testing machine. Optionally, the plates can be held firmly by screws through the sides of the plate holder, see Figure 5.

Dimensions in millimetres

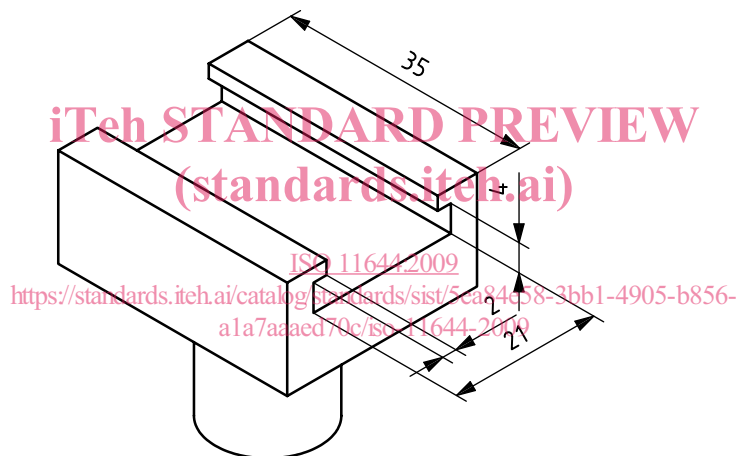

Figure 1 — Adherent-plate holder ( $\pm$  2 mm for 35 mm, otherwise  $\pm$  1 mm)

Either:

5.4 **Hook link**, made of steel wire 1 mm to 2 mm in diameter, at least 200 mm long, for attaching the free end of the leather specimen to the upper clamp of the tensile-testing machine (see Figures 2 and 4). The length of the hook link ensures that the angle of peel always remains close to 90°.

Or:

5.5 **Flat-jawed laboratory screw clamp** (see Figure 3), suitable for clamping the leather sample with a suitable attachment for connecting the laboratory clamp to the upper jaw of the tensile-testing machine, see Figure 5. The length of this attachment should be approximately 250 mm long to ensure that the angle of peel remains close to 90°. Alternatively, a flat-jawed device fitted directly to a tensile-testing machine, such that a peel angle of 90° can be maintained throughout the test, may be used.

5.6 **Punch**, suitable for making a hole 2 mm to 3 mm in diameter in the leather specimen, if using the hook link (5.4).



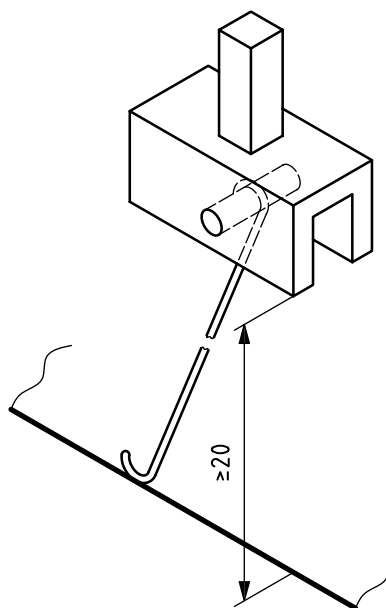

Figure 2 — Hook link

iTeh STANDARD PREVIEW  
(standards.itech.ai)

<https://standards.itech.ai/catalog/standards/sist/7ea84e58-3bb1-4905-b856-a1a7aaed376e/iso-11644-2009>



Figure 3 — Flat-jawed clamp

**5.7 Adhesive**, suitable for bonding the leather specimen to the adherent-plate. Types of adhesives found to give satisfactory, reproducible results are

- a single-component cyanoacrylate adhesive, of the instant adhesive type that hardens and bonds within a very short time to avoid penetration of the adhesive through the finish layer, and
- a two-component polyurethane adhesive, comprising a resin and a hardener.

For the two-component adhesive, usually 20 g of solid resin is dissolved in 80 g of ethyl acetate and 5 g of hardener is added, unless otherwise instructed by the supplier of the adhesive. The adhesive shall be used within 8 h of adding the hardener, unless otherwise instructed by the supplier.

NOTE Examples of suitable adhesives available commercially are given in Annex A.