



# Standard Test Method for Measuring Softball Bat Performance Factor<sup>1</sup>

This standard is issued under the fixed designation F 1890; the number immediately following the designation indicates the year of original adoption or, in the case of revision, the year of last revision. A number in parentheses indicates the year of last reapproval. A superscript epsilon ( $\epsilon$ ) indicates an editorial change since the last revision or reapproval.

## 1. Scope

1.1 This test method covers a method for determining bat performance by measuring the bat-ball coefficient of restitution (BBCOR), deriving the bat performance factor (BPF) and calculating a batted ball speed (BBS). It is applicable to softball bats of any construction or material. The method provides a quantitative measure of bat dynamic performance that may be used for comparison purposes.

1.2 The BBCOR, BPF, and BBS are each calculated from measurements taken in the laboratory on test equipment meeting the requirements defined in this specification.

1.3 The values stated in inch-pound units are to be regarded as the standard.

1.4 *This standard does not purport to address all of the safety concerns, if any, associated with its use. It is the responsibility of the user of this standard to establish appropriate safety and health practices and determine the applicability of regulatory requirements prior to use.*

## 2. Referenced Documents

### 2.1 ASTM Standards:<sup>2</sup>

**F 1887** Test Method for Measuring the Coefficient of Restitution (COR) of Baseballs and Softballs

**F 1888** Test Method for Compression-Displacement of Baseballs and Softballs

**F 2398** Test Method for Measuring Moment of Inertia and Center of Percussion of a Baseball or Softball Bat

## 3. Terminology

### 3.1 Definitions of Terms Specific to This Standard:

3.1.1 *balance point, n*—distance to the center of mass of a bat when measured from the distal end of the bat knob.

3.1.2 *bat-ball coefficient of restitution (BBCOR), n*—COR of a specific ball colliding with a bat as defined in this test method. See *coefficient of restitution (COR)*.

3.1.3 *bat performance factor (BPF), n*—ratio of BBCOR to ball COR as defined in this test method.

3.1.4 *center of percussion (COP), n*—also known as the center of oscillation, the length of a simple pendulum with the same period as a physical pendulum, as in a bat oscillating on a pivot. Forces and impacts at this location will not induce axial reactions at the pivot point.

3.1.5 *coefficient of restitution (COR), n*—measure of impact efficiency calculated as the relative speed of the objects after impact divided by the relative speed of the objects before impact.

3.1.6 *moment of inertia (MOI), n*—measure of mass distribution relative to an axis of rotation. It is the product of the mass multiplied by the square of the distance to the mass, summed over the entire bat.

## 4. Significance and Use

4.1 This test method offers a laboratory means to compare the performance of a softball bat.

4.2 Use of this test method can provide sports governing bodies a means to compare calculated BBS and other physical properties of bats.

## 5. Apparatus

5.1 *Test Balls*—Official softballs approved for play and tested in accordance with the following procedures. Perform ball compression test of Test Method **F 1888** prior to ball COR test of Test Method **F 1887**.

5.1.1 *Compression*—350 to 375 lb at 0.25-in. deflection (1557 to 1668 N at 6.4-mm deflection) in accordance with Test Method **F 1888**. Balls to be labeled with compression value.

5.1.2 *Weight*—6.25 to 6.75 oz (177.2 to 191.4 g). Balls to be labeled with weight value.

5.1.3 *Size*—12.00 to 12.25-in. (304.8 to 311.1-mm) circumference. Balls to be labeled with size value.

5.1.4 *Core Material*—Polyurethane.

5.1.5 *Ball COR*—0.450 to 0.470 in accordance with Test Method **F 1887**. Balls to be labeled with COR and test speed in ft/s.

5.2 *Bat-Ball COR Test Apparatus:*

5.2.1 *Ball Cannon*—A device capable of shooting a ball at a speed of 88 ft/s. The ball shall not have a spin rate in excess of 10 rpm. Typical pitching machines cannot yield the aiming accuracy required by this test method. Cannon exhaust air must

<sup>1</sup> This test method is under the jurisdiction of ASTM Committee F08 on Sports Equipment and Facilities and is the direct responsibility of Subcommittee F08.26 on Baseball and Softball Equipment.

Current edition approved Oct. 1, 2005. Published November 2005. Originally approved in 1998. Last previous edition approved in 2004 as F 1890 – 04.

<sup>2</sup> For referenced ASTM standards, visit the ASTM website, www.astm.org, or contact ASTM Customer Service at service@astm.org. For *Annual Book of ASTM Standards* volume information, refer to the standard's Document Summary page on the ASTM website.

not cause motion of the bat in the absence of an impact. The ball cannon can be any distance from impact location, as long as it can meet the ball aim requirements and provide six valid impacts in twelve shots or less.

5.2.2 *Bat Speed Gate*—A light trap device, or an equivalent, capable of measuring an edge traveling at speeds of between 5 and 15 ft/s with a resolution of one hundredth of 1 ft/s (0.01 ft/s) with an accuracy of at least  $\pm 1\%$  when the distance between the first and second sensor is between 3 in. (76.2 mm) and 3.6 in. (94.1 mm). The first sensor shall trigger when the bat rotates no less than  $25^\circ$  and no more than  $30^\circ$  from its start position. It is suggested the second trigger be 3 in. (76.2 mm) away from the first and must not be any further than 3.6 in. (91.4 mm) away on a 6-in. (15.24-cm) radius.

5.2.3 *Ball Speed Gate*—A light trap device, or an equivalent, capable of measuring a sphere traveling at speeds in excess of 88 ft/s (26.8 m/s) with an accuracy of 0.5 ft/s (0.2 m/s) or better. The device shall measure across a length of no less than half the ball diameter to avoid centering error. For example, when testing softballs, the device shall sense an object across a 2.0-in. (50.8-mm) line. The first sensor shall trigger when the ball is no more than 12 in. (30.5 cm) from the bat surface. The second sensor shall trigger between 3.6 in. (91.4 mm) and 8 in. (203.2 mm) from the first sensor. The second sensor is located between the first sensor and the bat surface.

5.2.4 *Bat Pivot Support*—A turntable, rotating in the horizontal plane, with clamps to support and align the bat in the path of the ball. The clamp surfaces shall be a  $45^\circ$  Vee clamp with a radius no greater than 2.0 in. (50.8 mm). The rotating clamp and shaft assembly shall not weigh more than 6 lb (2.7 kg) and shall spin freely via ball bearings (see Fig. 1). The polar MOI for the clamp turntable assembly shall not exceed 192 oz-in.<sup>2</sup> (35 117 g-cm<sup>2</sup>). The actual MOI of the clamp turntable assembly shall be determined and used in the performance calculations.

## 6. Calibration and Standardization

6.1 *Ball Speed Gate*—The distances between the sensors of the speed gates must be known and recorded to the stated tolerances. The accuracy of the timers used in the velocity sensors must be adequate to provide the stated velocity

accuracy at maximum stated speeds. The timers used shall be calibrated on at least a yearly basis.

6.2 *Reference Standards and Blanks*—A standard bat and ball shall be used for reference purposes to verify proper machine operation.

## 7. Conditioning

### 7.1 Ball and Bat Conditioning:

7.1.1 Balls shall be placed in an environmentally controlled space for at least 14 days immediately before testing. Wood bats shall be stored at these environmental conditions for at least 24 h prior to testing. Non-wood bats shall be stored at these environmental conditions for at least 2 h prior to testing.

7.1.2 Temperature is to be maintained at  $72 \pm 4^\circ\text{F}$  ( $22 \pm 2^\circ\text{C}$ ).

7.1.3 Relative humidity is to be maintained at  $50 \pm 10\%$ .

7.1.4 Ball and bat tests should be completed within 1 h of removal from controlled area.

### 7.2 Test Room Conditions:

7.2.1 The test room shall be controlled environmentally.

7.2.2 Temperature is to be maintained at  $72 \pm 4^\circ\text{F}$  ( $22 \pm 2^\circ\text{C}$ ).

7.2.3 Relative humidity is to be maintained between 20 and 60 %.

## 8. Procedure

8.1 *Determination of Bat Features and Test Location*—Determine bat balance point (BP), bat MOI, and bat COP in accordance with Test Method F 2398.

### 8.2 Bat Test Procedure:

8.2.1 Ready and calibrate ball and bat speed gates in accordance with the manufacturer's instructions.

8.2.2 Select a test ball in accordance with 5.1, and record the actual values of compression, weight, size, and COR of the ball in accordance with 5.1.

8.2.3 Set ball cannon to fire the ball at the desired impact speed of 88 ft/s (26.8 m/s). Valid test speeds are considered to be those within  $\pm 1\%$  of the targeted test speed.

8.2.4 Mount bat in the clamps on the bat pivot support. The distal end of the bat knob must be 6 in. (152.4 mm) from the axis of rotation of the turntable assembly.

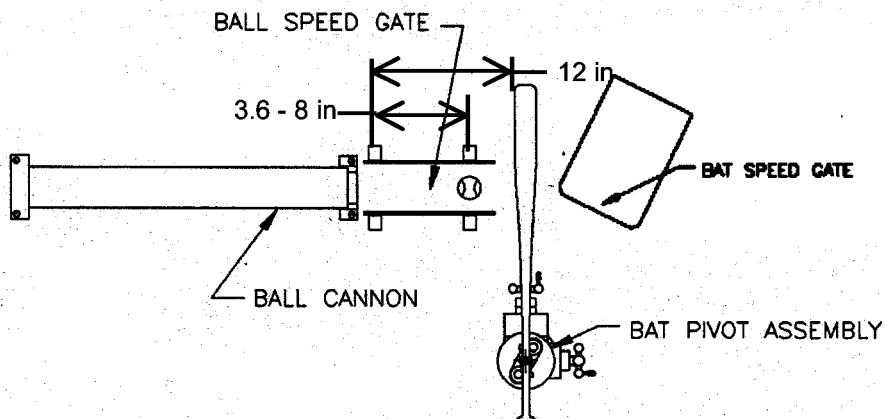

FIG. 1 Bat Testing Machine