



Designation: D130 – 04<sup>ε1</sup>

Federation of Societies for  
Paint Technology Standard No. Dt-28-65  
British Standard 4351



Designation: 154/93

## Standard Test Method for Corrosiveness to Copper from Petroleum Products by Copper Strip Test<sup>1</sup>

This standard is issued under the fixed designation D130; the number immediately following the designation indicates the year of original adoption or, in the case of revision, the year of last revision. A number in parentheses indicates the year of last reapproval. A superscript epsilon ( $\epsilon$ ) indicates an editorial change since the last revision or reapproval.

*This standard has been approved for use by agencies of the Department of Defense.*

<sup>ε1</sup> NOTE—Paragraphs 11.1.2 and 11.1.3 were editorially corrected to match Table 1 and ADJD0130.

### 1. Scope

1.1 This test method covers the determination of the corrosiveness to copper of aviation gasoline, aviation turbine fuel, automotive gasoline, cleaners (Stoddard) solvent, kerosine, diesel fuel, distillate fuel oil, lubricating oil, and natural gasoline or other hydrocarbons having a vapor pressure no greater than 124 kPa (18 psi) at 37.8°C. (**Warning**—Some products, particularly natural gasoline, may have a much higher vapor pressure than would normally be characteristic of automotive or aviation gasolines. For this reason, exercise extreme caution to ensure that the pressure vessel used in this test method and containing natural gasoline or other products of high vapor pressure is not placed in the 100°C (212°F) bath. Samples having vapor pressures in excess of 124 kPa (18 psi) may develop sufficient pressures at 100°C to rupture the pressure vessel. For any sample having a vapor pressure above 124 kPa (18 psi), use Test Method D1838.)

1.2 The values stated in SI units are to be regarded as the standard. The values in parentheses are for information only.

1.3 *This standard does not purport to address all of the safety concerns, if any, associated with its use. It is the responsibility of the user of this standard to establish appropriate safety and health practices and determine the applicability of regulatory requirements prior to use. For specific warning statements, see 1.1, 6.1, and Annex A2.*

<sup>1</sup> This test method is under the jurisdiction of ASTM Committee D02 on Petroleum Products and Lubricants and is the direct responsibility of Subcommittee D02.05 on Properties of Fuels, Petroleum Coke and Carbon Material.

Current edition approved May 1, 2004. Published June 2004. Originally approved in 1922, replacing former D89. Last previous edition approved in 2000 as D130-94 (2000) <sup>ε1</sup>.

In the IP, this test method is under the jurisdiction of the Standardization Committee. It is issued under the fixed designation IP 154. The final number indicates the year of last revision.

This test method has been approved by the sponsoring committees and accepted by the cooperating societies in accordance with established procedures. DOI: 10.1520/D0130-04E01.

### 2. Referenced Documents

#### 2.1 ASTM Standards:<sup>2</sup>

D396 Specification for Fuel Oils

D975 Specification for Diesel Fuel Oils

D1655 Specification for Aviation Turbine Fuels

D1838 Test Method for Copper Strip Corrosion by Liquefied Petroleum (LP) Gases

D4057 Practice for Manual Sampling of Petroleum and Petroleum Products

D4177 Practice for Automatic Sampling of Petroleum and Petroleum Products

E1 Specification for ASTM Liquid-in-Glass Thermometers

#### 2.2 ASTM Adjuncts:

ASTM Copper Strip Corrosion Standard<sup>3</sup>

### 3. Summary of Test Method

3.1 A polished copper strip is immersed in a specific volume of the sample being tested and heated under conditions of temperature and time that are specific to the class of material being tested. At the end of the heating period, the copper strip is removed, washed and the color and tarnish level assessed against the ASTM Copper Strip Corrosion Standard.

### 4. Significance and Use

4.1 Crude petroleum contains sulfur compounds, most of which are removed during refining. However, of the sulfur compounds remaining in the petroleum product, some can have a corroding action on various metals and this corrosivity is not

<sup>2</sup> For referenced ASTM standards, visit the ASTM website, [www.astm.org](http://www.astm.org), or contact ASTM Customer Service at [service@astm.org](mailto:service@astm.org). For *Annual Book of ASTM Standards* volume information, refer to the standard's Document Summary page on the ASTM website.

<sup>3</sup> Available from ASTM International Headquarters. Order Adjunct No. ADJD0130. Names of suppliers in the United Kingdom can be obtained from Energy Institute, 61 New Cavendish St., London, W1G 7AR, U.K. Two master standards are held by the IP for reference.

necessarily related directly to the total sulfur content. The effect can vary according to the chemical types of sulfur compounds present. The copper strip corrosion test is designed to assess the relative degree of corrosivity of a petroleum product.

**5. Apparatus**

5.1 *Copper Strip Corrosion Pressure Vessel*, constructed from stainless steel according to the dimensions as given in Fig. 1. The vessel shall be capable of withstanding a test pressure of 700 kPa gage (100 psi). Alternative designs for the vessel's cap and synthetic rubber gasket may be used provided that the internal dimensions of the vessel are the same as those shown in Fig. 1. The internal dimensions of the pressure vessel are such that a nominal 25-mm by 150-mm test tube can be placed inside the pressure vessel.

5.2 *Test Tubes*, of borosilicate glass of nominal 25-mm by 150-mm dimensions. The internal dimensions shall be checked as acceptable by use of a copper strip (see 6.3). When 30 mL of liquid is added to the test tube with the copper strip in it, a minimum of 5-mm of liquid shall be above the top surface of the strip.

5.3 *Test Baths:*

5.3.1 *General*—All test baths shall be able to maintain the test temperature to within  $\pm 1^{\circ}\text{C}$  ( $2^{\circ}\text{F}$ ) of the required test temperature.

5.3.2 *Liquid Bath Used for Submerging Pressure Vessel(s)*—The bath shall be deep enough to submerge one or more pressure vessels (see 5.1) completely during the test. As the bath medium, use water or any liquid that can be satisfactorily controlled to the sample test temperature. The bath shall be fitted with suitable supports to hold each pressure vessel in a vertical position when submerged.

5.3.3 *Bath(s) Used for Test Tubes*—Liquid baths shall be fitted with suitable supports to hold each test tube (see 5.2) in a vertical position to a depth of about 100-mm (4-in.) as measured from the bottom of the test tube to the bath surface. As a liquid bath medium, water and oil have been found satisfactory and controllable at the specified test temperature. Solid block baths shall meet the same temperature control and immersion conditions and shall be checked for temperature measurement (heat transfer) for each product class by running tests on tubes filled with 30 mL of product plus a metal strip of the nominal dimensions given, plus a temperature sensor.

5.4 *Temperature Sensing Device (TSD)*, capable of monitoring the desired test temperature in the bath to within an accuracy of  $\pm 1^{\circ}\text{C}$  or better. The ASTM 12C (12F) (see Specification E1) or IP 64C (64F) total immersion thermometers have been found suitable to use in the test. If used, no more than 10-mm (0.4-in.) of the mercury should extend above the surface of the bath at the test temperature.

5.5 *Polishing Vise*, for holding the copper strip firmly without marring the edges while polishing. Any convenient type of holder (see Appendix X1) may be used provided that the strip is held tightly and that the surface of the strip being polished is supported above the surface of the holder.

5.6 *Viewing Test Tubes*, flat glass test tubes, are convenient for protecting corroded copper strips for close inspection or storage (see Appendix X1 for the description of a flat-glass

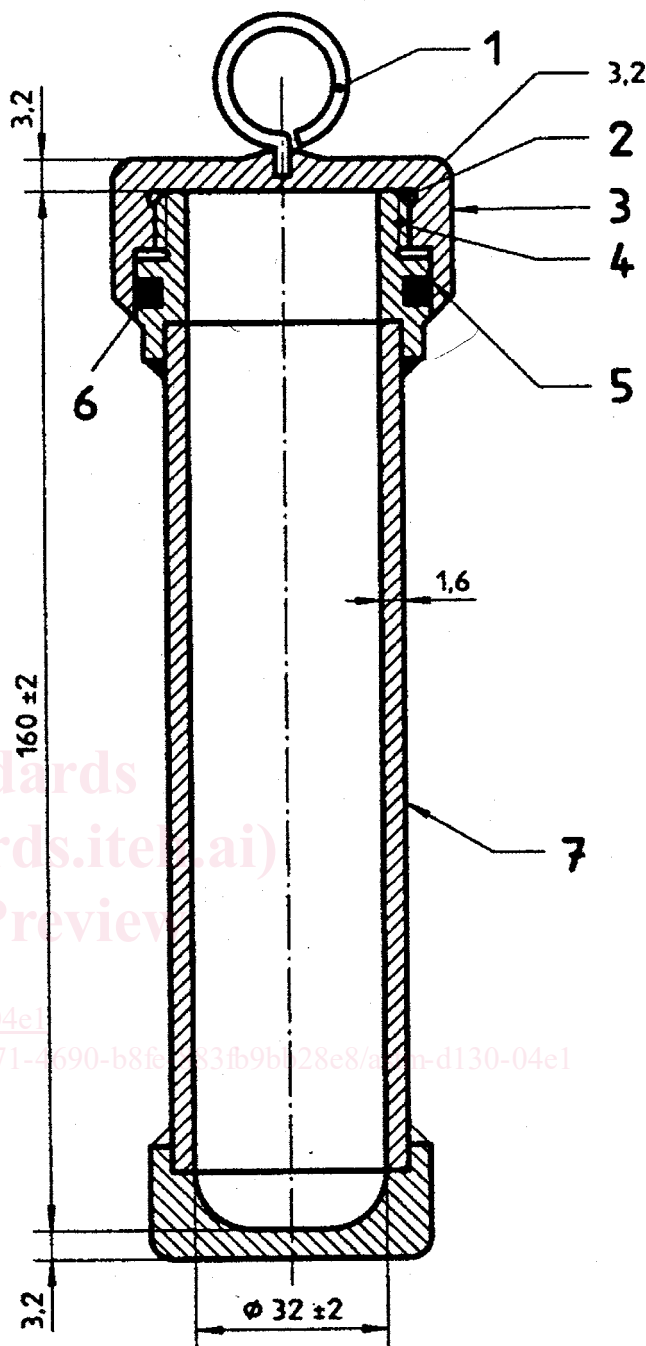

- Key:
- 1 Lifting eye
  - 2 Wide groove for pressure relief
  - 3 Knurled cap
  - 4 Twelve threads per inch NF thread or equivalent
  - 5 Camber inside cap to protect "O" ring when closing pressure vessel
  - 6 Synthetic rubber "O" ring without free sulfur
  - 7 Seamless tube

Material: stainless steel  
 Welded construction  
 Maximum test gage pressure: 700 kPa

NOTE 1—Dimensions in millimetres.  
 NOTE 2—All dimensions without tolerance limits are nominal values.

**FIG. 1 Pressure Vessel for Copper Strip Corrosion Test**

viewing tube). The viewing test tube shall be of such dimensions as to allow the introduction of a copper strip (see 6.3) and made of glass free of striae or similar defects.

5.7 *Forceps*, with either stainless steel or polytetrafluoroethylene (PTFE) tips, for use in handling the copper strips, have been found suitable to use.

5.8 *Timing Device*, electronic or manual, capable of accurately measuring the test duration within the allowable tolerance.

## 6. Reagents and Materials

6.1 *Wash Solvent*—Any volatile, less than 5 mg/kg sulfur hydrocarbon solvent may be used provided that it shows no tarnish at all when tested for 3 h at 50°C (122°F). 2,2,4-trimethylpentane (isooctane) of minimum 99.75 % purity is the referee solvent and should be used in case of dispute. (**Warning**—extremely flammable, see A2.1.)

6.2 *Surface Preparation/Polishing Materials*, 00 grade or finer steel wool or silicon carbide grit paper or cloth of varying degrees of fineness including 65- $\mu$ m (240-grit) grade; also a supply of 105- $\mu$ m (150-mesh) size silicon carbide grain or powder and absorbent cotton (cotton wool). A commercial grade is suitable, but pharmaceutical grade is most commonly available and is acceptable.

6.3 *Copper Strips Specification*—Use strips approximately 12.5-mm (1/2-in.) wide, 1.5 to 3.0-mm (1/16 to 1/8-in.) thick, cut approximately 75-mm (3-in.) long from smooth-surfaced, hard-temper, cold-finished copper of 99.9 + % purity; electrical bus bar stock is generally suitable (see Annex A1). The strips may be used repeatedly but should be discarded when the strip's surface shows pitting or deep scratches that cannot be removed by the specified polishing procedure, or when the surface becomes deformed.

6.4 *Ashless Filter Paper or Disposable Gloves*, for use in protecting the copper strip from coming in contact with the individual during final polishing.

## 7. ASTM Copper Strip Corrosion Standards<sup>3</sup>

7.1 These consist of reproductions in color of typical test strips representing increasing degrees of tarnish and corrosion, the reproductions being encased for protection in plastic and made up in the form of a plaque.

7.1.1 Keep the plastic-encased ASTM Copper Strip Corrosion Standards protected from light to avoid the possibility of fading. Inspect for fading by comparing two different plaques, one of which has been carefully protected from light (for example, new plaque). Observe both sets in diffused daylight (or equivalent) first from a point directly above and then from an angle of 45°. If any evidence of fading is observed, particularly at the left-hand end of the plaque, it is suggested that the one that is the more faded with respect to the other be discarded.

7.1.1.1 Alternatively, place a suitably sized opaque strip (for example, 20-mm (3/4-in.) black electrical tape) across the top of the colored portion of the plaque when initially purchased. At intervals remove the opaque strip and observe. When there is any evidence of fading of the exposed portion, the standards shall be replaced.

7.1.1.2 These plaques are full-color reproductions of typical strips. They have been printed on aluminum sheets by a 4-color process and are encased in plastic for protection. Directions for their use are given on the reverse side of each plaque.

7.1.2 If the surface of the plastic cover shows excessive scratching, it is suggested that the plaque be replaced.

## 8. Samples

8.1 In accordance with D4057 or D4177, or both, it is particularly important that all types of fuel samples, that pass a low-tarnish strip classification, be collected in clean, dark glass bottles, plastic bottles, or other suitable containers that will not affect the corrosive properties of the fuel. Avoid the use of tin plate containers for collection of samples, since experience has shown that they may contribute to the corrosiveness of the sample.

8.2 Fill the containers as completely as possible and close them immediately after taking the sample. Adequate headspace in the container is necessary to provide room for possible thermal expansion during transport. It is recommended that volatile samples be filled between 70 and 80 % of the container's capacity. Take care during sampling to protect the samples from exposure to direct sunlight or even diffused daylight. Carry out the test as soon as possible after receipt in the laboratory and immediately after opening the container.

8.3 If suspended water (that is, haze) is observed in the sample, dry by filtering a sufficient volume of sample through a medium rapid qualitative filter, into the prescribed clean, dry test tube. Carry out this operation in a darkened room or under a light-protected shield.

8.3.1 Contact of the copper strip with water before, during or after completion of the test run will cause staining, making it difficult to evaluate the strips.

## 9. Preparation of Test Strips

9.1 *Surface Preparation*—Remove all surface blemishes from all six sides of the strip obtained from a previous analysis (see Note 1). One way to accomplish this is to use 00 grade or finer steel wool or silicon carbide paper or cloth of such degrees of fineness as are needed to accomplish the desired results efficiently. Finish with 65- $\mu$ m (240-grit) silicon carbide paper or cloth, removing all marks that may have been made by other grades of paper used previously. Ensure the prepared copper strip is protected from oxidation prior to final preparation, such as by immersing the strip in wash solvent from which it can be withdrawn immediately for final preparation (polishing) or in which it can be stored for future use.

NOTE 1—Only final preparation (9.2) is necessary for commercially purchased pre-polished strips.

9.1.1 As a practical manual procedure for surface preparation, place a sheet of silicon carbide paper or cloth on a flat surface and moisten it with kerosine or wash solvent. Rub the strip against the silicon carbide paper or cloth with a circular motion, protecting the strip from contact with the fingers by using ashless filter paper or wearing disposable gloves. Alternatively, the surface of the strip can be prepared by use of motor-driven machines using appropriate grades of dry paper or cloth.

**9.2 Final Preparation**—For strips prepared in 9.1 or new strips being used for the first time, remove a strip from its protected location, such as by removing it from the wash solvent. To prevent possible surface contamination during final preparation, do not allow fingers to come in direct contact with the copper strips, such as by wearing disposable gloves or holding the strips in the fingers protected with ashless filter paper. Polish first the ends and then the sides with the 105-mm (150-mesh) silicon carbide grains picked up with a pad of cotton (cotton wool) moistened with wash solvent. Wipe vigorously with fresh pads of cotton (cotton wool) and subsequently handle without touching the surface of the strip with the fingers. Forceps have been found suitable to use. Clamp in a vise and polish the main surfaces with silicon-carbide grains on absorbent cotton. Do not polish in a circular motion. Rub in the direction of the long axis of the strip, carrying the stroke beyond the end of the strip before reversing the direction. Clean all metal dust from the strip by rubbing vigorously with clean pads of absorbent cotton until a fresh pad remains unsoiled. When the strip is clean, immediately immerse it in the prepared sample.

**9.2.1** It is important to polish the whole surface of the strip uniformly to obtain a uniformly stained strip. If the edges show wear (surface elliptical), they will likely show more corrosion than the center. The use of a vise (see [Appendix X1](#)) will facilitate uniform polishing.

**9.2.2** It is important to follow the order of preparation with the correctly sized silicon carbide material as described in 9.1 and 9.2. The final preparation is with 105- $\mu\text{m}$  silicon carbide powder. This is a larger grain size than the 65- $\mu\text{m}$  paper used in the surface preparation stage. The reason for this use of larger silicon carbide grains in the final preparation is to produce asperities (controlled roughness) on the surface of the copper, which act as sites for the initiation of corrosion reactions.

## 10. Procedure

**10.1 General**—There are a variety of test conditions, which are broadly specific to given classes of product but, within certain classes, more than one set of test conditions of time or temperature, or both, may apply. In general, aviation gasoline shall be tested in a pressure vessel at 100°C and other high vapor pressure fuels, like natural gasoline, at 40°C. Other liquid products shall be tested in a test tube at 50°C, 100°C or even higher temperatures. The conditions of time and temperature given below are commonly used and are quoted in the ASTM specifications for these products where such specifications exist. They are, however, guides only. Other conditions can also be used when required by specifications or by agreement between parties. The test conditions of time and temperature shall be recorded as part of the result (see 12.1).

**10.2 Pressure Vessel Procedure**—For use with aviation gasoline and higher vapor pressure samples.

**10.2.1 For Aviation Gasoline and Aviation Turbine Fuel**—Place 30 mL of sample, completely clear and free of any suspended or entrained water (see 8.3) into a chemically clean and dry 25-mm by 150-mm test tube. Within 1 min after completing the final preparation (polishing), slide the copper strip into the sample tube. Place the sample tube into the

pressure vessel ([Fig. 1](#)) and screw the lid on tightly. If more than one sample is to be analyzed at essentially the same time, it is permissible to prepare each pressure vessel in the batch before completely immersing each pressure vessel in the liquid bath at  $100 \pm 1^\circ\text{C}$  ( $212 \pm 2^\circ\text{F}$ ), provided the elapsed time between the first and last samples is kept to a minimum. After  $2 \text{ h} \pm 5 \text{ min}$  in the bath, withdraw the pressure vessel and immerse for a few minutes in cool water (tap water). Open the pressure vessel, withdraw the test tube and examine the strip as described in 10.4.

**10.2.2 For Natural Gasoline**—Carry out the test exactly as described in 10.2.1 but at 40°C (104°F) and for  $3 \text{ h} \pm 5 \text{ min}$ .

**10.3 Test Tube Procedure**—For use with most liquid products.

**10.3.1 For Diesel Fuel, Fuel Oil, Automotive Gasoline**—Place 30 mL of sample, completely clear and free of any suspended or entrained water (see 8.3), into a chemically clean, dry 25-mm by 150-mm test tube and, within 1 min after completing the final preparation (polishing), slide the copper strip into the sample tube. If more than one sample is to be analyzed at essentially the same time, it is permissible to prepare each sample in the batch by stoppering each tube with a vented stopper, such as a vented cork before placing each tube in a bath maintained at  $50 \pm 1^\circ\text{C}$  ( $122 \pm 2^\circ\text{F}$ ), provided the elapsed time between the first and last sample prepared is kept to a minimum. Protect the contents of the test tube from strong light during the test. After  $3 \text{ h} \pm 5 \text{ min}$  in the bath, examine the strip as described in 10.4. For tests on fuel oil and diesel fuel, to specifications other than Specifications [D396](#) and [D975](#), a temperature of 100°C (212°F) for 3 h is often used as an alternative set of conditions. Some automotive gasolines with vapor pressure above 80 kPa at 37.8°C have exhibited evaporation losses in excess of 10 % of their volume. If such evaporation losses are apparent, it is recommended that the Pressure Vessel Procedure (see 10.2) be used.

**10.3.2 For Cleaners (Stoddard) Solvent and Kerosine**—Carry out the test exactly as described in 10.3.1 but at  $100 \pm 1^\circ\text{C}$  ( $212 \pm 2^\circ\text{F}$ ).

**10.3.3 For Lubricating Oil**—Carry out the test exactly as described in 10.3.1, but the tests can be carried out for varying times and at elevated temperatures other than 100°C (212°F). For the sake of uniformity, it is suggested that even increments of 5°C, beginning with 150°C, be used.

### 10.4 Strip Examination:

**10.4.1** Empty the contents of the test tube into a suitably sized receiver. If a receiver made out of glass is used, such as a 150-mL tall-form beaker, let the strip slide in gently so as to avoid breaking the glass. Immediately withdraw the strip with forceps and immerse in wash solvent. Withdraw the strip at once, dry and inspect for evidence of tarnishing or corrosion by comparison with the Copper Strip Corrosion Standards. The step of drying the strip may be done by blotting with filter paper, air drying, or by other suitable means. Hold both the test strip and the standard strip plaque in such a manner that light reflected from them at an angle of approximately 45° will be observed.

**10.4.2** In handling the test strip during the inspection and comparison, the danger of marking or staining can be avoided