



Designation: D 3737 – 05

## Standard Practice for Establishing Allowable Properties for Structural Glued Laminated Timber (Glulam)<sup>1</sup>

This standard is issued under the fixed designation D 3737; the number immediately following the designation indicates the year of original adoption or, in the case of revision, the year of last revision. A number in parentheses indicates the year of last reapproval. A superscript epsilon ( $\epsilon$ ) indicates an editorial change since the last revision or reapproval.

### 1. Scope

1.1 This practice covers the procedures for establishing allowable properties for structural glued laminated timber. Included are the allowable stresses for bending, tension and compression parallel to the grain, horizontal shear, compression perpendicular to the grain, and radial tension and compression in curved members. Also included are modulus of elasticity and modulus of rigidity.

1.2 This practice is limited to the calculation of allowable properties subject to the given procedures for the selection and arrangement of grades of lumber of the species considered.

1.3 Requirements for production, inspection and certification are not included, but in order to justify the allowable properties developed using procedures in this practice, manufacturers must conform to recognized manufacturing standards. Refer to [ANSI/AITC A190.1](#) and [CSA 0122](#).

1.4 The values stated in inch-pound units are to be regarded as standard.

1.5 *This standard does not purport to address all of the safety concerns, if any, associated with its use. It is the responsibility of the user of this standard to establish appropriate safety and health practices and determine the applicability of regulatory limitations prior to use.*

### 2. Referenced Documents

2.1 *ASTM Standards:*<sup>2</sup>

[D 9](#) Terminology Relating to Wood

[D 198](#) Test Methods of Static Tests of Lumber in Structural Sizes

[D 245](#) Practice for Establishing Structural Grades and Related Allowable Properties for Visually Graded Lumber

[D 2395](#) Test Methods for Specific Gravity of Wood and Wood-Based Materials

[D 2555](#) Test Methods for Establishing Clear Wood Strength Values

[D 2915](#) Practice for Evaluating Allowable Properties for Grades of Structural Lumber

[D 4761](#) Test Methods for Mechanical Properties of Lumber and Wood-Base Structural Material

[D 5456](#) Specification for Evaluation of Structural Composite Lumber Products

[D 6570](#) Practice for Assigning Allowable Properties for Mechanically-Graded Lumber

[E 105](#) Practice for Probability Sampling of Materials

2.2 *Other Standards:*

[ANSI/AITC A190.1](#) Structural Glued Laminated Timber<sup>3</sup>

[ANSI/AF&PA](#) National Design Specification for Wood Construction<sup>4</sup>

[CSA 0122](#) Structural Glued Laminated Timber<sup>5</sup>

### 3. Terminology

3.1 *Definitions:*

3.1.1 *Alternative lumber*—laminated veneer lumber (LVL), laminated strand lumber (LSL), oriented strand lumber (OSL), or parallel strand lumber (PSL) meeting the requirements of Specification [D 5456](#), or solid-sawn lumber that is produced according to Practice [D 6570](#) and the grading rules of the applicable grading or inspection agency.

3.1.2 *E-rated lumber*—lumber graded for use in manufacturing structural glued laminated timber by nondestructive measurement of a modulus of elasticity ( $E$ ) and by visual inspection in accordance with the grading rules of the applicable grading or inspection agency.

3.1.3 *glulam*—a term used to denote structural glued laminated timber, which is a product made from suitably selected

<sup>1</sup> This practice is under the jurisdiction of ASTM Committee D07 on Wood and is the direct responsibility of Subcommittee D07.02 on Lumber and Engineered Wood Products.

Current edition approved Oct. 1, 2005. Published November 2005. Originally approved in 1978. Last previous edition approved in 2004 as D 3737 – 04.

<sup>2</sup> For referenced ASTM standards, visit the ASTM website, www.astm.org, or contact ASTM Customer Service at service@astm.org. For *Annual Book of ASTM Standards* volume information, refer to the standard's Document Summary page on the ASTM website.

<sup>3</sup> Available from the American Institute of Timber Construction, 7012 S. Revere Parkway Suite 140, Englewood, CO 80112.

<sup>4</sup> Available from American Forest and Paper Association (AF&PA), 1111 19th St., NW, Suite 800, Washington, DC 20036.

<sup>5</sup> Available from Canadian Standards Association (CSA), 178 Rexdale Blvd., Toronto, ON Canada M9W1R3.

and prepared pieces of wood bonded together with an adhesive either in a straight or curved form with the grain of all pieces essentially parallel to the longitudinal axis of the member.

3.1.4 *horizontally laminated timber*—a member designed to resist bending loads applied perpendicularly to the wide faces of the laminations (referred to as bending about the  $x$ - $x$  axis).

3.1.5 *lamination*—a layer of lumber within the glued laminated timber.

3.1.6 *modulus of elasticity ( $E$ )*—for laminating,  $E$  is designated in two categories to distinguish mode of measurement and application.

3.1.6.1 *Long-Span  $E$  ( $LSE$ )*—the *modulus of elasticity* calculated from deflection measured in a flat-wise static bending test of lumber with a center point loading and a span-to-depth ratio ( $l/d$ ) of approximately 100 or the  $E$  obtained from Test Methods **D 2555** and multiplying by the appropriate factors from **Table 1** and **Table 6**.

3.1.6.2 *Member  $E$  ( $E_{axial}$ ,  $E_x$ ,  $E_y$ )*—the allowable *modulus of elasticity* values of the structural glued laminated member as defined in this practice.

3.1.7 *vertically laminated timber*—a member designed to resist bending loads applied parallel to the wide faces of the laminations (referred to as bending about the  $y$ - $y$  axis).

3.1.8 *visually graded lumber*—lumber graded by visual inspection in accordance with the grading rules of the applicable grading or inspection agency.

3.1.9 *GDE*—the ratio of the cross-sectional area of the local grain deviation (which may or may not be associated with a knot) at the edge of the lumber to the cross sectional area of the lumber (see **Fig. 1**).

3.1.10 *GDC*—the ratio of the cross-sectional area of the local grain deviation (which may or may not be associated with a knot) away from the edge of the lumber to the cross sectional area of the lumber (see **Fig. 1**).

3.1.11 *GDS*—the projected sum of all *GDE* and *GDC* values within a one-foot length of lumber as defined in **Fig. 1**.

3.1.12 *KE*—the ratio of cross-sectional area of a knot at the edge of wide face of lumber to the cross-sectional area of the lumber (see **Fig. 2**).

3.1.13 *KC*—the ratio of the cross-sectional area of a knot located away from the edge of the lumber to the cross-sectional area of lumber. When a knot at the edge of the wide face and a knot located away from the edge are in the same cross-section, the combination of the two shall be used in determining *KC* (see **Fig. 2**).

3.1.14 *SR<sub>fl</sub>*—the required strength ratio of the tension lamination at the outermost fiber.

## 4. Materials Requirements

### 4.1 Requirements for Laminations

4.1.1 Laminations of structural glued laminated timber shall be of lumber with net thickness of 2 in. (0.05 m) or less.

4.1.2 Lumber is permitted to be joined end to end with structural end joints to form long length laminations. End joints shall be qualified and quality controlled with a recognized manufacturing standard.

4.1.3 Lumber is permitted to be placed or joined side to side to form wide laminations.

4.1.4 Dimension lumber used to form laminations shall be visually graded or  $E$ -rated according to established grading rules.

4.1.5 Alternate lumber material is permitted by demonstrating equivalence to a dimension lumber grade in accordance with Annex A.

4.1.6 For the analysis of a structural glued laminated timber layup, all laminations in a single cross section shall be of equal thickness.

4.1.7 The analytical procedures of this standard practice are based on specific lamination characteristics.

4.1.7.1 Lumber properties including knot size and frequency; physical properties such as specific gravity; and mechanical properties such as modulus of elasticity shall be based on measurements of 2×6 lumber for definition of grade characteristics.

4.1.7.2 The effect of decay or compression failures upon strength cannot be readily determined, thus these defects shall be prohibited from laminating grades insofar as existing inspection and grading technology permit. Firm white speck or light white pocket is permissible in grades of lumber that permit knots to occupy up to one third or more of the cross section provided their extent in combination with knots does not exceed that of the largest edge knot permitted. The exception is that firm white speck and light white pocket shall be excluded from end joints in tension members and the outer 10 % of the total depth on the tension side of bending members.

4.1.7.3 Compression wood (as defined in Terminology **D 9**) in readily identifiable and damaging form shall be limited in accordance with **4.1.7.3(1)** and **4.1.7.3(2)**.

(1) For dry service conditions, grades permitting knots up to one half of the cross section may contain streaks of compression wood occupying as much as 20 % of the cross section. Streaks of compression wood up to one eighth of the cross section may be permitted in other grades.

(2) For wet service conditions, or for pressure-treated members, the conditions of **4.1.7.3(1)** apply except that compression wood is limited to 5 % of the cross section of the laminations in tension members and in the outer 10 % of the total depth on the tension side of bending members.

4.1.7.4 Lumber shall be free of shakes and splits that make an angle of less than 45° with the wide face of the piece. Pitch pockets shall be limited in size to the area of the largest knot permitted, and pitch streaks shall be limited to one sixth of the width of the lumber.

4.1.7.5 The range of moisture content of lumber for assembly into a single member shall not exceed five percentage

**TABLE 1 Adjustment Factors for Clear Wood Stresses**  
(Test Methods **D 2555**)

Property	Multipliers for Average or 5th Percentile		Seasoning Factor for a 12 % Average Moisture Content
	Softwoods	Hardwoods	
Bending	0.476	0.435	1.35
Compression parallel to grain	0.526	0.476	1.75
Modulus of elasticity	1.095	1.095	1.20
Horizontal shear	0.244	0.222	1.13

**TABLE 2 Bending Stress Index Based on Large Beam Tests and Modulus of Elasticity Values for Visually Graded Lumber**

NOTE 1—Appendix X1 provides one method of developing new data.

Species	Growth Classification <sup>A</sup>	Bending Stress Index <sup>B</sup>		Modulus of Elasticity	
		psi	MPa	million psi	MPa
Douglas Fir-Larch	medium grain	3000	20.7	1.9	13 100
	close grain	3250	22.4	2.0	13 800
	dense	3500	24.1	2.1	14 500
Southern Pine	coarse grain <sup>C</sup>	2000	13.8	1.5	10 300
	medium grain	3000	20.7	1.8	12 400
	dense	3500	24.1	2.0	13 800
Hem-Fir	medium grain	2560	17.7	1.7	11 700
	dense <sup>D</sup>	3000	20.7	1.8	12 400

<sup>A</sup> Classification for “dense” wood shall follow Practice D 245.

<sup>B</sup> Values shown are based on full-size beam tests. As a result, these values incorporate the effects of some features such as grain deviations in lumber along with influences of end and face bonding influences. Beams designed using these values and tested in accordance with Test Methods D 198 will yield strength values such that the lower fifth percentile will exceed the design bending stress by a factor of 2.1 with 75 % confidence. Analysis of test data assumed a log normal distribution. For unsymmetric combinations, tests have shown that values up to 40 % higher than those listed may be applied to the compression side of bending members.

<sup>C</sup> Also applicable to minor species of southern pine regardless of growth rate.

<sup>D</sup> Specific gravity, based on oven-dry weight and volume at 12 % moisture content, must equal or exceed 0.39.

**TABLE 3 Bending Stress Indexes and Compression Stress Index Parallel to Grain for E-Rated Lumber Used in Laminating<sup>A</sup>**

Long Span, <i>E</i> , psi	Bending Stress Index <sup>A</sup>		Compression Stress Index Parallel to Grain <sup>B,C</sup>	
	psi	MPa	psi	MPa
1 600 000	2560	17.7	1900	13.1
1 900 000	3000	20.7	2400	16.5
2 100 000	3500	24.1	2800	19.3
2 300 000	4000	27.6	3100	21.4

<sup>A</sup> Values shall be not higher than obtained by interpolation for intermediate *E* values.

<sup>B</sup> Values are for 12-in. deep members at 12 % moisture content (dry).

<sup>C</sup> Values are for members at 12 % moisture content (dry) values.

**TABLE 4 Parallel to Grain Stress Modification Factors Associated with Slope of Grain for Designing Glulam Combinations**

Slope of Grain	Stress Modification Factor	
	Tension	Compression
1:4	0.27	0.46
1:6	0.40	0.56
1:8	0.53	0.66
1:10	0.61	0.74
1:12	0.69	0.82
1:14	0.74	0.87
1:15	0.76	1.00
1:16	0.80	1.00
1:18	0.85	1.00
1:20	1.00	1.00

**TABLE 5 Constant Used to Adjust Vertically Laminated Bending Strength Ratio**

Strength Ratio ( <i>SR</i> <sub>1</sub> )	<i>C</i> <sub>1</sub>
0.45 or greater	1.238
0.40	1.292
0.35	1.346
0.30	1.400
0.26 or less	1.444

points, except when all the lumber is 12 % or lower. The maximum moisture content of individual laminations is 16 %, unless the in-service conditions are wet service and in this case the maximum is 20 %.

**TABLE 6 Grade Adjustment Factors for Modulus of Elasticity**

Bending Strength Ratio <sup>A</sup>	Adjustment Factor
0.55 or greater	1.00
0.45 to 0.54	0.90
0.44 or less	0.80

<sup>A</sup> Determined in accordance with Practice D 245.

## 4.2 Requirements for Adhesives

4.2.1 Adhesives for use in structural glued laminated timber shall be rigid (non-elastomeric) to ensure composite action of the laminations and shall be sufficiently strong to transfer stresses required by the intended use of the member.

4.2.2 Adhesives shall be sufficiently durable to provide bond for the life of the glued laminated member in its expected service environment.

4.3 *Tension Laminations*—for horizontally laminated bending members shall meet the requirements herein.

4.3.1 The results of full-size beam tests reported in Refs (6, 10, and 11)<sup>6</sup> have yielded an empirical relationship between the size of knots in the tension zone and bending strength. This relationship dictates that special grading considerations be applied to the laminations used in the outer 10 % of the beam depth on the tension side. This tension side may exist on the top or bottom of the beam, or both, depending upon loading and support conditions. If horizontally laminated timbers are manufactured without applying these special tension lamination grading considerations, the allowable bending stress shall be reduced by multiplying the allowable stress calculated in 7.2.1.1 by 0.85 if the depth is 15 in. (0.38 m) or less or by 0.75 if the depth exceeds 15 in. (0.38 m).

### 4.3.2 Visually Graded Lumber:

4.3.2.1 Definitions of terms required for calculation of knot and grain deviation restrictions are listed in 3.1.9-3.1.13.

4.3.2.2 Knots and local grain deviations are expressed as a ratio of the cross-sectional area they occupy to the cross-sectional area of the lumber based on the dressed width of the lumber. They are measured using the displacement technique.

<sup>6</sup> The boldface numbers in parentheses refer to a list of references at the end of this practice.

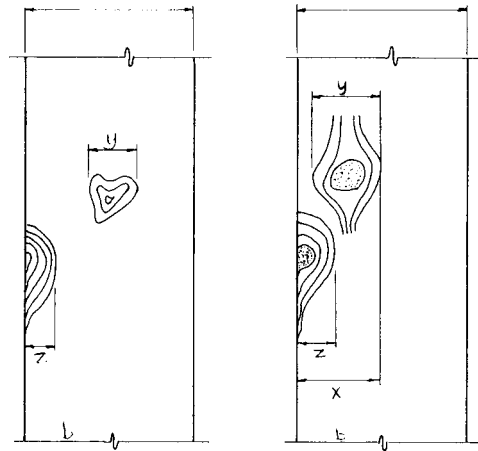

(a)

(b)

$GDC = y/b$

$GDE = z/b$

$GDS = x/b$  where  $x = y + z$

(a) Example of grain deviations not associated with a knot where the projected grain deviations do not overlap.

$GDC = y/b$

$GDE = z/b$

$GDS = x/b$  where  $x < y + z$

(b) Example of grain deviations associated with knots where the projected grain deviations overlap.

FIG. 1 Knot and Grain Deviation Measurement at the Outer 5% on the Tension Side of a Member Occurring in a 1-ft Length

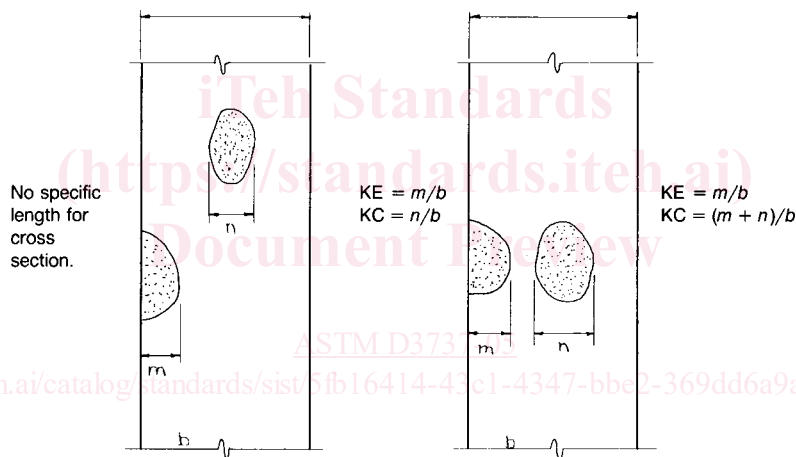

No specific length for cross section.

$KE = m/b$   
 $KC = n/b$

$KE = m/b$   
 $KC = (m + n)/b$

NOTE 1—When edge knots and centerline knots occur at the same cross section, the sum of the edge knots and centerline knots is used in calculating KC as shown in (b).

FIG. 2 Knot Measurement for the Next Inner 5% on the Tension Side of a Bending Member

Knots are measured to the lateral extremes of the knot; grain deviations (with or without knots) are measured to the lateral extremes of the zone within which the local slope of grain exceeds the allowable slope of grain for the grade. Eq 7-10 which follow yield the maximum allowable knot and grain deviation ratios in the outer 10% of depth. It is suggested these ratios be adjusted downward to the nearest 0.05 or to the next nearest convenient fraction (such as 1/3).

4.3.2.3 Beams Greater than 15 in. (0.38 m) in Depth:

(1) Outer 5%—Grain deviation shall be limited in accordance with Eq 1 and 2.

$GDS \leq 1.55(1 - SR_{II})$  (1)

$GDS \leq 1.82(1 - SR_{II})$  (2)

(a) Eq 1 shall be used when GDE, with or without GDC, is used to determine GDS (Fig. 1). Eq 2 shall apply when GDE is not used to determine GDS. In addition, general slope of

grain shall not exceed 1:16 if the required strength ratio of the tension lamination is 0.60 or greater. If  $SR_{II}$  is less than 0.60, the general slope of grain shall not exceed 1:12.

(2) Next Inner 5%—Knots are restricted in accordance with Eq 3 and 4.

$KE = 0.66 - 0.45 SR_{II}$  (3)

$KC = 1.20 - 0.93 SR_{II}$  (4)

(a) General slope of grain shall be limited in accordance with the strength requirements of the individual laminations.

4.3.2.4 Beams 12 in. (0.30 m) to 15 in. (0.38 m) in Depth:

(1) Outer 5%—The requirements of 4.3.2.3(1) apply except that  $SR_{II}$  shall be multiplied by 0.90 in Eq 1 and 2. The value of  $0.9 SR_{II}$  shall not be taken as less than 0.50.

(2) Next Inner 5%—General slope of grain shall be limited in accordance with the strength requirements of the individual laminations.

#### 4.3.2.5 Beams of Four or More Laminations and Less than 12 in. (0.30 m) in Depth:

(1) *Outer 5 %*—The requirements of 4.3.2.3(1) apply except that  $SR_{11}$  shall be multiplied by 0.80 in Eq 1 and 2. The value of 0.80  $SR_{11}$  shall not be taken as less than 0.50.

(2) *Next Inner 5 %*—General slope of grain shall be limited in accordance with the strength requirements of the individual laminations.

#### 4.3.2.6 Density Requirements:

*Outer 5 %*—Density requirements shall apply to the full length of the piece of lumber. In order to ensure that lumber is near-average or above specific gravity for the species, visually graded tension laminations shall have a minimum specific gravity of at least 94 % of the recognized species average from Test Methods D 2555 based on dry weight and volume at 12 % moisture content. The minimum specific gravity of the piece of lumber shall be the average specific gravity of the entire piece. Rate of growth and percentage of latewood requirements for tension laminations shall apply to the full length of lumber. Visual inspection alone is not an acceptable method of determining specific gravity.

#### 4.3.2.7 Other Requirements:

*Outer 5 %*—Wide-ringed or lightweight pith associated wood has a pronounced effect on finger joint strength. The amount of material not meeting rate of growth and density requirements, in combination with compression wood, shall be limited to 1/8 of the cross section of the piece of lumber. In addition, for wet service conditions or pressure-treated members, compression wood is limited to a maximum of 5 % of the cross section.

#### 4.3.3 E-rated Lumber:

##### 4.3.3.1 Grading Requirements:

*Outer 5 %*—In addition to having the required modulus of elasticity, E-rated lumber must meet the requirements for visually graded lumber given in 4.3.2.2, 4.3.2.3(1), and 4.3.2.4(1), with the exception of the knot and slope of grain requirements as given in 4.3.3.3.

##### 4.3.3.2 Other Requirements:

*Outer 5 %*—Wide-ringed or lightweight pith associated wood and compression wood are limited in the same manner as for visually graded lumber, except that there are no density requirements. Material not meeting medium grain rate of growth, in combination with compression wood, shall be limited to 1/8 of the cross section of the piece of lumber. In addition, for wet conditions of use or pressure-treated members, compression wood is limited to a maximum of 5 % of the cross section.

4.3.3.3 The portions of the piece not subjected to mechanical E measurements shall have visual criteria applied to ensure piece quality. Edge knots up to the size permitted in the grade are acceptable. Other knots are limited to the visual requirements of the bending stress index for which the E-rated lumber is qualified. For tension laminations, the slope of grain shall not exceed 1:12 and wide-ringed or pith-associated wood and compression wood is limited as in 4.3.3.2. Medium grain growth requirements shall be met for Douglas Fir-Larch and Southern Pine.

4.3.4 Tension laminations to meet the requirements identified in 4.3.1 may be qualified by test as an alternative to the grading criteria of 4.3.2 and 4.3.3. The procedure given in Annex A1 shall be used.

## 5. Allowable Properties for Glued Laminated Timber Members

5.1 Allowable properties for individual laminations shall be obtained by multiplying the stress index values from Section 6 by the stress modification factors from Section 7 and modifying for specific conditions from Section 8. Allowable properties for glulam members shall be calculated as described in 5.3-5.11.

5.2 Allowable properties shall be rounded to the significant digits as shown in the following table:

Bending, tension parallel to grain, and compression parallel to grain	0 to 1000 psi to nearest 25 psi (0.3 MPa) 1000 to 2000 psi to nearest 50 psi (0.5 MPa) 2000 to 3000 psi to nearest 100 psi (1 MPa)
Horizontal shear	Nearest 5 psi (0.05 MPa)
Compression perpendicular to grain and radial stresses in curved members	Nearest 5 psi (0.05 MPa)
Modulus of Elasticity	Nearest 100 000 psi (500 MPa)

5.3 The allowable bending stress for horizontally laminated timbers shall be calculated as shown by example in Annex A4.

5.4 The allowable bending stress of vertically laminated timbers shall be determined by the following equation:

$$F_{by} = \text{Min} \left\{ \frac{F_{byi}}{E_i} \right\} (E_{avg}) \geq \text{Min} \{ F_{byi} \} \quad (5)$$

where:

$F_{by}$  = allowable bending stress of the vertically laminated beam,

$E_{avg}$  = weighted average of the component lamination LSE values,

$F_{byi}$  = allowable bending stress for the  $i$ th lamination in the combination which is obtained by multiplying the stress index value from 6.1.1 or 6.1.1.1 by the lower of the stress modification factors from 7.2.2.1 and 7.2.2.2 and modifying for specific conditions from Section 8.

$E_i$  = LSE for the  $i$ th lamination.

5.5 *Compression Parallel to Grain*—The allowable stress for compression parallel to grain shall be calculated as shown by example in Annex A5.

5.6 *Tension Parallel to Grain*—The allowable stress for tension parallel to grain shall be the minimum allowable stress of the individual laminations in the member, which is obtained by multiplying the tension stress index from 6.1.3 by the lower of the stress modification factors from 7.4.2 and 7.4.3 and modifying for specific conditions from Section 8.

#### 5.7 Member E:

5.7.1 *Axially Loaded Timbers*—Eaxial shall be the weighted average of the individual lamination grade LSE values modified for specific conditions from Section 8.

5.7.2 *Vertically Laminated Timbers*— $E_y$  shall be 95 % of the weighted average of the individual lamination grade LSE values modified for specific conditions from Section 8.

5.7.3 *Horizontally Laminated Timbers*— $E_x$  shall be 95 % of the apparent modulus of elasticity as determined by a transformed section analysis using the *LSE* values for each grade in the combination modified for specific conditions from Section 8.

#### 5.8 *Horizontal Shear*:

5.8.1 *Horizontally Laminated Timbers*—For horizontally laminated timbers, the allowable stress in horizontal shear shall be the allowable value of the weakest grade in the combination, which is determined by multiplying the shear stress index from 6.1.5 or 6.1.5.1 by the shear stress modification factor from 7.6.1 modified for specific condition from Section 8. Because the test procedure referenced in 6.1.5.1 utilizes prismatic beams subject to static, monotonic loading and produces significantly higher values than the procedure described in 6.1.5, shear stress values determined using 6.1.5.1 shall be limited to straight beams of constant cross section, which are not subject to impact or cyclic loads.

5.8.2 *Vertically Laminated Timbers*—For vertically laminated timbers, the allowable stress in horizontal shear shall be the weighted average of the allowable stresses for the individual laminations, which are determined by multiplying the shear stress index from 6.1.5 or 6.1.5.1 by the appropriate shear stress modification factor from 7.6.2 modified for specific conditions from Section 8. Because the test procedure referenced in 6.1.5.1 utilizes prismatic beams subject to static, monotonic loading and produces significantly higher values than the procedure described in 6.1.5, shear stress values determined using 6.1.5.1 shall be limited to straight beams of constant cross section, which are not subject to impact or cyclic loads.

5.9 *Compression Perpendicular to Grain*—Allowable stresses in compression perpendicular to grain for the glulam member shall be determined based on the location of the applied stress. The allowable stress for the lamination, as determined by multiplying the stress index from 6.1.6 by the stress modification factor from 7.7.1 at the location of the applied stress shall be the allowable stress for the glulam member.

5.10 The modulus of rigidity of glued laminated members can be considered to have a constant relationship to the modulus of elasticity. For design purposes, the relationship  $G = E_x/K$  shall be used for members consisting of a single grade, where  $K = 16$  when specific data is not available. For members consisting of multiple grades of lumber the modulus of rigidity shall be obtained by using the *LSE* of the lowest grade applied to the entire member.

#### 5.11 *Radial Stress in Curved Members*:

5.11.1 *Radial Tension*—The allowable stress for radial tension in curved members shall be equal to the allowable stress for radial tension for the lamination with the lowest value.

5.11.2 *Radial Compression*—The allowable stress for radial compression in curved members shall be equal to the allowable stress for compression perpendicular to the grain for the lamination with the lowest value.

## 6. Stress Index Values for Laminations

6.1 *Visually Graded Lumber*—Test Methods D 2555 provides information on clear wood strength properties and their

expected variation for small clear, straight-grained specimens of green lumber. Based on these clear wood properties, stress index values shall be calculated, unless otherwise permitted herein.

6.1.1 *Bending*—The bending stress index shall be determined by calculating the fifth percentile of modulus of rupture in accordance with Test Methods D 2555, multiplying by the appropriate factors in Table 1, and multiplying by 0.743 to adjust to a 12-in. (0.3-m) deep, uniformly loaded simple beam with a 21:1 span-to-depth ratio.

6.1.1.1 As an alternative to 6.1.1, testing and analysis of large glued laminated timber beams of Douglas Fir-Larch, Southern Pine and Hem-Fir indicate that the stress indices given in Table 2 may be used for Douglas Fir-Larch, grown within the states of Wyoming, Montana, Washington, Idaho, Oregon, and California; for Southern Pine consisting of the four principal species: Longleaf, Slash, Shortleaf, and Loblolly; and for Hem-Fir consisting of Western Hemlock, California Red Fir, Grand Fir, Noble Fir, Pacific Silver Fir and White Fir.

6.1.2 *Compression Parallel to the Grain*—The compression stress index parallel to grain shall be determined by calculating the fifth percentile strength in compression parallel to the grain in accordance with Test Methods D 2555 and multiplying by the appropriate factors from Table 1.

6.1.3 *Tension Parallel to the Grain*—The tension stress index parallel to grain shall be  $\frac{5}{8}$  of the bending stress index obtained in 6.1.1 or 6.1.1.1.

6.1.4 *Modulus of Elasticity*—The stress index value for modulus of elasticity shall be the average long span modulus of elasticity as defined in 3.1.6.1.

6.1.4.1 As an alternative to 6.1.4, values from Table 2 based on testing of large samples of lumber of the species groups listed in 6.1.1.1 and multiplied by appropriate factors from Table 6 are permitted to be used for *LSE*.

6.1.5 *Horizontal Shear*—The horizontal shear stress index shall be the lower fifth percentile of clear wood shear strength, determined in accordance with Practice D 2915 using the data given in Test Methods D 2555 and multiplying by the appropriate factors from Table 1. The horizontal shear stress index for coarse-grain Douglas Fir-Larch and Southern Pine shall be 70 % of the value used for medium-grain materials.

6.1.5.1 As an alternative to 6.1.5, the horizontal shear stress index shall be permitted to be determined from flexural tests of full-size beams in accordance with the principles of Test Methods D 198 with specific loading details as shown in Annex A7. Laminating lumber used in the critical core area of the test beams subjected to maximum shear stresses shall be selected such that it is representative of the population of on-grade lumber used in normal production for the species and grade being evaluated. The required number of samples and the lower 5th percentile tolerance limit of shear strength shall be determined in accordance with Practice D 2915 and the analysis procedures given in Annex A7. The horizontal shear stress index is determined by multiplying the lower 5th percentile tolerance limit of shear strength by 1/2.1. Reassessment of the horizontal shear stress index derived from this section shall be conducted for beam configurations that are not included in the

consideration of the testing described in this section, or if there is a significant change in the lumber resource or in the lamination grading system or the manufacturing process.

6.1.6 *Compression Perpendicular to the Grain*—The stress index value for compression perpendicular to grain shall be determined as follows ((1):

$$F_{C\perp} = (2674 SG - 551.3) (1.9/1.67) \quad (6)$$

where:

$F_{C\perp}$  = stress index value in compression perpendicular to grain, and

$SG$  = average green specific gravity from Test Methods **D 2555** or, for a species group, the standing timber volume weighted average green specific gravity, adjusted as shown in **6.1.6.1**, **6.1.6.2**, or **6.1.6.3**.

6.1.6.1 For purposes of calculating stress index values in compression perpendicular to grain for visually graded material, the average green specific gravity of a species or species group which have an average green specific gravity of 0.36 or above shall be reduced by the following amounts for various rates of growth and density to account for variation in the specific gravities.

Dense grain—0.03
Close grain—0.05
Medium grain—0.06
Coarse grain—0.09

6.1.6.2 When the average green (specific gravity) of a species or species group is 0.35 or less the reductions shall be as follows:

Close grain—0.03
Medium grain—0.04

6.1.6.3 As an alternative to the method specified in 5.6.1 of Practice **D 245**, lumber is permitted to be qualified as dense by weighing. The lumber specific gravity, adjusted to a green condition using Test Methods **D 2395**, Appendix X1 conversion formula, shall meet the reduced specific gravity as specified in **6.1.6.1**. The reduced value shall be used in Eq 2 to determine the stress index value in compression perpendicular to grain.

6.1.7 *Radial Tension*—The stress index for radial tension shall be limited to one third of the value for horizontal shear as determined in accordance with **6.1.5**, except for Douglas Fir-Larch, Hem-Fir, Douglas Fir South, Eastern Spruce, Canadian Spruce Pine, and mixed Softwood Species, which are prescriptively limited to 15 psi (0.10 MPa) for other than wind or earthquake loads. For wind and earthquake loading of all species groups, the allowable stress shall be one-third of the allowable stress for horizontal shear determined in accordance with **6.1.5**.

6.2 *E-Rated Lumber*—This method is based on lumber that has been *E*-rated and visually graded in accordance with **Annex A1**. *E*-rated lumber is designated by the modulus of elasticity and the size of the edge characteristics permitted in the grade such as 1.6E-1/3, etc. Edge characteristics include knots, knot holes, burls, localized grain deviation or decay (partially or wholly) at edges of wide faces.

6.2.1 Bending stress index values for *E*-rated lumber with various *LSE* values are given in **Table 3**.

6.2.2 *Compression Parallel to Grain*—Compression parallel to grain stress index values for *E*-rated laminations shall be as given in **Table 3**.

6.2.3 *Tension Parallel to Grain*—The tension stress index for *E*-rated Laminations shall be 5/8 of the bending stress index obtained in **6.2.1**.

6.2.4 *Modulus of Elasticity*—The stress index for modulus of elasticity for *E*-rated laminations shall be the *LSE* as defined in **3.1.6.1**.

6.2.4.1 *LSE* values shall be permitted to be determined by tests of lumber meeting the criteria of **Annex A2**.

6.2.5 *Horizontal Shear*—The stress index value for horizontal shear for *E*-rated laminations shall be determined in the same manner as for visually graded laminations in **6.1.5** or **6.1.5.1**.

6.2.6 *Compression Perpendicular to Grain*—The stress index in compression perpendicular to grain for *E*-rated laminations shall be determined as follows, using the *LSE* listed in **Table 3** and the growth rate classifications.

(1) *Dense*—If the average *LSE* of the *E*-rated grade equals or exceeds that of the dense classification for the species, the stress index for the dense visual grade of the species or species group per **6.1.6** shall be used.

(2) *Medium Grain*—If the average *LSE* of the *E*-rated grade is less than the average *LSE* of the species or species groups, but not more than 300 000 psi below the average, the stress index determined for medium grain lumber per **6.1.6** shall be used.

(3) *Other*—When the average *LSE* of the *E*-rated grade is less than the average *LSE* of the species or species group minus 300 000 psi, the stress index value shall be determined by using a specific gravity of 0.8 times the average specific gravity of the species in solving Eq 2. (The value obtained is approximately the same as that used for coarse grain lumber.)

6.2.6.1 As an alternative to **6.2.6**, the allowable stress for compression perpendicular to grain is permitted to be determined in accordance with the applicable provisions of Refs (**2-5**).

6.2.7 *Radial Tension*—The stress index in radial tension shall be determined in the same manner as for visually graded laminations in **6.1.7**.

## 7. Stress Modification Factors (SMF) for Laminations

7.1 For some strength properties, knots, slope of grain, and other characteristics may affect the strength and therefore reductions in the stress index values are required. This section discusses the stress modification factors applicable to laminations in structural glued laminated timber.

7.1.1 Special tension lamination grades of lumber as described in **4.3** are required to justify the bending stress modification factors determined in **7.2.1.1**.

7.1.2 Slope of grain stress modification factors shall not be applicable to *E*-rated laminations. However, slope of grain restrictions in **9.2.3.1** for tension laminations in the outer 5 % of bending members shall apply to *E*-rated laminations.

7.2 *Bending Stress Modification Factor*—The bending stress modification factor for each lamination shall be the lower of the two modification factors determined separately on the basis of knots and on the basis of slope of grain.

7.2.1 *Horizontally Laminated Timbers*—The bending stress modification factor for laminations in horizontally laminated timbers ( $SMF_{bx}$ ) shall be the lower of the two stress modification factors determined separately for knots and slope of grain as follows:

7.2.1.1 *Knots*—The bending stress modification factor for knots ( $SMF_{bx\ knots}$ ) shall be determined for the lamination at the outer edge of each grade zone. All laminations in the same grade zone shall be permitted to use the same stress modification factor for knots. Transformed section analysis shall be used to locate the neutral axis of the beam. The “half beam” on each side of the neutral axis shall be considered independently after locating the neutral axis. Knots affect strength less if located in laminations near the neutral axis than in outer laminations. Thus, the influence of knots depends both on their size and position and can be measured by their moment of inertia. Tests of glulam beams have provided an empirical relationship between the ratio  $I_K/I_G$  and bending strength.  $I_K$  is defined as the moment of inertia of all knots within 6 in. (152 mm) of the critical cross section and  $I_G$  is the gross moment of inertia. Knot properties shall be determined following the procedures given in Annex A3 and  $I_K/I_G$  ratios shall be calculated following procedures given in Annex A4. Additional information is given in Refs 6 and 7). The stress modification factor in bending shall be determined from the following relationship:

$$SMF_{bx\ knots} = \left(1 + 3\frac{I_K}{I_G}\right) \left(1 - \frac{I_K}{I_G}\right)^3 \left(1 - \frac{I_K}{2I_G}\right) \quad (7)$$

where:

$SMF_{bx\ knots}$  = bending stress modification factor.

(1) For visually graded laminations, the minimum value of  $SMF_{bx\ knots}$  shall not be less than the strength ratio in flatwise bending as determined by formula X1.2 of Practice D 245.

(2) For E-rated laminations, the minimum value of  $SMF_{bx\ knots}$  shall not be less than the appropriate factor from Table 7.

7.2.1.2 *Slope of Grain*—The bending stress modification factor for slope of grain ( $SMF_{bx\ SOG}$ ) for each lamination shall be as given in Table 4. Stress modification factors given for tension shall apply to laminations in the tension side of bending members while those given for compression shall apply to laminations in the compression side.

7.2.2 *Vertically Laminated Timbers*—The bending stress modification factor for laminations in vertically laminated timbers shall be the lower of the two modification factors determined separately for knots and slope of grain as follows:

7.2.2.1 *Knots*—The bending stress modification factor for knots ( $SMF_{by\ knots}$ ) shall be determined from the following empirical relationship (Ref 8):

$$SMF_{by\ knots} = C_1(SR_1^\gamma) (N^\alpha) (1 - 1.645 \Omega_1 / N^{1/2}) \quad (8)$$

where:

- $C_1$  = empirical constant from Table 5,
- $SR_1$  = strength ratio from Practice D 245 for an individual piece of lumber loaded on edge,
- $\gamma$  = empirical constant equal to 0.81,
- $\alpha$  =  $0.329(1 - 1.049SR_1)$ ,
- $N$  = number of laminations in the member of the same grade or higher up to 5 (for members with five or more laminations of the same grade or higher,  $N = 5$ ), and
- $\Omega_1$  = coefficient of variation (CoV) of bending strength for individual laminations. The applicable CoV for individual laminations of visually graded lumber shall be 0.36. The applicable CoV for E-rated laminations shall be 0.24, except for grades that permit the edge characteristics to occupy up to one half of the cross section: in which case, the coefficient of variation shall be 0.36.

7.2.2.2 *Slope of Grain*—The bending stress modification factor for slope of grain ( $SMF_{by\ SOG}$ ) for each lamination shall be equal to the appropriate slope of grain stress modification factor for tension from Table 4.

7.3 *Stress Modification Factors in Compression Parallel to the Grain:*

7.3.1 The compression stress modification factor ( $SMF_c$ ) for laminations in members with four or more laminations shall be the lower of the two modification factors determined separately from knots and slope of grain as follows:

7.3.2 *Knots*—A single compression stress modification factor for knots ( $SMF_{c\ knots}$ ) shall be determined for the entire cross section.  $SMF_{c\ knots}$  shall be applied to each lamination in the cross section. Tests have shown that the axial compressive strength of short compression members is related to the ratio of the area of knots in the cross section to the gross cross sectional area. Procedures for estimating values of this ratio for compression members are given in Annex A5. The stress modification factor for knots shall be determined from the following empirical relationship.

$$SMF_{c\ knots} = \frac{(A_K / A_G)^3}{4} - (A_K / A_G)^2 - \frac{(A_K / A_G)}{4} + 1 \quad (9)$$

where:

- $SMF_{c\ knots}$  = compression stress modification factor for knots, and
- $A_K/A_G$  = ratio of the area of knots in the cross section to gross cross sectional area as defined in Annex A5.

For members with grades of lumber placed unsymmetrically, an additional adjustment, given in Annex A5, is necessary to compensate for additional bending stresses.

7.3.3 *Slope of Grain*—The compression stress modification factor for slope of grain ( $SMF_{c\ SOG}$ ) for each lamination shall be as given in Table 4.

**TABLE 7 Minimum Bending and Compression Parallel to Grain Stress Modification Factors for Members of E-Rated Lumber**

E-Grade Designation <sup>A</sup>	Minimum Stress Modification Factor (SMF)		
	Horizontally Laminated Bending	Vertically Laminated Bending	Compression Parallel to Grain
1/6	0.80	0.70	0.80
1/4	0.75	0.65	0.75
1/2	0.50	0.25	0.50

<sup>A</sup> The second part of the E-grade designation (for example, 2.0-1/6) indicates fraction of cross section that can be occupied by edge characteristics which include knots, knot holes, burls, distorted grain, or decay partially or wholly at edges of wide faces.



7.3.4 The stress modification factor in compression parallel to grain for laminations in members of two or three laminations shall be the same as the strength ratio determined using Practice D 245 for a single piece of lumber of the applicable grade.

7.4 *Stress Modification Factor in Tension Parallel to the Grain:*

7.4.1 The stress modification factor for tension parallel to grain ( $SMF_t$ ) for each lamination shall be the lower of the two modification factors determined separately on the basis of knots and on the basis of slope of grain as follows:

7.4.2 *Knots*—The tension stress modification factor for knots ( $SMF_{t\ knots}$ ) shall be determined as follows:

$$SMF_{t\ knots} = 1 - Y_2 \quad (10)$$

where:

$SMF_{t\ knots}$  = tensile stress modification factor, and  
 $Y_2$  = maximum edge knot size permitted in the grade expressed in a decimal fraction of the dressed width of the wide face of the piece of lumber used for the lamination. Centerline knot size for visually graded laminations shall be limited to that resulting in an equivalent edgewise bending strength ratio as determined by Practice D 245.

7.4.3 *Slope of Grain*—The tension stress modification factor for each lamination shall be as given in Table 4.

7.5 *Modulus of Elasticity (E)*—When *LSE* is determined by test methods other than those described in 3.1.6.1, then modification factors described in section 4.3 of Practice D 2915 shall be applied.

7.6 *Horizontal Shear:*

7.6.1 *Horizontally Laminated Timbers*—The stress modification factor for horizontal shear for laminations in horizontally laminated timbers shall be calculated as the ratio of the wane-free width to total surfaced width. Thus, when wane up to 1/6 of the width is allowed along both edges, the stress modification factor shall be 2/3.

7.6.2 *Vertically Laminated Timbers*—For vertically laminated timbers composed of 3, 5, 7, or 9 laminations with unbonded edge joints, a modification factor of 0.4 shall be applied to each lamination. For all other vertically laminated timbers composed of laminations with unbonded edge joints, a modification factor of 0.5 shall be applied to each lamination.

7.7 *Compression Perpendicular to Grain and Radial Compression:*

7.7.1 A stress modification factor of 1.0 shall be applicable to all laminations.

7.8 *Radial Tension:*

7.8.1 A stress modification factor of 1.0 shall be applicable to all laminations.

## 8. Adjustment of Properties for End-Use Conditions

8.1 The allowable properties developed using Sections 6 and 7 are based on normal load duration, 12 % average moisture content conditions, and approximately 68°F (20°C) temperatures. Bending stress is for a 12-in. (0.3-m) deep straight beam, uniformly loaded with a 21:1 span-to-depth ratio. Design at other conditions requires modifications.

8.2 *Moisture Content*—Two different moisture conditions are recognized for structural glued laminated timber members: dry service and wet service. Dry service is the use condition where the moisture content of the wood is less than 16 %. Wet service is the use where wood attains moisture contents of 16 % or more. For wet service conditions, properties developed using Sections 6 and 7 shall be multiplied by the appropriate factors given in Table 8.

8.3 *Duration of Load*—Normal load duration contemplates fully stressing a member to its allowable value either continuously or cumulatively for ten years. For other durations of load, all properties except *E* and compression perpendicular to grain are permitted to be increased in accordance with Practice D 245. For longer durations of load, all properties except *E* and compression perpendicular to grain shall be decreased in accordance with Practice D 245.

8.4 *Flat Use Factor*—For bending members with the load applied parallel to the wide face of the laminations (vertically laminated members), the bending stress shall be adjusted for depths other than 12 in. (0.3 m) by multiplying by  $(12/d)^{1/9}$  where  $d$  is the beam depth, in inches, or  $(0.3/d)^{1/9}$  where  $d$  is the beam depth in meters.

8.5 *Volume Factor*—For bending members with the load applied perpendicular to the wide face of the laminations (horizontally laminated members), the bending stress shall be adjusted for sizes greater than the standard size beam (as defined below) by multiplying by the volume effect factor,  $C_V$ , defined as follows:

$$C_V = [5.125/w]^{1/x} [12/d]^{1/x} [21/L]^{1/x} \leq 1.0 \quad (11)$$

where:

$d$  = beam depth, in.,

$w$  = beam width, in.,

$L$  = length of beam between points of zero moment, ft, and

$x$  = determined by procedures outlined in Annex A8.

The standard beam is assumed to be uniformly loaded and is defined as having a depth of 12 in. (0.3 m), a width of 5 1/8 in. (0.13 m) and a length of 21 ft (6.4 m). For other than uniformly loaded members, adjustments for method of loading (Table 9) are necessary.

8.6 *Curvature*—For the curved portion of members, the allowable bending stress shall be reduced by the curvature factor,  $C_c = 1 - 2000(t/R)^2$  where  $t$  is the lamination thickness and  $R$  is the radius of curvature, both in similar units of measurement. Experience has shown that in order to minimize breakage problems during manufacture, the  $t/R$  ratio should not exceed 1/100 for hardwoods and southern pine and 1/125 for other softwood species.

8.7 *Treated Wood:*

**TABLE 8 Wet-Use Adjustment Factors**

Type of Stress	Wet-Use Factor
Bending	0.800
Compression parallel to the grain	0.730
Tension parallel to the grain	0.800
Modulus of elasticity	0.833
Horizontal shear	0.875
Compression perpendicular to the grain	0.530

**TABLE 9 Bending Stress Adjustment Factors for Loading Conditions**

Loading Conditions for Simply Supported Beams	Adjustment Factor
Single concentrated load	1.08
Uniform load	1.00
Third-point load	0.97

**TABLE 10 Adjustment Factors for Span-to-Depth Ratios**

Span-to-Depth Ratio	Adjustment Factor
7	1.06
14	1.02
21	1.00
28	0.98
35	0.97

8.7.1 Allowable properties associated with pressure preservative treated or fire-retardant treated members, whether the lumber is treated prior to gluing or the entire member is treated following gluing, shall take into account possible reductions due to high temperatures, pressure, or chemical effects associated with the treating process. When reductions are applicable they shall be based on tests of material subjected to the specific treatment conditions.

8.7.2 Members incised prior to preservative treatment may be subjected to a strength reduction depending on member size and the incision pattern and configuration. Such reductions shall be based on tests of the incised material.

8.8 *Temperature*—Reductions in some allowable properties are applicable when the member is exposed to abnormally high temperatures, especially for extended periods of time, or for exposure combining high temperatures and high moisture content. Increases to some allowable properties may be applicable for members used in continuous cold climatic conditions. See guidelines are given in Ref 9.

8.9 *Shear Deflection*—Member *E* values for bending combinations, calculated in accordance with Section 5, are applicable for a 21:1 span-to-depth ratio and assume that up to 5 % of the deflection will be due to shear and about 95 % due to bending when loaded uniformly. Such values may be applied to all loading conditions with span-to-depth ratios greater than 14:1 and the maximum deflection error due to shear will be of the order of 5 % or less. For more precise deflection calculations or for span-to-depth ratios less than 14:1, the effect of shear deflections should be considered separately.

## 9. Keywords

9.1 clear wood; glulam; lumber; structural glued laminated timber; timber

## ANNEXES

### (Mandatory Information)

#### A1. QUALIFICATION OF LAMINATIONS BY TEST

A1.1 If lumber is to be qualified by test as equivalent to visually graded or *E*-rated laminations, procedures in this section shall be followed. Tests shall include long span *E*, tensile strength, and specific gravity. Values for compression perpendicular to the grain and horizontal shear shall be determined following procedures previously described in this standard.

A1.1.1 Qualification shall be carried out on the size and grade of product for which qualification is desired, except that qualification at a specified width will satisfy qualification requirements for the next smallest width.

A1.1.1.1 If qualification of a width by test is used to qualify the next smaller width, selection criteria for the grade of both widths must be identical.

NOTE A1.1—As an example, qualification of a 2.0*E*, 1/6 edge knot grade in nominal 2 by 6 for a tension lamination target will qualify the same grade in 2 by 4 if the same *E* selection levels and edge knot selection criteria are used.

A1.1.1.2 Principles of Practice D 2915 shall be followed in sampling. A sample of 50 or more is required for *E* measurements; a minimum of 58 is required for tensile strength.

A1.2 Qualification by test shall include a flatwise bending modulus of elasticity on a 100:1 span-to-depth ratio (see 3.1.6.2).

A1.2.1 Qualification tests for *LSE* shall be carried out in accordance with Test Methods D 198 or D 4761.

A1.2.2 To qualify by *E* criterion, the average *LSE* (*E*) of the sample shall meet the following criteria:

$$(E) [1 + 0.237(COV)] \geq E_o \quad (A1.1)$$

where:

*COV* = coefficient of variation of *E* in the candidate stock, and

*E*<sub>o</sub> = average *LSE* of the target grade for which replacement is sought.

NOTE A1.2—For example, assume the target grade is 302-24 from *D*. Fir L with an *LSE* of  $2.1 \times 10^6$  psi. The candidate stock is *MSR* lumber. The *COV* of the qualification sample does not exceed 0.11 as given in the NDS (12). The product of *LSE* of the candidate sample and 1.026 must equal or exceed 2.1. As a second example, assume the target grade is 302-24 from Hem-Fir SSS with an *LSE* of  $1.8 \times 10^6$  psi. The candidate stock is visually graded; the National Design Specification for Wood Construction® (NDS®) *COV* for visually graded lumber is 0.25. The product of *LSE* of the candidate stock and 1.059 must equal or exceed 1.8.

A1.3 Qualification shall include a strength test of full-size laminations in tension.

A1.3.1 Tensile testing procedures shall follow the principles of Test Methods D 198 or D 4761 with a minimum gage length of 8 ft (2.4 m).