



Designation: G56 – 82 (Reapproved 2005)

## Standard Test Method for Abrasiveness of Ink-Impregnated Fabric Printer Ribbons<sup>1</sup>

This standard is issued under the fixed designation G56; the number immediately following the designation indicates the year of original adoption or, in the case of revision, the year of last revision. A number in parentheses indicates the year of last reapproval. A superscript epsilon ( $\epsilon$ ) indicates an editorial change since the last revision or reapproval.

### 1. Scope

1.1 This test method covers the determination of the abrasiveness of ink-impregnated fabric printer ribbons by means of a sliding wear test.

1.2 The values stated in inch-pound units are to be regarded as standard. The values given in parentheses are mathematical conversions to SI units that are provided for information only and are not considered standard.

1.3 *This standard does not purport to address all of the safety concerns, if any, associated with its use. It is the responsibility of the user of this standard to establish appropriate safety and health practices and determine the applicability of regulatory limitations prior to use.*

### 2. Referenced Documents

2.1 *ASTM Standards:*

G 40 Terminology Relating to Wear and Erosion

### 3. Terminology

3.1 *Definitions of Terms Specific to This Standard:*

3.1.1 *abrasive wear coefficient (for a ribbon)*—a measure of the ability of the ribbon to wear surfaces with which it comes in contact. The larger the value, the greater the ability to cause wear. The abrasive wear coefficient determined by this method is directly proportional to the volume of material removed from the steel sphere in the test.

3.2 For additional terms pertinent to this test method, see Terminology G 40.

### 4. Summary of Test Method

4.1 A ribbon specimen is wrapped around the cylindrical surface of a drum. A hardened steel sphere is pressed against the ribbon surface. While the drum rotates about its axis, the steel sphere is slowly moved in an axial direction across the surface of the ribbon (Note 1). After a specified amount of sliding has occurred, the test is stopped and the volume of material removed from the steel sphere is determined. This volume is then used to compute an abrasive wear coefficient for the ribbon specimen.

<sup>1</sup> This test method is under the jurisdiction of ASTM Committee G02 on Erosion and Wear, and is the direct responsibility of Subcommittee G02.30 on Wear.

Current edition approved Nov. 1, 2005. Published November 2005. Originally approved in 1977. Last previous edition approved in 2000 as G56 – 82 (2000)<sup>ε1</sup>. DOI: 10.1520/G0056-82R05.

NOTE 1—These two motions ensure that the unused ribbon is continually supplied to the contact area of the wear specimen; however, the contact region usually contains a mixture of unused and used ribbon surface.

### 5. Significance and Use<sup>2</sup>

5.1 This test method differentiates between ribbons on the basis of their ability to cause wear on surfaces with which they come in contact.

### 6. Apparatus<sup>3</sup>

6.1 *Ribbon Support Surface*—The overall shape of this member is that of a cylindrical drum  $48 \pm 1$  in. ( $1220 \pm 25$  mm) in diameter, concentric to within 0.0005 in. (0.013 mm) total run-out, and  $8.25 + 0.25 - 0$  in. ( $210 + 6 - 0$  mm) wide (see Fig. 1). The support surface is the cylindrical surface. This surface shall be rigid, made of metal (Note 2), and have a slot no greater than 0.020 in. (0.5 mm) in it so that the ends of the ribbon may be fed through into the interior. The interior shall contain a mechanism to uniformly provide tension to the ribbon specimen. This member shall be able to rotate about its axis and provide a linear velocity at the surface of the ribbon of  $321 \pm 6$  in./s ( $8150 \pm 150$  mm/s).

NOTE 2—2024 aluminum with a minimum thickness of 0.25 in. (6.35 mm) is adequate. The roughness of this surface should not exceed 20  $\mu$ m. (0.5  $\mu$ m), CLA.

6.2 *Wear Specimen Support*—This member shall be able to press a rigidly mounted 0.25-in. (6.35-mm) diameter spherical wear specimen against the ribbon surface and advance the specimen across the surface of the ribbon specimen in an axial direction at a rate of  $0.001 \pm 0.0001$  in. ( $0.254 \pm 0.025$  mm) per drum revolution (see Fig. 2). The mounting shall be of such a construction that continual contact with the ribbon surface is maintained with a normal load of 0.22 lb (this corresponds to the dead-weight load produced by a 100-g mass) between the wear specimen and ribbon surface and sufficiently rigid so that no rotation occurs.

<sup>2</sup> A discussion of the wear process and the influence of various parameters on the wear can be found in Bayer, R. G., "Wear by Paper and Ribbon" *Wear*, Vol 49, 1978, pp. 147–168 and Bayer, R. G., "Mechanism of Wear by Ribbon and Paper," *IBM Journal of Research and Development*, Vol 22, No. 6, November 1978, pp. 668–674

<sup>3</sup> An implementation of the apparatus required is discussed in "Testing Machine for the Evaluation of Wear by Paper," available from ASTM Headquarters as G02-1000.

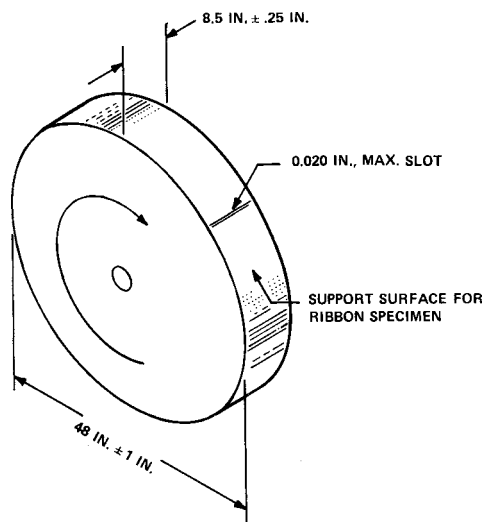

Metric Equivalents

in.	0.020	0.25	1	8.25	48
mm	0.51	6.35	25.4	210	1220

FIG. 1 Ribbon Support Surface

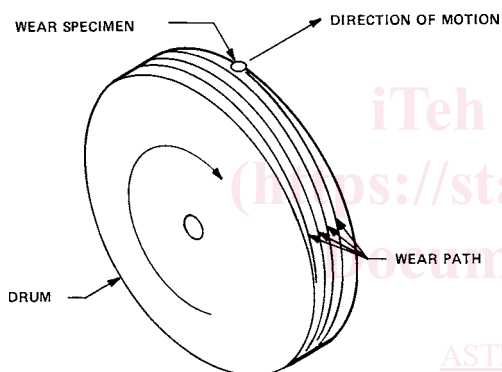

FIG. 2 Test Motion

## 7. Materials

7.1 *Wear Specimen*—The wear specimens are commercially available hardened steel balls. The balls shall be made of AISI 52100 steel with a characteristic hardness of 730 to 760 HV at 500 g and have a diameter of  $0.25 \pm 0.002$  in. ( $6.35 \pm 0.5$  mm). The surface roughness of the spheres shall be equal to or less than  $2 \mu\text{m}$ . ( $0.02 \mu\text{m}$ ) CLA.

7.2 *Ribbon Specimen*—The ribbon specimen(s) shall be of sufficient length so that the circumference of the drum can be completely covered and have enough length remaining so that the ends may be engaged by the internal tensioning device. This would require a specimen length in the range from 150 to 200 in. (4000 to 5000 mm). The preferred width of a specimen is 8 in (200 mm); however, narrower specimens may be utilized provided a sufficient number is available to achieve a total minimum sliding distance of  $5.8 \times 10^5$  in. ( $14.7 \times 10^6$  mm) without reuse of the same sample. This is approximately an effective total specimen width of 4 in. (100 mm).

## 8. Ambient Conditions

8.1 The relative humidity and temperature under which the test is conducted shall be monitored and recorded. The

mounted ribbon specimen shall be allowed to equilibrate for a minimum of 1 h at the relative humidity and temperature at which the test will be conducted.

## 9. Procedure

9.1 Put one end of the ribbon through the slot in the drum and fasten to the tension device. Then wrap the ribbon around the surface of the drum so that the outer surface of the ribbon is exposed. Feed the other end of the ribbon through the slot and fasten to the tension device. Apply sufficient tension so that the ribbon uniformly conforms to the surface of the drum and is held taut. Align the ribbon specimen so that the wear specimen does not contact or slide off the edges during the course of the test.

9.2 After the wear specimen is mounted to the wear specimen support, press the wear specimen against the surface of the ribbon with a load of 100 g. Contact should be made near but not with the edge of the ribbon. After the load has been applied, simultaneously start the axial motion of the specimen and the rotation of the drum.

9.3 For ribbon specimens of sufficient width, continue the sliding for a minimum of 30 min, or  $5.8 \times 10^5$  in. ( $14.7 \times 10^6$  mm) of sliding, without coming in contact with the edge of the ribbon specimen. Then remove the wear specimen from the surface while the drum is still rotating. Record the sliding duration.

9.4 For narrower specimens for which this cannot be done, remove the wear specimen from the ribbon surface prior to contacting the ribbon edge, while the drum is still rotating. Record the duration of sliding. Then stop the drum and press the wear specimen against a new ribbon specimen that has been mounted on the drum and continue the sliding. Repeat this process until the wear specimen has experienced a total duration of sliding of at least 30 min.

9.5 Total sliding duration should equal or exceed 30 min, with longer durations being preferred since they generate more wear. In general, the sliding duration should be selected so that a measurable wear scar results. Typical sliding durations are from 1 to 3 h.

9.6 After the wear specimen has accumulated the desired amount of sliding and has been removed from contact with the ribbon, clean it with a suitable solvent. Determine the volume of material removed from the wear specimen. Any technique for determining the volume may be used provided it has the capability of measuring volumes in the range of  $5 \times 10^{-8}$  in.<sup>3</sup> ( $10^{-6}$  cm<sup>3</sup>). A suggested method for determining the volume is described in [Appendix X1](#).

## 10. Calculations

10.1 The dimensionless abrasive wear coefficient for the ribbon,  $K$ , is obtained from the following equation:

$$K = 1.5 \times 10^4 \text{ s/in.}^3 \times \frac{V}{t}$$

where:

$V$  = volume of wear, in.<sup>3</sup>

$t$  = total duration of sliding, s

The higher the value of  $K$ , the more abrasive is the ribbon.