**Portable chain-saws — Chain brake
performance**

Scies à chaîne portatives — Performance du frein de chaîne

iTeh STANDARD PREVIEW
(standards.iteh.ai)

[ISO 6535:2008](https://standards.iteh.ai/catalog/standards/sist/18a22ef2-f78f-44e8-8400-c2ae478c30d2/iso-6535-2008)

<https://standards.iteh.ai/catalog/standards/sist/18a22ef2-f78f-44e8-8400-c2ae478c30d2/iso-6535-2008>



Reference number
ISO 6535:2008(E)

PDF disclaimer

This PDF file may contain embedded typefaces. In accordance with Adobe's licensing policy, this file may be printed or viewed but shall not be edited unless the typefaces which are embedded are licensed to and installed on the computer performing the editing. In downloading this file, parties accept therein the responsibility of not infringing Adobe's licensing policy. The ISO Central Secretariat accepts no liability in this area.

Adobe is a trademark of Adobe Systems Incorporated.

Details of the software products used to create this PDF file can be found in the General Info relative to the file; the PDF-creation parameters were optimized for printing. Every care has been taken to ensure that the file is suitable for use by ISO member bodies. In the unlikely event that a problem relating to it is found, please inform the Central Secretariat at the address given below.

iTeh STANDARD PREVIEW
(standards.iteh.ai)

ISO 6535:2008

<https://standards.iteh.ai/catalog/standards/sist/18a22ef2-f78f-44e8-8400-c2ae478c30d2/iso-6535-2008>



COPYRIGHT PROTECTED DOCUMENT

© ISO 2008

All rights reserved. Unless otherwise specified, no part of this publication may be reproduced or utilized in any form or by any means, electronic or mechanical, including photocopying and microfilm, without permission in writing from either ISO at the address below or ISO's member body in the country of the requester.

ISO copyright office
Case postale 56 • CH-1211 Geneva 20
Tel. + 41 22 749 01 11
Fax + 41 22 749 09 47
E-mail copyright@iso.org
Web www.iso.org

Published in Switzerland

Foreword

ISO (the International Organization for Standardization) is a worldwide federation of national standards bodies (ISO member bodies). The work of preparing International Standards is normally carried out through ISO technical committees. Each member body interested in a subject for which a technical committee has been established has the right to be represented on that committee. International organizations, governmental and non-governmental, in liaison with ISO, also take part in the work. ISO collaborates closely with the International Electrotechnical Commission (IEC) on all matters of electrotechnical standardization.

International Standards are drafted in accordance with the rules given in the ISO/IEC Directives, Part 2.

The main task of technical committees is to prepare International Standards. Draft International Standards adopted by the technical committees are circulated to the member bodies for voting. Publication as an International Standard requires approval by at least 75 % of the member bodies casting a vote.

Attention is drawn to the possibility that some of the elements of this document may be the subject of patent rights. ISO shall not be held responsible for identifying any or all such patent rights.

ISO 6535 was prepared by Technical Committee ISO/TC 23, *Tractors and machinery for agriculture and forestry*, Subcommittee SC 17, *Manually portable forest machinery*.

This third edition cancels and replaces the second edition (ISO 6535:1991), which has been technically revised. It also incorporates the Technical Corrigendum ISO 6535:1991/Cor.1:2004.

[ISO 6535:2008](https://standards.iteh.ai/catalog/standards/sist/18a22ef2-f78f-44e8-8400-c2ae478c30d2/iso-6535-2008)

<https://standards.iteh.ai/catalog/standards/sist/18a22ef2-f78f-44e8-8400-c2ae478c30d2/iso-6535-2008>

iTeh STANDARD PREVIEW
(standards.iteh.ai)

ISO 6535:2008

<https://standards.iteh.ai/catalog/standards/sist/18a22ef2-f78f-44e8-8400-c2ae478c30d2/iso-6535-2008>

Portable chain-saws — Chain brake performance

1 Scope

This International Standard specifies methods for measuring the braking time and release force of manually operated chain brakes on portable handheld chain-saws.

2 Normative references

The following referenced documents are indispensable for the application of this document. For dated references, only the edition cited applies. For undated references, the latest edition of the referenced document (including any amendments) applies.

ISO 6531, *Machinery for forestry — Portable chain-saws — Vocabulary*

3 Terms and definitions

For the purposes of this document, the terms and definitions given in ISO 6531 and the following apply.

3.1

braking time

interval from the instant the pendulum hits the guard to the instant the saw chain ceases to move

NOTE In order to avoid incorrect measurements due to vibration of the chain or the sprocket, it is considered that the chain has ceased to move when the time taken for two successive chain teeth to pass the measuring point exceeds 10 ms.

4 Test objects

The measurements shall be carried out on three different new production saws of the same model, equipped with guide bar and chain as recommended by the manufacturer.

5 Apparatus

- 5.1 **Rotational speed indicator**, with a rotating speed reading accuracy of $\pm 2,5$ %.
- 5.2 **Time recording device**, including pick-ups, having an accuracy of ± 5 ms.
- 5.3 **Pick-up device**, for registering the brake arm activation.
- 5.4 **Pick-up device**, for registering the chain motion.
- 5.5 **Force gauge**, having an accuracy of ± 1 N.

5.6 Pendulum, having a head with a flat strike face of $50 \text{ mm} \pm 1 \text{ mm}$ diameter and an arm with a length giving $700 \text{ mm} \pm 5 \text{ mm}$ distance between the swivel point and the centre of the head (see Figure 1). The arm shall be as light as possible. The pendulum shall cause an impact energy of $1,4 \text{ J} \pm 0,05 \text{ J}$ from a drop height (see Figure 1) of approximately 200 mm.

6 Chain-saw preparation

The engine shall have been run in and warmed up before the test and the carburettor and ignition adjusted according to the manufacturer's instructions.

The chain-saw and chain tension shall be adjusted for best cutting performance in accordance with the manufacturer's recommendations. If nothing else is stated, the chain tension shall be adjusted so that, when a 1 kg mass is hanging from the centre of the usable cutting length along the lower portion of the chain, the gap between the chain side link and the bar is a minimum of 0,017 mm per millimetre of bar length.

If applicable, the chain oil pump shall be adjusted to its maximum setting according to the manufacturer's recommendations. The type of chain lubrication oil used shall be noted in the test report.

7 Procedure

7.1 Braking time

7.1.1 General

Keep the throttle in a fixed position during the braking. This position shall correspond to the racing speed defined as the manufacturer's rated speed for maximum power plus 33 % or full throttle, whichever is the lesser. When the chain has stopped after braking, adjust the throttle to idling and reset the brake.

No brake adjustment of any kind and no cleaning shall be carried out during the test. No readings shall be excluded.

The saw shall be rigidly mounted by the handles during the test.

The brake shall be released with a blow from the pendulum (5.6), which shall strike the front hand-guard from a drop height causing an impact energy of $1,4 \text{ J} \pm 0,2 \text{ J}$ and along a line of action forming an angle of $45^\circ \pm 5^\circ$ with the axis of the guide-bar (see Figure 1).

Carry out the test according to 7.1.2, 7.1.3 and 7.1.4.

7.1.2 Preliminary running

7.1.2.1 Perform 300 actuations of the chain brake, without braking time measurements, at a chain speed between maximum power speed and racing speed and so that overheating is not expected. This shall be assured by the following precautions:

- the time interval between each of the 300 actuations shall be at least 30 s;
- the throttle trigger shall always be deactivated immediately after the brake has been actuated.

7.1.2.2 Cut softwood for the time it takes to use one tankful of fuel at approximately maximum power speed. The chain brake shall not be activated during this cutting. No cleaning of the chain saw is permitted after this cutting sequence.

7.1.3 First test

7.1.3.1 Run the engine at racing speed.

7.1.3.2 Brake the chain to a stop five times at 30 s intervals, and record the braking times. All tests in which the engine speed exceeds the racing speed shall be omitted and the test shall be repeated.

7.1.4 Second test

7.1.4.1 Run the engine at racing speed.

7.1.4.2 Carry out 15 activations of the brake at 30 s intervals, without braking time measurement.

7.1.4.3 Immediately carry out five brakes at 30 s intervals and record the braking times. All tests in which the engine speed exceeds the racing speed shall be omitted and repeated.

7.2 Release force (static test)

The engine shall not be run during this test. The force shall be applied at a uniform rate.

Measure the force on the front hand-guard needed to activate the brake in the direction of 45° forward and downward in relation to the guide bar centreline at the centre of the top (horizontal) part of the front hand-guard (see Figure 2). Repeat this measurement twice for a total of three measurements.

Each chain-saw shall be measured before and after the measurement of chain braking time (see 7.1) and the results of both series of measurements shall be reported.

ITEH STANDARD PREVIEW
(standards.iteh.ai)

8 Report

ISO 6535:2008

<https://standards.iteh.ai/catalog/standards/sist/18a22ef2-f78f-44e8-8400-c2ae478c30d2/iso-6535-2008>

8.1 Braking time

Report all recorded braking times and the calculated average value of the ten measurements (see 7.1.3.2 and 7.1.4.3) in milliseconds.

8.2 Release force

Report the six recorded release forces in newtons.

Dimensions in millimetres

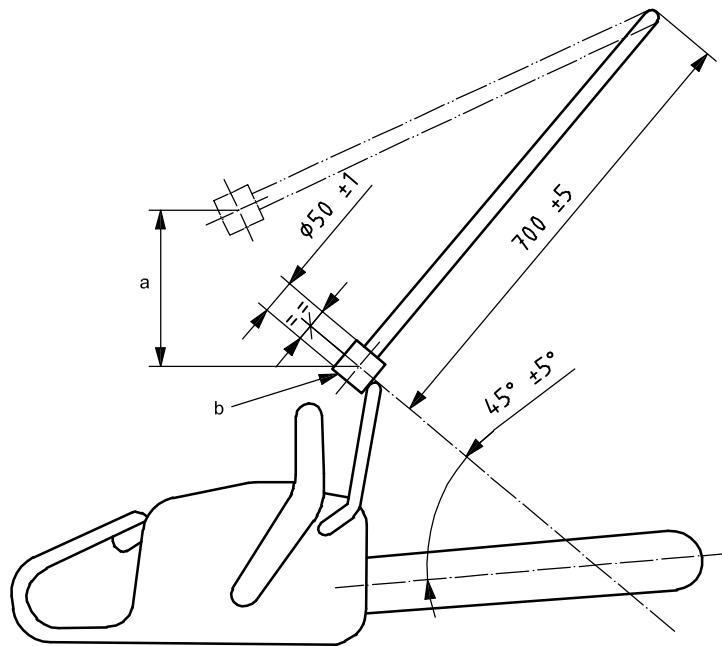

- a Pendulum drop height.
- b Sharp edges shall be chamfered.

Figure 1 — Impact direction and pendulum
 (standards.iteh.ai)

ISO 6535:2008
<https://standards.iteh.ai/catalog/standards/sist/18a22ef2-f78f-44e8-8400-c2ae478c30d2/iso-6535-2008>

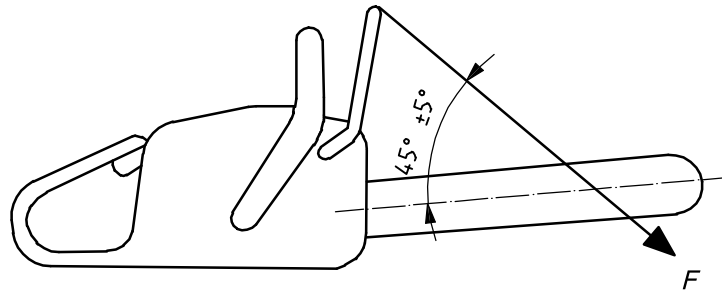

Figure 2 — Measuring direction for release force, *F*

iTeh STANDARD PREVIEW
(standards.iteh.ai)

ISO 6535:2008

<https://standards.iteh.ai/catalog/standards/sist/18a22ef2-f78f-44e8-8400-c2ae478c30d2/iso-6535-2008>