**Agricultural vehicles — Steering systems
for agricultural trailers — Interface for
articulated steering device of semi-
mounted trailers**

*Véhicules agricoles — Systèmes de direction pour remorques
agricoles — Interface pour dispositif de direction articulé pour
remorques semi-portées*

iTeh STANDARD PREVIEW
(standards.iteh.ai)

ISO 26402:2008

<https://standards.iteh.ai/catalog/standards/sist/fd756642-0a5e-4a45-9695-15fa144796b1/iso-26402-2008>



PDF disclaimer

This PDF file may contain embedded typefaces. In accordance with Adobe's licensing policy, this file may be printed or viewed but shall not be edited unless the typefaces which are embedded are licensed to and installed on the computer performing the editing. In downloading this file, parties accept therein the responsibility of not infringing Adobe's licensing policy. The ISO Central Secretariat accepts no liability in this area.

Adobe is a trademark of Adobe Systems Incorporated.

Details of the software products used to create this PDF file can be found in the General Info relative to the file; the PDF-creation parameters were optimized for printing. Every care has been taken to ensure that the file is suitable for use by ISO member bodies. In the unlikely event that a problem relating to it is found, please inform the Central Secretariat at the address given below.

iTeh STANDARD PREVIEW
(standards.iteh.ai)

ISO 26402:2008

<https://standards.iteh.ai/catalog/standards/sist/fd756642-0a5e-4a45-9695-15fa144796b1/iso-26402-2008>



COPYRIGHT PROTECTED DOCUMENT

© ISO 2008

All rights reserved. Unless otherwise specified, no part of this publication may be reproduced or utilized in any form or by any means, electronic or mechanical, including photocopying and microfilm, without permission in writing from either ISO at the address below or ISO's member body in the country of the requester.

ISO copyright office
Case postale 56 • CH-1211 Geneva 20
Tel. + 41 22 749 01 11
Fax + 41 22 749 09 47
E-mail copyright@iso.org
Web www.iso.org

Published in Switzerland

Foreword

ISO (the International Organization for Standardization) is a worldwide federation of national standards bodies (ISO member bodies). The work of preparing International Standards is normally carried out through ISO technical committees. Each member body interested in a subject for which a technical committee has been established has the right to be represented on that committee. International organizations, governmental and non-governmental, in liaison with ISO, also take part in the work. ISO collaborates closely with the International Electrotechnical Commission (IEC) on all matters of electrotechnical standardization.

International Standards are drafted in accordance with the rules given in the ISO/IEC Directives, Part 2.

The main task of technical committees is to prepare International Standards. Draft International Standards adopted by the technical committees are circulated to the member bodies for voting. Publication as an International Standard requires approval by at least 75 % of the member bodies casting a vote.

Attention is drawn to the possibility that some of the elements of this document may be the subject of patent rights. ISO shall not be held responsible for identifying any or all such patent rights.

ISO 26402 was prepared by Technical Committee ISO/TC 23, *Tractors and machinery for agriculture and forestry*, Subcommittee SC 4, *Tractors*.

iTeh STANDARD PREVIEW (standards.iteh.ai)

ISO 26402:2008

<https://standards.iteh.ai/catalog/standards/sist/fd756642-0a5e-4a45-9695-15fa144796b1/iso-26402-2008>

iTeh STANDARD PREVIEW
(standards.iteh.ai)

ISO 26402:2008

<https://standards.iteh.ai/catalog/standards/sist/fd756642-0a5e-4a45-9695-15fa144796b1/iso-26402-2008>

Agricultural vehicles — Steering systems for agricultural trailers — Interface for articulated steering device of semi-mounted trailers

1 Scope

This International Standard specifies the dimensions and clearance zones at the interface between tractor and trailer for articulated steering devices of semi-mounted trailers used in agriculture. It also specifies the maximum permissible forces at the connection of such articulated steering devices.

It is applicable exclusively in conjunction with ISO 24347, specifying a ball-type (mechanical) coupling device of 80 mm nominal diameter.

It is not applicable to the verification of the mechanical strength of the interface of the articulated steering device's interface, nor to the mechanical coupling device; this International Standard does not include technical requirements for the articulated steering device itself.

iTeh STANDARD PREVIEW

2 Normative references (standards.iteh.ai)

The following referenced documents are indispensable for the application of this document. For dated references, only the edition cited applies. For undated references, the latest edition of the referenced document (including any amendments) applies.

ISO 730:—¹, *Agricultural wheeled tractors — Rear-mounted three-point linkage — Categories 1N, 1, 2N, 2, 3N, 3, 4N and 4*

ISO 1103:2007, *Road vehicles — Coupling balls for caravans and light trailers — Dimensions*

ISO 17900:2002, *Agricultural trailers — Balanced and semi-mounted trailers — Determination of payload, vertical static load and axle load*

ISO 24347:2005, *Agricultural vehicles — Mechanical connections between towed and towing vehicles — Dimensions of ball-type coupling device (80 mm)*

3 Terms and definitions

For the purposes of this document, the terms and definitions given in ISO 17900 and the following apply.

3.1

articulated steering

equipment in which the steering forces are produced by a change in direction of the towing vehicle and the movement of the steered trailer wheels is firmly linked to the relative angle between the longitudinal axis of the towing vehicle and that of the trailer

1) To be published. (Replaces ISO 130-1:1994 and ISO 730-2:1979, and incorporates ISO 130-1:1994/Cor.1:1995)

4 General requirements

4.1 The interface of the articulated steering device may consist of one or two connecting points.

Figure 1 shows the version consisting of one connecting point as an example.

If only one connecting point is provided, it should be located on the left side in the direction of travel.

4.2 The dimensions of the connecting point(s) of the tractor (50 mm ball) shall be in accordance with ISO 1103; those of the connecting point(s) of the trailer shall be in accordance with Figure 2. An unintentional disconnection of the connecting point(s) of the tractor (50 mm ball) and the trailer shall be prevented by mechanical means at the connecting point(s) of the tractor (50 mm ball).

4.3 The maximum force in the direction of the steering rod according to Figure 1 shall not exceed 20 kN.

If necessary, appropriate means shall be used to limit this force to the stated value.

EXAMPLE Hydraulic power supply.

4.4 The centre line through an 80 mm ball-type coupling device according to ISO 24347 and the connecting point(s) of the tractor (50 mm ball) shall be parallel to the rear axle of the tractor. A tolerance of ± 5 mm both horizontally and vertically is permitted. The location in relation to the 80 mm ball-type coupling device shall be in accordance with Figure 3.

The geometry of the connecting point(s) of the tractor (50 mm ball) shall be according to ISO 1103.

4.5 Both the 80 mm ball-type coupling device and the connecting point(s) (50 mm ball) shall meet the requirements for angles of pitch, yaw and roll given in ISO 24347:2005, 3.1.4. If the angle of yaw of 60° prescribed for mechanical coupling devices cannot be obtained by the connecting point(s) (50 mm ball) without contact between tractor and drawbar parts, the maximum angle of yaw shall be limited by appropriate means (see Figure 1, item 4); appropriate parts of the trailer may act as such a limiter. The operator's manual for the trailer shall contain the necessary information.

4.6 The connecting point(s) of the tractor (50 mm ball) shall be detachable if they cause interference with the movement range of the lower links according to ISO 730 or the lateral movement limiting device(s). The operator's manual and/or mounting guidelines shall contain the necessary information.

5 Clearance zones

5.1 The clearance zone for the connecting point(s) shall be in accordance with Figure 4.

5.2 The combined clearance zone for the 80 mm ball-type coupling device and the connecting point(s) of the tractor (50 mm ball) shall be in accordance with Figure 5.

Dimensions in millimetres

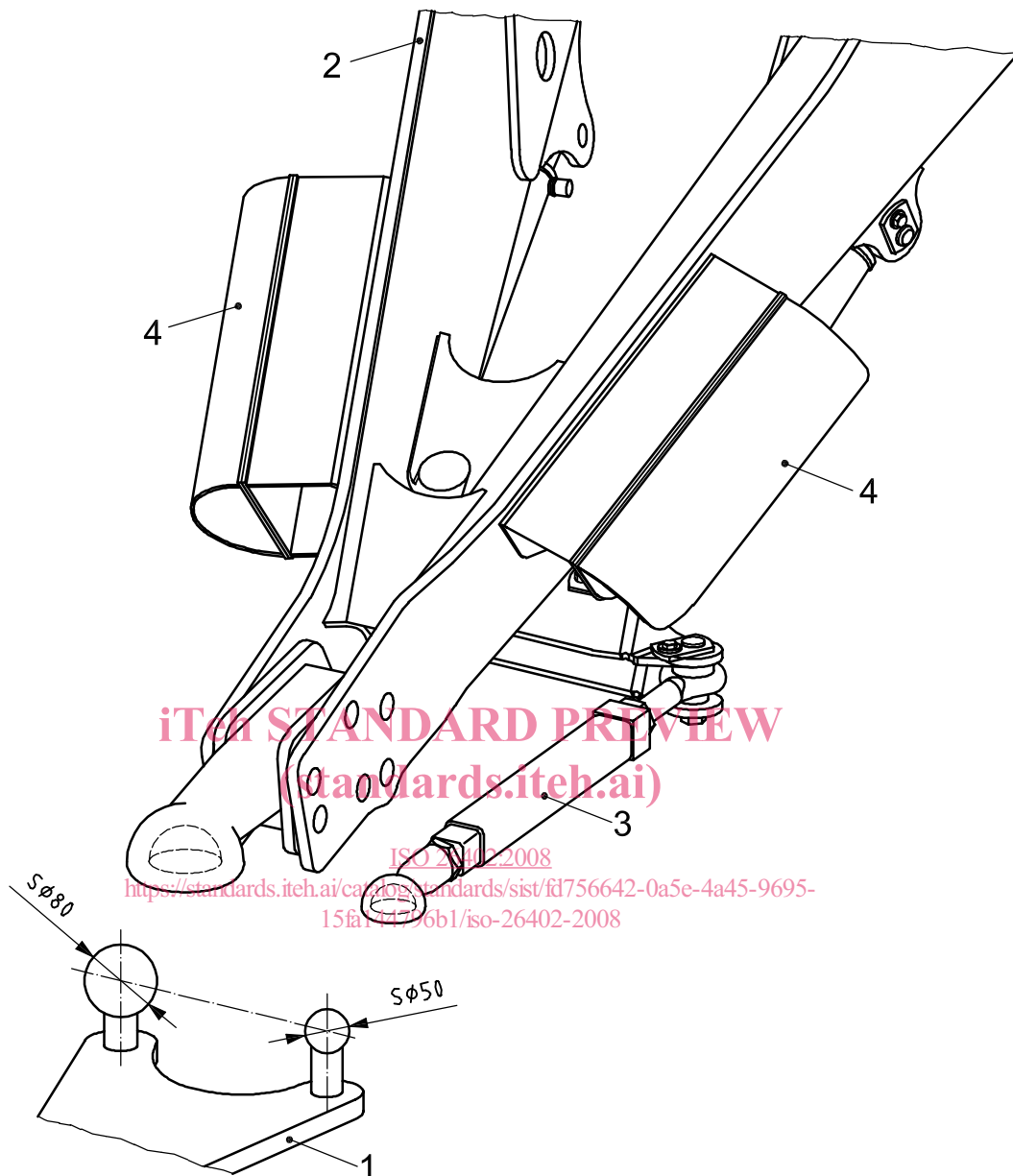
**Key**

- 1 connecting point of the tractor (50 mm ball)
- 2 trailer
- 3 steering rod of the articulated steering device
- 4 angle of yaw limiter

Where there is only one connecting point, it shall be on the left side in the direction of travel.

Figure 1 — Example of an articulated steering device with one connecting point

Dimensions in millimetres

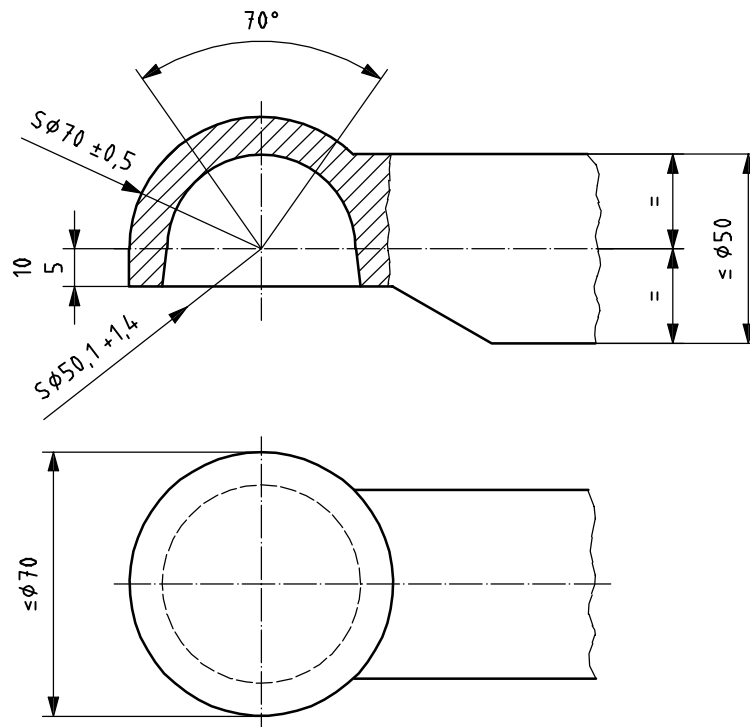

Figure 2 — Dimensions of connecting point(s) of trailer
(standards.itech.ai)

ISO 26402:2008
<https://standards.itech.ai/catalog/standards/sist/fd756642-0a5e-4a45-9695-15fa144796b1/iso-26402-2008>

Dimensions in millimetres

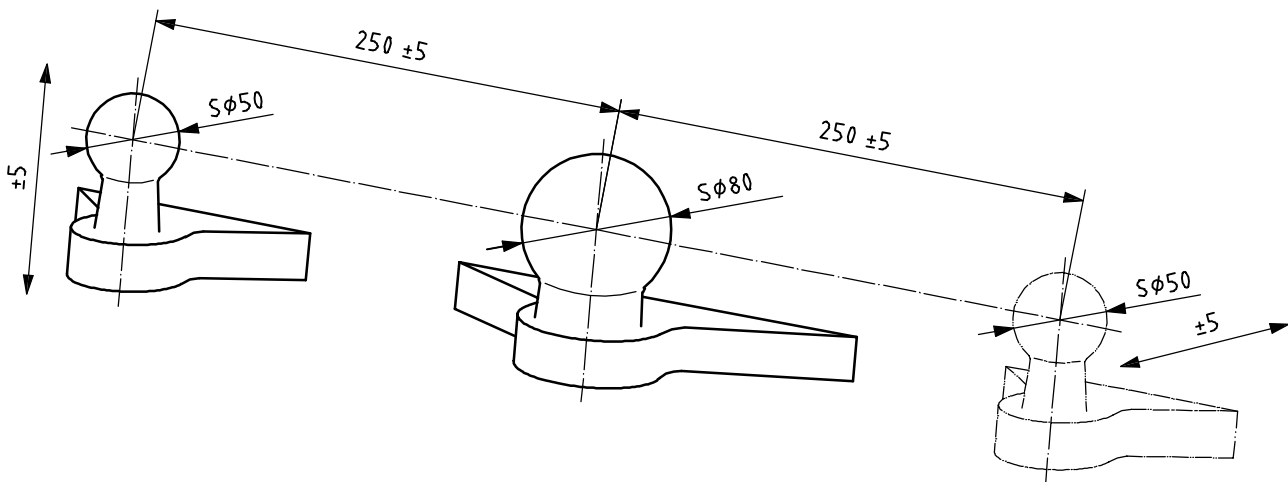

Figure 3 — Location of connecting point(s) of tractor (50 mm ball) in relation to 80 mm ball-type coupling device

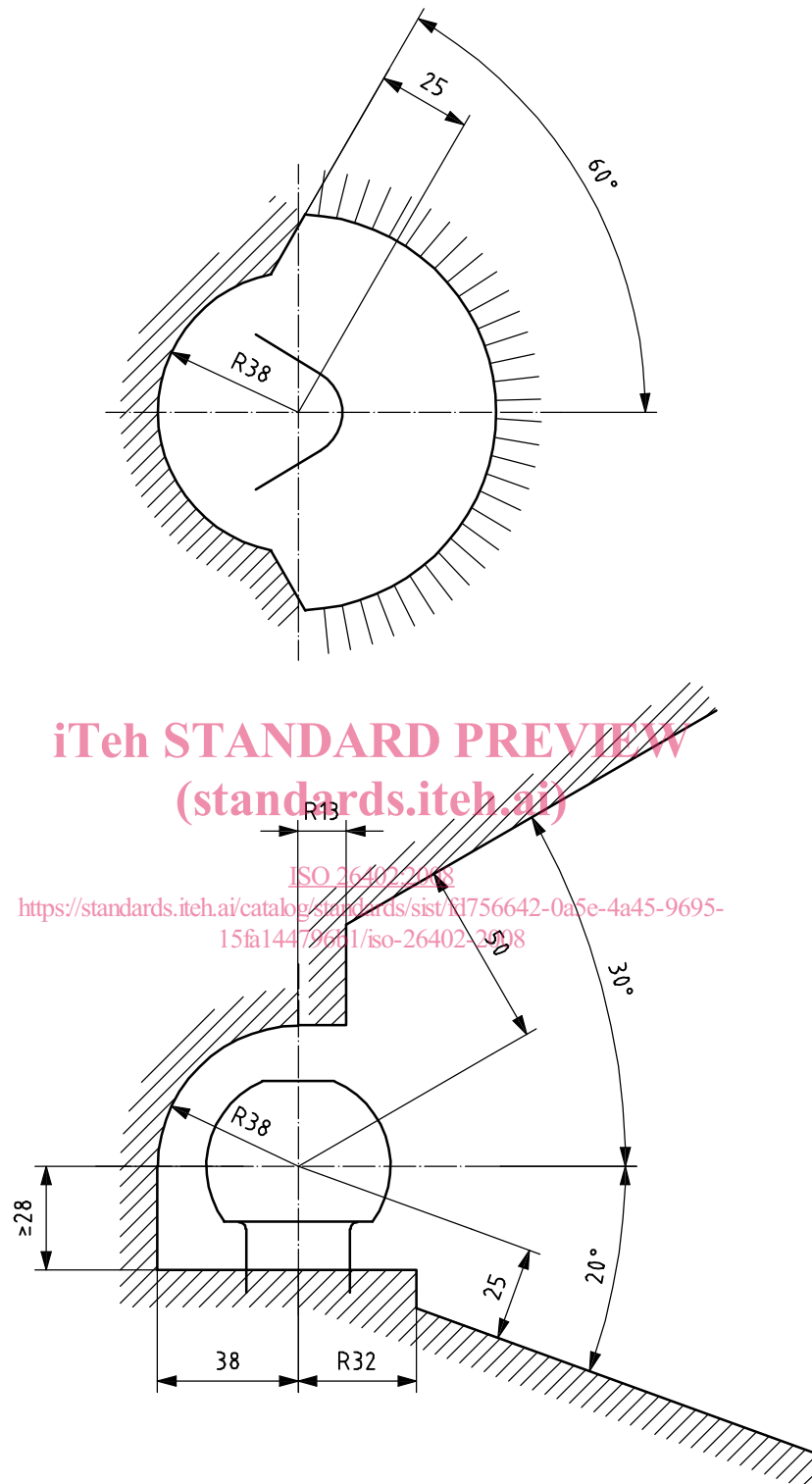

Figure 4 — Clearance zone for connecting point(s)