**Rubber, vulcanized — Determination of
creep in compression or shear**

*Caoutchouc vulcanisé — Détermination du fluage en compression ou
en cisaillement*

iTeh STANDARD PREVIEW
(standards.iteh.ai)

[ISO 8013:2006](https://standards.iteh.ai/catalog/standards/sist/64d72793-0a76-47cb-b248-32acb6060ca1/iso-8013-2006)

<https://standards.iteh.ai/catalog/standards/sist/64d72793-0a76-47cb-b248-32acb6060ca1/iso-8013-2006>



PDF disclaimer

This PDF file may contain embedded typefaces. In accordance with Adobe's licensing policy, this file may be printed or viewed but shall not be edited unless the typefaces which are embedded are licensed to and installed on the computer performing the editing. In downloading this file, parties accept therein the responsibility of not infringing Adobe's licensing policy. The ISO Central Secretariat accepts no liability in this area.

Adobe is a trademark of Adobe Systems Incorporated.

Details of the software products used to create this PDF file can be found in the General Info relative to the file; the PDF-creation parameters were optimized for printing. Every care has been taken to ensure that the file is suitable for use by ISO member bodies. In the unlikely event that a problem relating to it is found, please inform the Central Secretariat at the address given below.

iTeh STANDARD PREVIEW
(standards.iteh.ai)

ISO 8013:2006

<https://standards.iteh.ai/catalog/standards/sist/64d72793-0a76-47cb-b248-32acb6060ca1/iso-8013-2006>

© ISO 2006

All rights reserved. Unless otherwise specified, no part of this publication may be reproduced or utilized in any form or by any means, electronic or mechanical, including photocopying and microfilm, without permission in writing from either ISO at the address below or ISO's member body in the country of the requester.

ISO copyright office
Case postale 56 • CH-1211 Geneva 20
Tel. + 41 22 749 01 11
Fax + 41 22 749 09 47
E-mail copyright@iso.org
Web www.iso.org

Published in Switzerland

Contents

Page

Foreword.....	iv
Introduction	v
1 Scope	1
2 Normative references	1
3 Terms and definitions.....	1
4 Apparatus	2
5 Test piece	7
6 Time-lapse between vulcanization and testing	8
7 Mechanical conditioning.....	9
8 Test temperature.....	9
9 Procedure	9
10 Calculation of results	10
11 Expression of results	13
12 Test report.....	13
Annex A (informative) Values of forces required for rubbers of different hardnesses	14

ISO 8013:2006

<https://standards.iteh.ai/catalog/standards/sist/64d72793-0a76-47cb-b248-32acb6060ca1/iso-8013-2006>

Foreword

ISO (the International Organization for Standardization) is a worldwide federation of national standards bodies (ISO member bodies). The work of preparing International Standards is normally carried out through ISO technical committees. Each member body interested in a subject for which a technical committee has been established has the right to be represented on that committee. International organizations, governmental and non-governmental, in liaison with ISO, also take part in the work. ISO collaborates closely with the International Electrotechnical Commission (IEC) on all matters of electrotechnical standardization.

International Standards are drafted in accordance with the rules given in the ISO/IEC Directives, Part 2.

The main task of technical committees is to prepare International Standards. Draft International Standards adopted by the technical committees are circulated to the member bodies for voting. Publication as an International Standard requires approval by at least 75 % of the member bodies casting a vote.

Attention is drawn to the possibility that some of the elements of this document may be the subject of patent rights. ISO shall not be held responsible for identifying any or all such patent rights.

ISO 8013 was prepared by Technical Committee ISO/TC 45, *Rubber and rubber products*, Subcommittee SC 2, *Testing and analysis*.

This second edition cancels and replaces the first edition (ISO 8013:1988), which has been revised to update the normative references (ISO 471, ISO 3383, ISO 4648 and ISO 4661-1 have been replaced by ISO 23529 and ISO 1747 by ISO 1827).

ISO 8013:2006
<https://standards.iteh.ai/catalog/standards/sist/64d72793-0a76-47cb-b248-32acb6060ca1/iso-8013-2006>

Introduction

When a constant stress is applied to rubber, the deformation is not constant but increases gradually with time; this behaviour is called “creep”. Conversely, when rubber is subjected to a constant strain, a decrease in the stress in the material takes place; this behaviour is called “stress relaxation”.

The creep test is of particular interest where vulcanized rubbers are used to support a constant load, such as in bearings or mountings.

The processes responsible for creep may be physical or chemical in nature, and under all normal conditions both processes will occur simultaneously. However, at normal or low temperatures and/or short times, creep is dominated by physical processes, whilst at high temperatures and/or long times, chemical processes are dominant. In general, physical creep is found to be directly proportional to logarithmic time, and chemical creep to linear time; but great care must be taken in extrapolating time/creep curves in order to predict creep after periods considerably longer than those covered by the test, and in using tests at higher temperatures as accelerated tests to give information on creep at lower temperatures.

In addition to the need to specify the temperature- and time-intervals in a creep test, it is also necessary to specify the initial strain and the previous mechanical history of the test piece, since these may also influence the measured creep, particularly in rubbers containing filler.

iTeh STANDARD PREVIEW (standards.iteh.ai)

[ISO 8013:2006](https://standards.iteh.ai/catalog/standards/sist/64d72793-0a76-47cb-b248-32acb6060ca1/iso-8013-2006)

<https://standards.iteh.ai/catalog/standards/sist/64d72793-0a76-47cb-b248-32acb6060ca1/iso-8013-2006>

iTeh STANDARD PREVIEW
(standards.iteh.ai)

ISO 8013:2006

<https://standards.iteh.ai/catalog/standards/sist/64d72793-0a76-47cb-b248-32acb6060ca1/iso-8013-2006>

Rubber, vulcanized — Determination of creep in compression or shear

WARNING — Persons using this International Standard should be familiar with normal laboratory practice. This standard does not purport to address all of the safety problems, if any, associated with its use. It is the responsibility of the user to establish appropriate safety and health practices and to ensure compliance with any national regulatory conditions.

1 Scope

This International Standard specifies a method for the determination of creep in rubber continuously subjected to compressive or to shear forces. The standard cannot be used for intermittent deformation of rubber.

2 Normative references

The following referenced documents are indispensable for the application of this document. For dated references, only the edition cited applies. For undated references, the latest edition of the referenced document (including any amendments) applies.

ISO 815, *Rubber, vulcanized or thermoplastic — Determination of compression set at ambient, elevated or low temperatures* <https://standards.iteh.ai/catalog/standards/sist/64d72793-0a76-47cb-b248-32acb6060ca1/iso-8013-2006>

ISO 1827, *Rubber, vulcanized or thermoplastic — Determination of modulus in shear or adhesion to rigid plates — Quadruple shear method*

ISO 4664-1, *Rubber, vulcanized or thermoplastic — Determination of dynamic properties — Part 1: General guidance*

ISO 23529, *Rubber — General procedures for preparing and conditioning test pieces for physical test methods*

3 Terms and definitions

For the purposes of this document, the following terms and definitions apply.

3.1

creep increment

increase in strain which occurs in a specified time-interval under constant force and at constant temperature

NOTE It is expressed as the ratio of the increase in deformation over the time-interval to the initial, unstrained thickness.

3.2 creep index
relative increase in strain which occurs in a specified time-interval under constant force and at constant temperature

NOTE It is expressed as the ratio of the increase in the strain over the time-interval to the strain at the beginning of the interval.

3.3 compliance increment
ratio of the increase in strain which occurs in a specified time-interval under constant force and at constant temperature to the constant stress applied

4 Apparatus

4.1 Thickness-measuring device

Thickness measurements shall be made using a device complying with either ISO 23529 or the test apparatus described in 4.2. It shall be capable of measuring the test piece thickness to the nearest 0,1 mm. It shall have plates of diameter at least 30 mm. The dial gauge shall be fitted with a flat contact perpendicular to the plunger and parallel to the base plate and shall operate with a foot pressure of (22 ± 5) kPa.

4.2 Compression device for measurement in compression

The apparatus shall consist of two parallel, flat steel plates, between which the prepared test piece is compressed. In the case of unbonded test pieces, the plates shall be highly polished with a surface finished to not worse than 0,2 μm arithmetic mean deviation from the mean line of the profile. It is recommended that the operating surfaces of the plates be lubricated. The test pieces shall be free from mould lubricants and dusting powder. The plates shall be sufficiently rigid to withstand the force without bending and of sufficient size to ensure that the whole of the compressed test piece is within the area of the plates.

NOTE For most purposes, a silicone or fluorosilicone liquid having a kinematic viscosity of 0,01 m^2/s at standard temperature is a suitable lubricant.

One of the plates shall be rigidly mounted so that it does not move in any direction under the action of the compressive force. The other plate shall be able to move in a friction-free manner in one direction only, i.e. in a direction coincident with the axis of the test piece (see Figure 1).

The apparatus shall be capable of applying the full force with negligible overshoot and maintaining it constant to within 0,1 %. The mechanism for applying the force shall be such that the line of action of the applied force remains coincident with the axis of the test piece as it creeps.

Suitable equipment shall be connected to the compression device so that the deformation of the test piece may be determined, to an accuracy of $\pm 0,1$ % of the initial test piece thickness, at different times after the force has been fully applied.

Many types of apparatus have been used, with mechanical, electronic or optical measurement of deformation. Figure 2 shows a typical example using a micrometer dial gauge for the determination of creep in compression. The measuring device shall not exert a pressure of more than 22 kPa on the test piece at the beginning.

The test piece and the flat plates of the compression device shall be inside a temperature-controlled chamber (see 4.4).

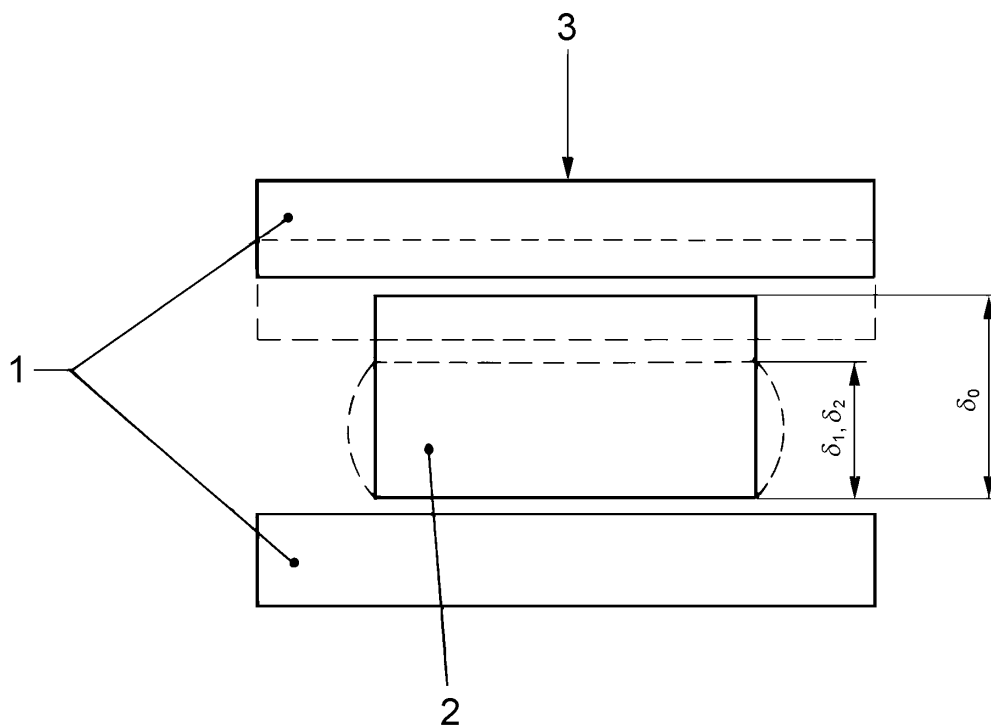
**Key**

- 1 steel plates
- 2 test piece
- 3 line of action of compressive force
- δ_0 initial thickness

iTeh STANDARD PREVIEW
(standards.iteh.ai)

[ISO 8013:2006](https://standards.iteh.ai/catalog/standards/sist/64d72793-0a76-47cb-b248-32acb6060ca1/iso-8013-2006)

<https://standards.iteh.ai/catalog/standards/sist/64d72793-0a76-47cb-b248-32acb6060ca1/iso-8013-2006>

Figure 1 — Test piece in compression

4.3 Shear device for measurements in shear

The apparatus shall be capable of measuring the shear deflection in the test piece due to the application of a constant shear force.

The apparatus shall be capable of applying the full force with negligible overshoot and maintaining it constant to within 0,1 %.

The force shall be applied either to the central metal plate, with the outer plates rigidly mounted, or to the outer metal plates with the central plate rigidly mounted. The line of action of the applied force shall be in the plane of the central plate, and pass through its centre in a direction perpendicular to the undeformed rubber test pieces. This line of action shall be maintained as the test piece creeps (see Figure 3).

The movement of the central plate relative to the outer plates shall be in a friction-free manner and only in the direction of the line of action of the applied force.

Suitable equipment shall be connected to the test piece so that relative movement of the central plate with respect to the outside plates can be determined with an accuracy of $\pm 0,01$ mm at different times after the force has been fully applied.

The test piece and the flat plates to which it is bonded shall inside a temperature-controlled chamber (see 4.4).

Figure 4 shows a typical shear test fixture.

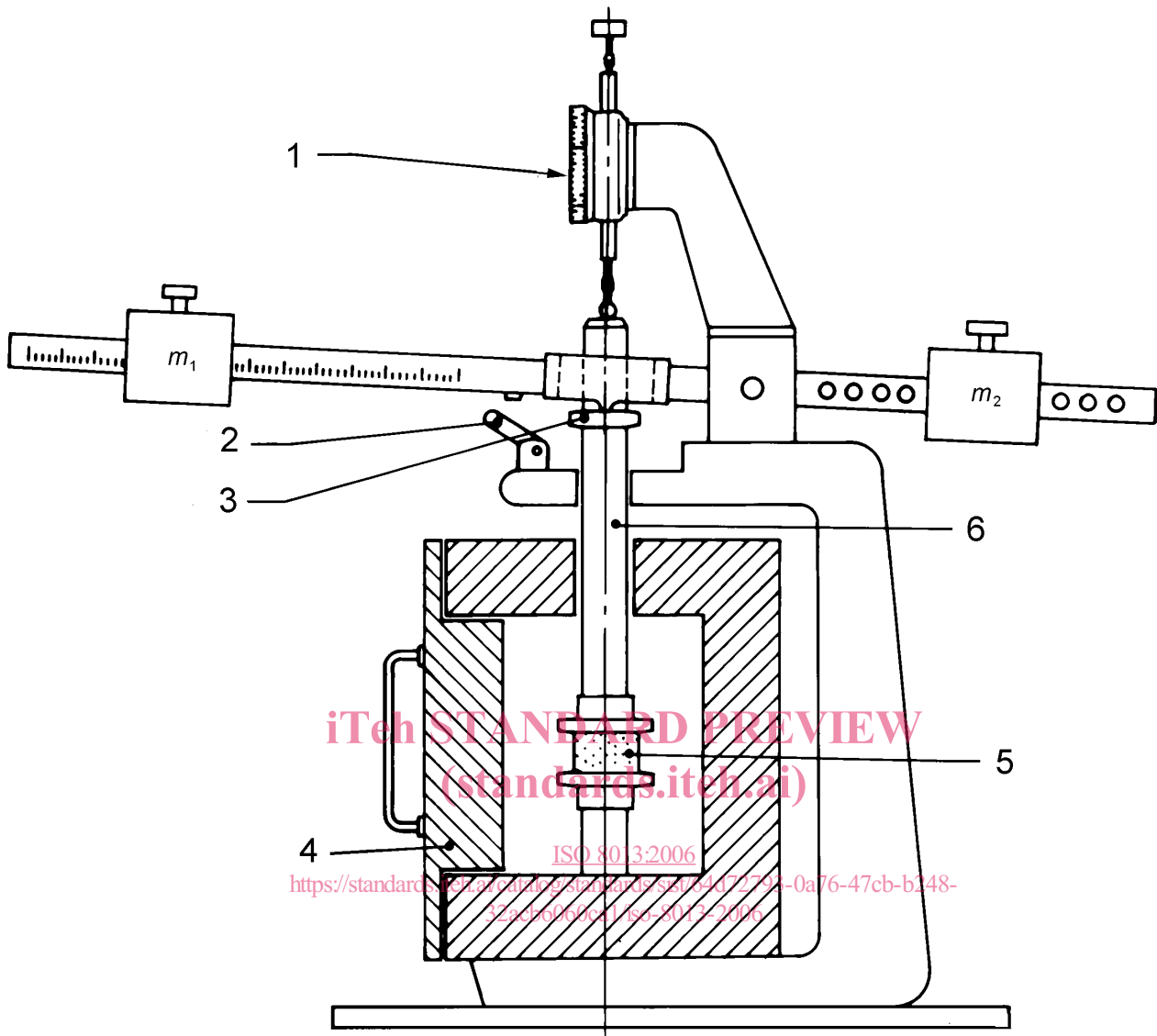

Key

- | | |
|-----------------|----------------------------------|
| 1 dial gauge | 4 temperature-controlled chamber |
| 2 locking lever | 5 test piece |
| 3 setting ring | 6 ceramic bar |

Figure 2 — Example of test arrangement for creep in compression with temperature-controlled chamber

4.4 Temperature-controlled chamber

A test chamber in accordance with ISO 23529, provided with temperature control to maintain the specified air temperature within the tolerances given in Clause 8, shall be used. Satisfactory circulation of the air shall be achieved by means of a fan. Care shall be taken to minimize change in temperature of the test piece by conduction through metal parts which are connected with the outside of the chamber or by direct radiation from heaters within the chamber.

4.5 Timer

Use a timer reading in seconds and minutes.

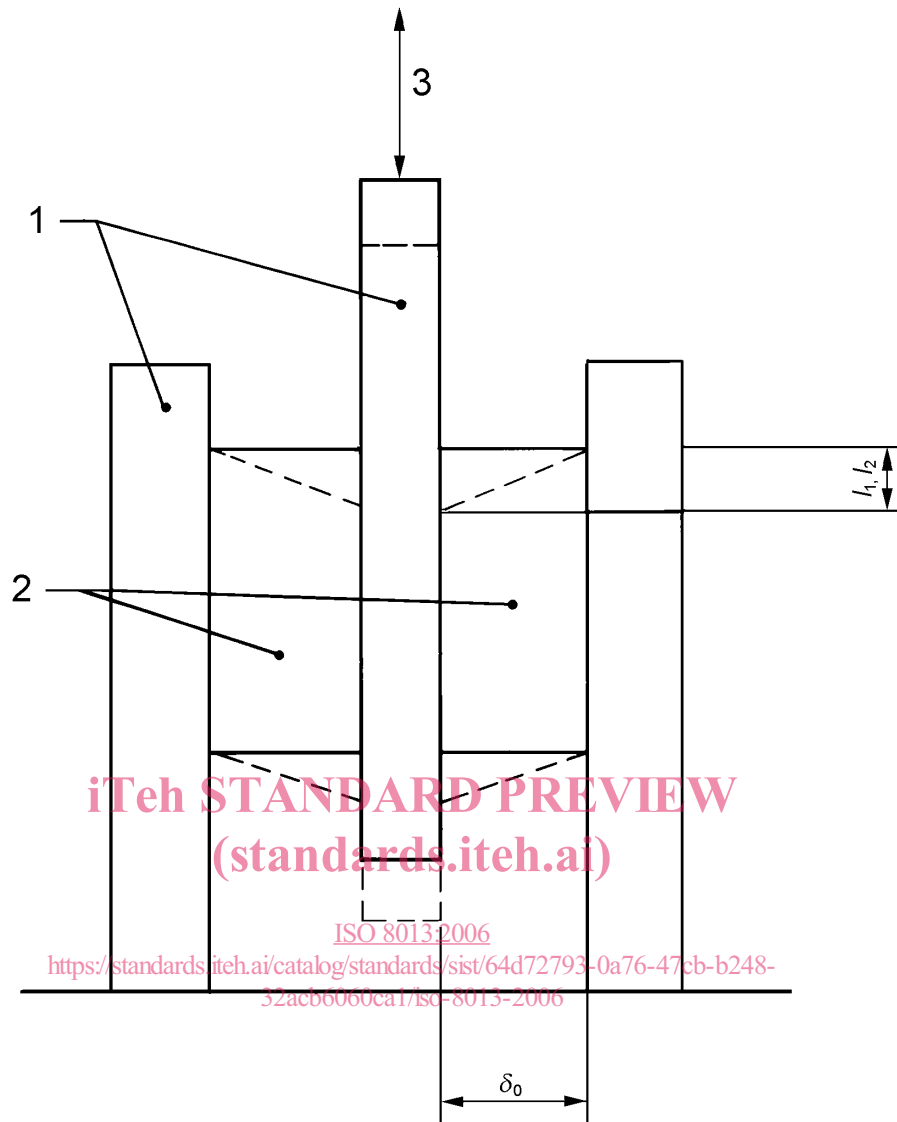
**Key**

- 1 steel plates
- 2 bonded test pieces
- 3 line of action of shear force
- δ_0 initial thickness

Figure 3 — Test piece in shear