**Rubber or plastics hoses and hose
assemblies — Hydraulic-pressure
impulse test without flexing**

*Tuyaux et flexibles en caoutchouc ou en plastique — Essai d'impulsions
de pression hydraulique sans flexion*

iTeh STANDARD PREVIEW
(standards.iteh.ai)

[ISO 6803:2008](https://standards.iteh.ai/catalog/standards/sist/75e83478-7ee3-4d08-9422-7a5ecc6e6afd/iso-6803-2008)

<https://standards.iteh.ai/catalog/standards/sist/75e83478-7ee3-4d08-9422-7a5ecc6e6afd/iso-6803-2008>



PDF disclaimer

This PDF file may contain embedded typefaces. In accordance with Adobe's licensing policy, this file may be printed or viewed but shall not be edited unless the typefaces which are embedded are licensed to and installed on the computer performing the editing. In downloading this file, parties accept therein the responsibility of not infringing Adobe's licensing policy. The ISO Central Secretariat accepts no liability in this area.

Adobe is a trademark of Adobe Systems Incorporated.

Details of the software products used to create this PDF file can be found in the General Info relative to the file; the PDF-creation parameters were optimized for printing. Every care has been taken to ensure that the file is suitable for use by ISO member bodies. In the unlikely event that a problem relating to it is found, please inform the Central Secretariat at the address given below.

iTeh STANDARD PREVIEW
(standards.iteh.ai)

ISO 6803:2008

<https://standards.iteh.ai/catalog/standards/sist/75e83478-7ee3-4d08-9422-7a5ecc6e6afd/iso-6803-2008>



COPYRIGHT PROTECTED DOCUMENT

© ISO 2008

All rights reserved. Unless otherwise specified, no part of this publication may be reproduced or utilized in any form or by any means, electronic or mechanical, including photocopying and microfilm, without permission in writing from either ISO at the address below or ISO's member body in the country of the requester.

ISO copyright office
Case postale 56 • CH-1211 Geneva 20
Tel. + 41 22 749 01 11
Fax + 41 22 749 09 47
E-mail copyright@iso.org
Web www.iso.org

Published in Switzerland

Contents

	Page
1 Scope	1
2 Normative references	1
3 Terms and definitions	1
4 Apparatus	1
5 Test fluid	1
6 Test temperature	2
7 Test pieces	2
8 Procedure	3
9 Expression of results	3
10 Test report	5

iTeh STANDARD PREVIEW (standards.iteh.ai)

[ISO 6803:2008](#)

<https://standards.iteh.ai/catalog/standards/sist/75e83478-7ee3-4d08-9422-7a5ecc6e6afd/iso-6803-2008>

Foreword

ISO (the International Organization for Standardization) is a worldwide federation of national standards bodies (ISO member bodies). The work of preparing International Standards is normally carried out through ISO technical committees. Each member body interested in a subject for which a technical committee has been established has the right to be represented on that committee. International organizations, governmental and non-governmental, in liaison with ISO, also take part in the work. ISO collaborates closely with the International Electrotechnical Commission (IEC) on all matters of electrotechnical standardization.

International Standards are drafted in accordance with the rules given in the ISO/IEC Directives, Part 2.

The main task of technical committees is to prepare International Standards. Draft International Standards adopted by the technical committees are circulated to the member bodies for voting. Publication as an International Standard requires approval by at least 75 % of the member bodies casting a vote.

Attention is drawn to the possibility that some of the elements of this document may be the subject of patent rights. ISO shall not be held responsible for identifying any or all such patent rights.

ISO 6803 was prepared by Technical Committee ISO/TC 45, *Rubber and rubber products*, Subcommittee SC 1, *Hoses (rubber and plastics)*.

This third edition cancels and replaces the second edition (ISO 6803:1994), which has been technically revised to include low-pressure impulse testing. The standard thus now covers high-pressure testing at pressures greater than 3 MPa and low-pressure testing at pressures from 1,5 MPa to 3 MPa.

[ISO 6803:2008](https://standards.iteh.ai/catalog/standards/sist/75e83478-7ee3-4d08-9422-7a5ecc6e6afd/iso-6803-2008)

<https://standards.iteh.ai/catalog/standards/sist/75e83478-7ee3-4d08-9422-7a5ecc6e6afd/iso-6803-2008>

Rubber or plastics hoses and hose assemblies — Hydraulic-pressure impulse test without flexing

1 Scope

This International Standard describes hose impulse testing, without flexing, of rubber or plastics hydraulic hose assemblies at both high and low impulse pressures. The high-pressure testing is carried out at pressures greater than 3 MPa and the low-pressure testing at pressures from 1,5 MPa to 3 MPa. The test procedure is applicable to hydraulic hose assemblies that are subject to pulsating pressures in service which are included in the product requirements.

NOTE Impulse test procedures with flexing can be found in ISO 6802, *Rubber and plastics hoses and hose assemblies with wire reinforcements — Hydraulic impulse test with flexing*.

2 Normative references

The following referenced documents are indispensable for the application of this document. For dated references, only the edition cited applies. For undated references, the latest edition of the referenced document (including any amendments) applies.

ISO 3448, *Industrial liquid lubricants — ISO viscosity classification*

[ISO 6803:2008](#)

ISO 8330, *Rubber and plastics hoses and hose assemblies — Vocabulary*

[7a5ecc6e6afd/iso-6803-2008](#)

ISO/TR 11340, *Rubber and rubber products — Hydraulic hose assemblies — External leakage classification for hydraulic systems*

3 Terms and definitions

For the purposes of this document, the terms and definitions given in ISO 8330 apply.

4 Apparatus

4.1 Pressure-application apparatus, capable of applying an internal pulsating pressure to the test piece at a rate of $1 \text{ Hz} \pm 0,25 \text{ Hz}$ using a hydraulic fluid circulating through the test hose, while the fluid is maintained at the required test temperature. Each pressure cycle shall be within the tolerances shown in Figure 2 (for high-pressure testing) or Figure 3 (for low-pressure testing). The nominal rate of pressure rise for high-pressure testing is given by Equation (1) in Figure 2. The rate of pressure rise for low-pressure testing shall be such that the pulse remains within the wave form envelope (see Figure 3).

4.2 Graphical recorder, digital-storage facility or oscilloscope, capable of measuring the pressure cycle to ensure that the wave form is within the envelope shown in Figure 2 or Figure 3. The recorder shall have a natural frequency of more than 250 Hz and shall be critically damped to give a response which is flat to within 5 % at up to 0,6 times the natural frequency.

5 Test fluid

Select a test fluid preferably with a kinematic viscosity from $32 \text{ mm}^2/\text{s}$ to $100 \text{ mm}^2/\text{s}$ at $40 \text{ }^\circ\text{C}$ (i.e. from grade ISO VG 32 to ISO VG 100 as specified in ISO 3448), and circulate it at a rate sufficient to maintain a uniform

fluid temperature within the test pieces. Other fluids may be used as agreed upon between the customer and the manufacturer.

6 Test temperature

The test temperature is normally specified in the referring hose standard. When the test temperature is not defined in the hose standard, the following temperatures are the preferred temperatures:

- 85 °C, 100 °C, 120 °C, 125 °C, 135 °C, 150 °C

The test fluid shall be circulated through the test pieces at the specified or chosen temperature with a tolerance of ± 3 °C. Cooling or heating of the test chamber shall not be permitted, except when referring standards require testing with synthetic-base test fluids at a temperature higher than 150 °C. When such higher temperatures are required, the test fluid need not be circulated, provided both the fluid and the test pieces are externally heated in the test chamber at the specified temperature with a tolerance of ± 5 °C.

7 Test pieces

7.1 Test pieces shall be complete hose assemblies with suitable end fittings attached. Unless otherwise specified, test four unaged hose assemblies with end fittings which have been attached for not more than 30 days. Where the referring standard requires, also test aged hose assemblies.

7.2 Calculate the necessary free length of the hose in the test piece as shown in Figure 1.

For values of d less than 25,4 mm, use $d = 25,4$ mm for the $+2d$ term in the expression for the hose free length, so that the hose between the fitting shell and the start of the bend radius is straight.

ISO 6803:2008

The actual free hose length shall agree with the calculated free hose length to within 0% or $+8$ mm, whichever is greater.

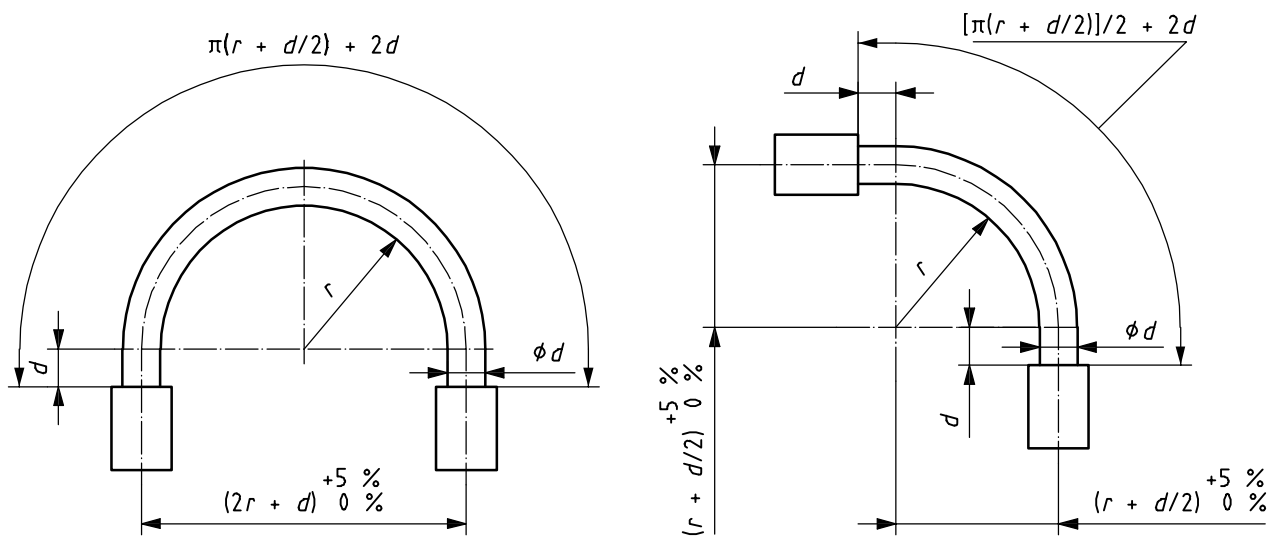

a) Hose sizes up to and including 22 mm nominal inside diameter

b) Hose sizes larger than 22 mm nominal inside diameter

- Key**
- r minimum bend radius
 - d hose outside diameter

Figure 1 — Test pieces for pressure impulse test

8 Procedure

8.1 Connect the test pieces to the apparatus. The test pieces shall be installed in accordance with Figure 1, i.e. test pieces of hose of nominal inside diameter up to and including 22 mm shall be bent through 180° and hoses of nominal inside diameter larger than 22 mm shall be bent through 90°.

8.2 Bring the test fluid to the test temperature and then apply a pulsating pressure internally to the hose assemblies at a uniform rate between 0,5 Hz and 1,3 Hz for the high-pressure test and between 0,2 Hz and 1,0 Hz for the low-pressure test. Record the pulse rate used. The pressure cycle shall fall within the shaded area of either Figure 2 or Figure 3, depending upon the test pressure. Continue the test for the specified number of cycles or until an assembly fails. If a test is stopped before completion of the minimum number of cycles and then restarted, leakage may occur at the hose/fitting junction upon restarting the test and until the test temperature is reached. Leakage less than class 4 as defined in ISO/TR 11340 does not constitute a failure of the hose assembly. Any leakage shall be reported in accordance with the classification in ISO/TR 11340.

Determine the duration required for the impulse test, in total number of cycles, from the referring standard. Where agreed samples are required, refer to the relevant hose or hose assembly standard.

It is recommended that the test fluid be changed frequently to prevent breakdown.

NOTE This is a destructive test. Assemblies which have been subjected to this test, should therefore be discarded.

9 Expression of results

Record the number of cycles to failure or, if failure did not occur, the number of cycles completed.

NOTE The test results obtained are only valid for the combination of hose, fitting type and fitting design that was actually tested.

[ISO 6803:2008](https://standards.iteh.ai/catalog/standards/sist/75e83478-7ee3-4d08-9422-7a5ecc6e6afd/iso-6803-2008)

<https://standards.iteh.ai/catalog/standards/sist/75e83478-7ee3-4d08-9422-7a5ecc6e6afd/iso-6803-2008>

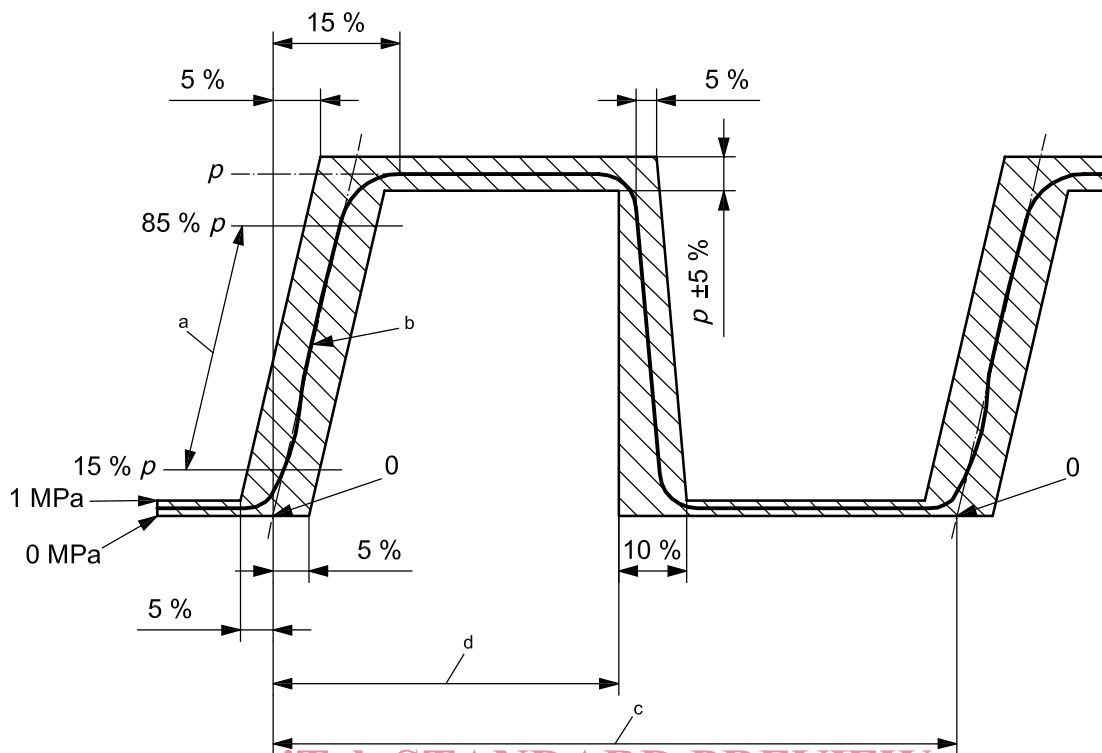

iTeh STANDARD PREVIEW
(standards.iteh.ai)

Key

p test pressure

a Rate of rise to be determined between these points.

[ISO 6803:2008](https://standards.iteh.ai/catalog/standards/sist/75e83478-7ee3-4d08-9422-7a5ecc6e6afd/iso-6803-2008)

b Secant pressure rise.

<https://standards.iteh.ai/catalog/standards/sist/75e83478-7ee3-4d08-9422-7a5ecc6e6afd/iso-6803-2008>

c One pulse cycle.

d 45 % to 55 % of the cycle.

The secant pressure rise is the straight line drawn through two points on the pressure rise curve, one point at 15 % of the test pressure and the other at 85 % of the test pressure.

Point 0 is the intersection of the secant pressure rise with 0 pressure.

The rate of pressure rise is the slope of the secant pressure rise, expressed in MPa/s.

The nominal rate of pressure rise shall be equal to that given by Equation (1):

$$R = f(10p - k) \tag{1}$$

where

R is the rate of pressure rise, in MPa/s;

f is the frequency, in Hz;

p is the nominal test pressure, in MPa;

k = 5 MPa.

The actual rate of pressure rise shall be determined as shown in the figure and shall be within a tolerance of ±10 % of the calculated nominal value.

Figure 2 — Pressure pulse wave form envelope for high-pressure test

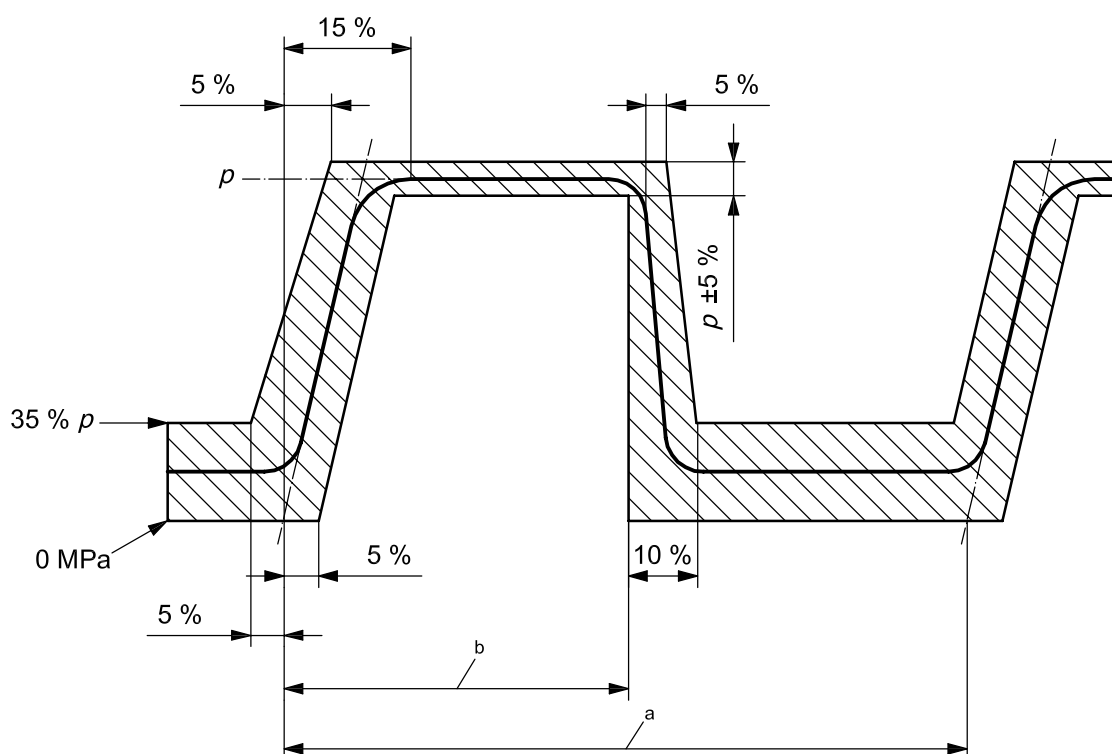

iTeh STANDARD PREVIEW
(standards.iteh.ai)

Key

p test pressure

a One pulse cycle.

b 45 % to 55 % of the pulse cycle.

ISO 6803:2008

7a5ecc6e6af1/iso-6803-2008

The pressure rise shall be contained within the wave form envelope shown in the figure.

Figure 3 — Pressure pulse wave form envelope for low-pressure test

10 Test report

The test report shall include the following information:

- a reference to this International Standard;
- a full description of the hose or hose assembly tested, including the fitting identification and attachment details, such as skive length and crimp diameter;
- the test temperature;
- the test pressure;
- the test fluid;
- the rate of pressure rise;
- the pulse cycle rate;
- whether the test pieces were bent through 90° or through 180° ;
- the number of cycles to failure, or the number of cycles completed, for each test piece;
- the position and mode of failure of each test piece, or the condition of each test piece on completion of the test;
- the date of the test.