



Designation: D6184 – 98(Reapproved 2005)

Standard Test Method for Oil Separation from Lubricating Grease (Conical Sieve Method)¹

This standard is issued under the fixed designation D6184; the number immediately following the designation indicates the year of original adoption or, in the case of revision, the year of last revision. A number in parentheses indicates the year of last reapproval. A superscript epsilon (ϵ) indicates an editorial change since the last revision or reapproval.

This standard has been approved for use by agencies of the Department of Defense.

INTRODUCTION

The conical sieve method for measuring leakage from lubricating grease (commonly known as the cone bleed test) is virtually the same as Federal Test Method (FTM) 791C Method 321.3, Oil Separation from Lubricating Grease (Static Technique). Despite the lack of a precision statement, Method 321.3 has been used for many years in military and industrial grease specifications to determine fluid separation tendencies. Test Method D6184 overcomes the deficiencies of Method 321.3. It reflects the procedures and precision determinations used in a cooperative study in Subcommittee D02.G0 of Committee D02 and is intended to supersede the FTM method.

1. Scope

1.1 This test method covers the determination of the tendency of lubricating grease to separate oil at an elevated temperature. This test method shall be conducted at 100°C for 30 h unless other conditions are required by the grease specification.

1.2 This test method is not suitable for greases having a penetration (Test Methods **D217**) greater than 340 (softer than NLGI No. 1 grade).

1.3 The values stated in SI units are to be regarded as standard. No other units of measurement are included in this standard.

1.4 *This standard does not purport to address all the safety concerns, if any, associated with its use. It is the responsibility of the user of this standard to establish appropriate safety practices and determine the applicability of regulatory limitations prior to use.*

2. Referenced Documents

2.1 ASTM Standards:²

¹ This test method is under the jurisdiction of ASTM Committee **D02** on Petroleum Products and Lubricants and is the direct responsibility of Subcommittee **D02.G0.03** on Physical Tests

Current edition approved Nov. 1, 2005. Published November 2005. Originally approved in 1997. Last previous edition approved in 1998 as D6184 – 98. DOI: 10.1520/D6184-98R05.

² For referenced ASTM standards, visit the ASTM website, www.astm.org, or contact ASTM Customer Service at service@astm.org. For *Annual Book of ASTM Standards* volume information, refer to the standard's Document Summary page on the ASTM website.

D217 Test Methods for Cone Penetration of Lubricating Grease

D1742 Test Method for Oil Separation from Lubricating Grease During Storage

E437 Specification for Industrial Wire Cloth and Screens (Square Opening Series) (Discontinued 2000) Replaced by **E 2016** (Withdrawn 2000)³

2.2 *Government Standard:*

Federal Test Method (FTM) 791C Method 321.3, Oil Separation from Lubricating Greases (Static Method)⁴

3. Terminology

3.1 Definitions:

3.1.1 *lubricating grease, n*—a semifluid to solid product of a dispersion of a thickener in a liquid lubricant.

3.1.1.1 *Discussion*—The dispersion of the thickener forms a two-phase system and immobilizes the liquid lubricant by surface tension and other physical forces. Other ingredients imparting special properties are often included. **D217**

3.1.2 *oil separation, n*—the appearance of a liquid fraction from an otherwise homogeneous lubricating composition. **D1742**

3.1.3 *thickener, n*—in a lubricating grease, a substance composed of finely divided particles dispersed in a liquid lubricant to form the product's structure.

³ The last approved version of this historical standard is referenced on www.astm.org.

⁴ Available from Standardization Documents Order Desk, Bldg. 4 Section D, 700 Robbins Ave., Philadelphia, PA 19111-5094, Attn: NPODS.

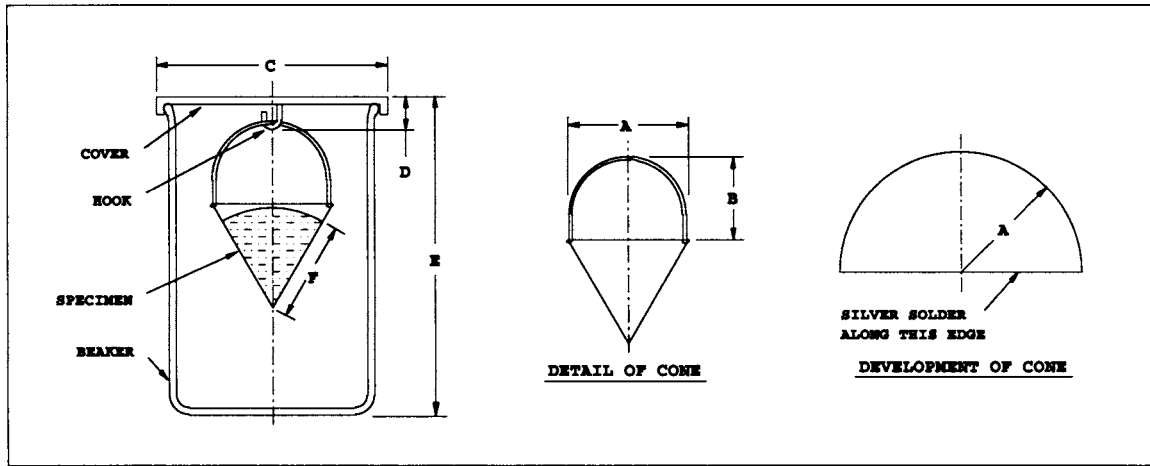

NOTE 1—Dimensions are provided in millimetres (with in./lb. units in parentheses) as follows:

A	38.1 ± 0.3	(1.50 ± 0.01)	radius
B	27.0 ± 0.3	(1.06 ± 0.01)	height
C	70	(2.8)	approximately (to fit beaker)
D	9.7 ± 3.3	(0.38 ± 0.13)	length
E	100	(4)	approximately
F	36	(1.4)	approximately

FIG. 1 Cone Fabrication and Test Setup

3.1.3.1 Discussion—The thickener can be fibers (such as various metallic soaps) or plates or spheres (such as certain non-soap thickeners) which are insoluble or, at most, only very slightly soluble in the liquid lubricant. The general requirements are that the solid particles be extremely small, uniformly dispersed, and capable of forming a relatively stable, gel-like structure with the liquid lubricant

D217

4. Summary of Test Method

4.1 The weighed sample is placed in a cone-shaped, wire-cloth sieve, suspended in a beaker, then heated under static conditions for the specified time and temperature. Unless otherwise required by the grease specification, the sample is tested at standard conditions of $100 \pm 0.5^\circ\text{C}$ for 30 ± 0.25 h. The separated oil is weighed and reported as a percentage of the mass of the starting test sample.

5. Significance and Use

5.1 When a lubricating grease separates oil, the residual material changes in consistency, which can affect the ability of the product to function as designed. Test results obtained with this procedure are intended to correlate with oil separation that occurs in 35-lb pails of grease during storage. They are not intended to predict oil separation tendencies of grease under dynamic service conditions.

NOTE 1—No quantitative relationship between results and oil separation in 35-lb pails has been developed.

5.2 This test method is used for specifications and quality control.

NOTE 2—No data have been developed to compare results between this test method and Test Method D1742.

6. Apparatus

6.1 Test Apparatus—The assembled apparatus consists of a cone-shaped sieve constructed of 60-mesh, corrosion-resistant wire cloth, a 200-mL tall-form beaker without spout, and a closely fitting cover with a hook in the center. Construction details and dimensions are shown in Fig. 1.

6.1.1 The conical sieve shall be fabricated of stainless steel, monel, or nickel wire cloth, of No. 60 medium-heavy mesh as defined in Table 2 of Specification E437 and shall be fabricated to the dimensions and requirements shown in Fig. 1.

NOTE 3—Sieves of stapled or wire-bound construction, instead of silver-soldered construction, have been used in the past. Such sieves do not conform to this test method.

6.2 Oven, capable of maintaining the specified temperature, $100 \pm 0.5^\circ\text{C}$.

6.3 Balance, having a minimum capacity of 250 g and a sensitivity of at least 0.01 g.

7. Sampling

7.1 Examine the sample for any indication of non-homogeneity such as oil separation, phase changes, or gross contamination. If any abnormal conditions are found, obtain a new sample.

7.2 The sample submitted for analysis should be minimally sufficient for duplicate testing.

7.3 Although the mass of the test grease is determined, the sieve is filled by volume rather than mass. Each test will require a quantity sufficient to fill the sieve to approximately the same level as indicated in Fig. 1 (about 10 mL). Approximately the same volume shall be used for each test regardless of the grease density; the mass will range from about 8 to 12 g.