



Designation: D 721 – 05

An American National Standard



Designation: 158/69(85)

Standard Test Method for Oil Content of Petroleum Waxes¹

This standard is issued under the fixed designation D 721; the number immediately following the designation indicates the year of original adoption or, in the case of revision, the year of last revision. A number in parentheses indicates the year of last reapproval. A superscript epsilon (ϵ) indicates an editorial change since the last revision or reapproval.

This standard has been approved for use by agencies of the Department of Defense.

1. Scope*

1.1 This test method covers the determination of oil in petroleum waxes having a congealing point of 30°C (86°F) or higher as determined in accordance with Test Method D 938, and containing not more than 15 % of oil.²

1.2 The values stated in inch-pound units are to be regarded as the standard. The values in parentheses are for information only.

NOTE 1—With some types of waxes, of oil contents greater than 5%, there may be an incompatibility with MEK resulting in the formation of two liquid phases. If this occurs, the method is not applicable to the material under test.

1.3 *This standard does not purport to address all of the safety concerns, if any, associated with its use. It is the responsibility of the user of this standard to establish appropriate safety and health practices and determine the applicability of regulatory limitations prior to use.*

2. Referenced Documents

- 2.1 *ASTM Standards:*³
- D 938 Test Method for Congealing Point of Petroleum Waxes, Including Petrolatum
 - E 1 Specification for ASTM Liquid-in-Glass Thermometers
 - E 128 Test Method for Maximum Pore Diameter and Permeability of Rigid Porous Filters for Laboratory Use

¹ This test method is under the jurisdiction of ASTM Committee D02 on Petroleum Products and Lubricants and is the direct responsibility of Subcommittee D02.10 on Properties of Petroleum Wax.

Current edition approved Nov. 1, 2005. Published November 2005. Originally approved in 1943. Last previous edition approved in 2004 as D 721-04.

In the IP, this test method is under the jurisdiction of the Standardization Committee. This test method was issued as a joint ASTM-IP tentative in 1964.

This test method was prepared jointly by the Technical Association of Pulp and Paper Industry and ASTM International.

This test method has been adopted for use by government agencies to replace Method 5431 of Federal Test Method Standard No. 791b.

² This test method is being used by some laboratories for products of higher oil content.

³ For referenced ASTM standards, visit the ASTM website, www.astm.org, or contact ASTM Customer Service at service@astm.org. For *Annual Book of ASTM Standards* volume information, refer to the standard's Document Summary page on the ASTM website.

2.2 Energy Institute Standards:

Specification for IP Standard Thermometers⁴

3. Summary of Test Method

3.1 The sample is dissolved in methyl ethyl ketone, the solution cooled to -32°C (-25°F) to precipitate the wax, and filtered. The oil content of the filtrate is determined by evaporating the methyl ethyl ketone and weighing the residue.

4. Significance and Use

4.1 The oil content of a wax may have significant effects on several of its properties, such as strength, hardness, flexibility, scuff resistance, coefficient of friction, coefficient of expansion, melting point, and oil straining. The importance of these effects may be dependent upon the ultimate use of the wax.

5. Apparatus

5.1 *Filter Stick and Assembly*, consisting of a 10-mm diameter sintered glass filter stick of 10 to 15 μ m maximum pore diameter as determined by the method in Appendix X1, provided with an air pressure inlet tube and delivery nozzle. It is provided with a ground-glass joint to fit a 25 by 170-mm test tube. The dimensions for a suitable filtration assembly are shown in Fig. 1.

NOTE 2—A metallic filter stick may be employed if desired. A filter stick made of stainless steel and having a 12.7-mm (1/2-in.) disk of 10 to 15- μ m maximum pore diameter, as determined by Test Method E 128, has been found to be satisfactory.⁵ The metallic apparatus is inserted into a 25 by 150-mm test tube and held in place by means of a cork.

5.2 *Cooling Bath*, consisting of an insulated box with 30 \pm 5-mm (1.2 \pm 0.2-in.) holes in the center to accommodate any desired number of test tubes. The bath may be filled with a

⁴ Available from Energy Institute, 61 New Cavendish St., London, WIG 7AR, U.K.

⁵ The sole source of supply of a suitable metal filter stick with designated porosity G known to the committee at this time is the Pall Trinity Micro Corp., Route 281, Cortland, NY 13045. A list of United Kingdom suppliers can be obtained from Energy Institute, 61 New Cavendish St., London, WIG 7AR, United Kingdom. If you are aware of alternative suppliers, please provide this information to ASTM International Headquarters. Your comments will receive careful consideration at a meeting of the responsible technical committee,¹ which you may attend.

*A Summary of Changes section appears at the end of this standard.

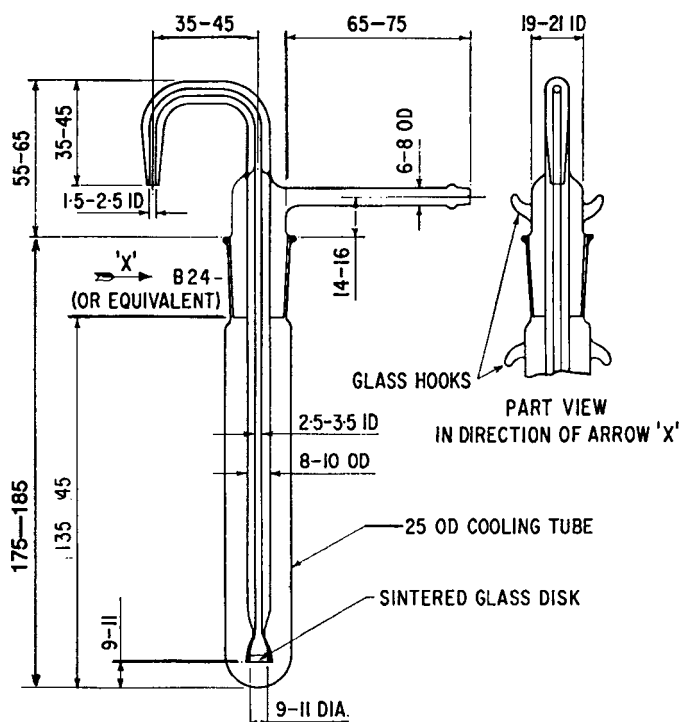

All dimensions are in millimetres

FIG. 1 Filter Stick

suitable medium such as kerosine, and may be cooled by circulating a refrigerant through coils, or by using solid carbon dioxide. A suitable cooling bath to accommodate three test tubes is shown in Fig. 2.

5.3 *Pipet*, or equivalent dispensing device capable of delivering 1 ± 0.05 g of molten wax.

5.4 *Transfer Pipet*, or equivalent volume dispensing device, capable of delivering 15 ± 0.06 mL.

5.5 *Air Pressure Regulator*, designed to supply air to the filtration assembly (8.5) at the volume and pressure required to give an even flow of filtrate. Either the conventional pressure-reducing valve or a mercury bubbler-type regulator has been found satisfactory. The latter type, illustrated in Fig. 3, consists of a 250-mL glass cylinder and a T-tube held in the cylinder by means of a rubber stopper grooved at the sides to permit the escape of excess air. The volume and pressure of the air supplied to the filtration assembly is regulated by the depth to which the T-tube is immersed in mercury at the bottom of the cylinder. Absorbent cotton placed in the space above the mercury prevents the loss of mercury by spattering. The air pressure regulatory is connected to the filter stick and assembly by means of rubber tubing.

5.6 *Temperature Measuring Device*:

5.6.1 *Thermometer*, having a range as shown below and conforming to the requirements as prescribed in Specification E 1, or in the Specification for IP Standard Thermometers.

Temperature Range	Thermometer Number	
	ASTM	IP
-37 to +21°C	71C	72C
-35 to +70°F	71F	72F

5.6.2 Temperature measuring devices other than those described in 5.6.1 are satisfactory for this test method, provided

that they exhibit the same temperature response as the equivalent mercury-in-glass thermometers.

5.7 *Weighing Bottles*, glass-stoppered, having a typical capacity of 15 to 25 mL.

5.8 *Evaporation Assembly*, consisting of an evaporating cabinet and connections, essentially as illustrated in Fig. 4, and capable of maintaining a temperature of $35 \pm 1^\circ\text{C}$ ($95 \pm 2^\circ\text{F}$) around the evaporation flask. Construct the jets with an inside diameter of 4 ± 0.2 mm for delivering a stream of clean, dry air vertically downward into the weighing bottle. Support each jet so that the tip is 15 ± 5 mm above the surface of the liquid at the start of the evaporation. Supply purified air at the rate of 2 to 3 L/min per jet. One way to purify the air is by passage through a tube of approximately 10-mm bore packed loosely to a height of approximately 200 mm with absorbent cotton. Periodically check the cleanliness of the air by evaporating 4 mL of methyl ethyl ketone by the procedure specified in 8.5. When the residue does not exceed 0.1 mg, the evaporation equipment is operating satisfactorily.

5.9 *Analytical Balance*, capable of reproducing weights to 0.1 mg.

5.10 *Wire Stirrer*—A piece of stiff wire, made of iron, stainless steel, or Nichrome wire of about No. 20 B & S (0.9 mm in diameter) or 16 swg gage, 250 mm long. A 10-mm diameter loop is formed at each end, and the loop at the bottom end is bent so that the plane of the loop is perpendicular to the wire.

6. Reagents

6.1 *Methyl Ethyl Ketone*, conforming to the specifications of the Committee on Analytical Reagents of the American Chemical Society.⁶

6.2 Store the solvent over anhydrous calcium sulfate (5 weight % of the solvent). Filter prior to use.

6.3 *Air supply*, clean and filtered.

NOTE 3—As an alternative, it is permissible to replace all references to “air” used in the solvent evaporation process with “nitrogen,” provided the nitrogen is clean and filtered. It should be noted, however, that the precision statements for the test method were determined using air only and that the precision associated with using nitrogen has not been determined.

7. Sample

7.1 If the sample of wax is 1 kg (2 lb) or less, obtain a representative portion by melting the entire sample and stirring thoroughly. For samples over 1 kg (2 lb), exercise special care to ensure obtaining a truly representative portion, bearing in mind that the oil may not be distributed uniformly throughout the sample, and that mechanical operations may express some of the oil.

⁶ *Reagent Chemicals, American Chemical Society Specifications*, American Chemical Society, Washington, DC. For suggestions on the testing of reagents not listed by the American Chemical Society, see *Analar Standards for Laboratory Chemicals*, BDH Ltd., Poole, Dorset, U.K., and the *United States Pharmacopeia and National Formulary*, U.S. Pharmacopeial Convention, Inc. (USPC), Rockville, MD.

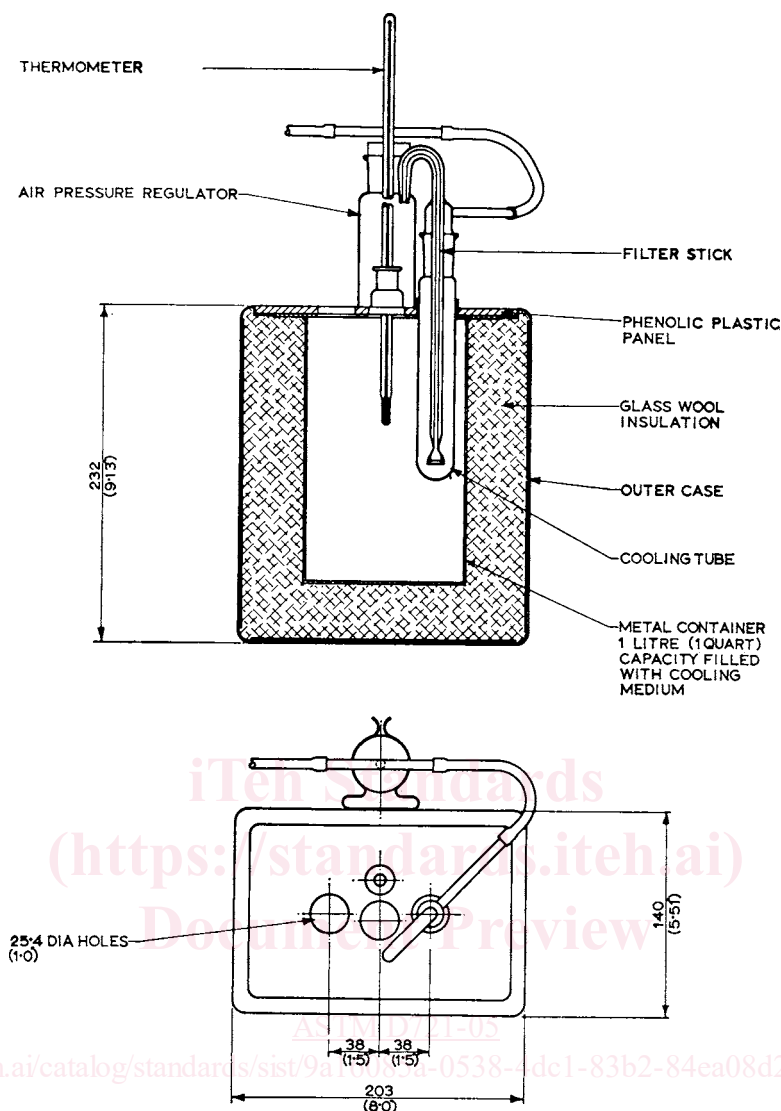

All dimensions are in millimetres (inches)

FIG. 2 Cooling Bath

8. Procedure

8.1 Melt a representative portion of the sample, using a water bath or oven maintained at 70 to 100°C (158 to 212°F). As soon as the wax is completely melted, thoroughly mix. Preheat the pipet or equivalent measuring device in order to prevent the solidification of wax in the tip, and withdraw a portion of the sample as soon as possible after the wax has melted. The mass of wax transferred to the test tube must be 1.00 ± 0.05 g. Allow the test tube to cool, and weigh to the nearest 1 mg.

NOTE 4—The weight of a test tube which is cleaned by means of solvents will not vary to a significant extent. Therefore, a tare weight may be obtained and used repeatedly.

8.2 Pipet 15 mL of methyl ethyl ketone into the test tube and place the latter just up to the level of its contents in a hot water or steam bath. Heat the solvent wax mixture, stirring up and

down with the wire stirrer, until a homogeneous solution is obtained. Exercise care to avoid loss of solvent by prolonged boiling.

NOTE 5—Very high-melting wax samples may not form clear solutions. Stir until the undissolved material is well dispersed as a fine cloud.

8.2.1 Plunge the test tube into an 800-mL beaker of ice water and continue to stir until the contents are cold. Remove the stirrer. Remove the test tube from the ice bath, wipe dry on the outside with a cloth, and weigh to the nearest 0.1 g.

NOTE 6—During this operation the loss of solvent through vaporizations should be less than 1%. The weight of the solvent is therefore practically a constant, and after a few samples are weighed, this weight, approximately 11.9 g, can be used as a constant factor.

8.3 Insert the temperature measuring device into the test tube and place the test tube containing the wax-solvent slurry in the cooling bath, which is maintained at $-34.5 \pm 1^\circ\text{C}$ ($-30 \pm 0.5^\circ\text{F}$). During this chilling operation it is important that