



Designation: ~~D 4318-00~~ Designation: D 4318 - 05

Standard Test Methods for Liquid Limit, Plastic Limit, and Plasticity Index of Soils¹

This standard is issued under the fixed designation D 4318; the number immediately following the designation indicates the year of original adoption or, in the case of revision, the year of last revision. A number in parentheses indicates the year of last reapproval. A superscript epsilon (ϵ) indicates an editorial change since the last revision or reapproval.

This standard has been approved for use by agencies of the Department of Defense.

1. Scope*

1.1 These test methods cover the determination of the liquid limit, plastic limit, and the plasticity index of soils as defined in Section 3 on Terminology.

1.2 Two methods for preparing test specimens are provided as follows: *Wet preparation method*, as described in 10.1. *Dry preparation method*, as described in 10.2. The method to be used shall be specified by the requesting authority. If no method is specified, use the wet preparation method.

1.2.1 The liquid and plastic limits of many soils that have been allowed to dry before testing may be considerably different from values obtained on non-dried samples. If the liquid and plastic limits of soils are used to correlate or estimate the engineering behavior of soils in their natural moist state, samples should not be permitted to dry before testing unless data on dried samples are specifically desired.

1.3 Two methods for determining the liquid limit are provided as follows: *Method A*, Multipoint test as described in Sections 11 and 12. *Method B*, One-point test as described in Sections 13 and 14. The method to be used shall be specified by the requesting authority. If no method is specified, use Method A.

1.3.1 The multipoint liquid limit method is generally more precise than the one-point method. It is recommended that the multipoint method be used in cases where test results may be subject to dispute, or where greater precision is required.

1.3.2 Because the one-point method requires the operator to judge when the test specimen is approximately at its liquid limit, it is particularly not recommended for use by inexperienced operators.

1.3.3 The correlation on which the calculations of the one-point method are based may not be valid for certain soils, such as organic soils or soils from a marine environment. It is strongly recommended that the liquid limit of these soils be determined by the multipoint method.

1.4 The plastic limit test is performed on material prepared for the liquid limit test.

1.5 The liquid limit and plastic limit of soils (along with the shrinkage limit) are often collectively referred to as the Atterberg limits. These limits distinguished the boundaries of the several consistency states of plastic soils.

1.6 The composition and concentration of soluble salts in a soil affect the values of the liquid and plastic limits as well as the water content values of soils (see Method D 2216). Special consideration should therefore be given to soils from a marine environment or other sources where high soluble salt concentrations may be present. The degree to which the salts present in these soils are diluted or concentrated must be given careful consideration.

1.7 The methods described herein are performed only on that portion of a soil that passes the 425- μm (No. 40) sieve. Therefore, the relative contribution of this portion of the soil to the properties of the sample as a whole must be considered when using these tests to evaluate properties of a soil.

1.8 The values stated in acceptable metric units are to be regarded as the standard, except as noted below. The values given in parentheses are for information only.

1.8.1 The standard units for the resilience tester covered in Annex A1 are inch-pound, not metric. The metric values given are for information only.

1.9 *This standard does not purport to address all of the safety concerns, if any, associated with its use. It is the responsibility of the user of this standard to establish appropriate safety and health practices and determine the applicability of regulatory limitations prior to use.*

¹ This standard is under the jurisdiction of ASTM Committee D18 on Soil and Rock and is the direct responsibility of Subcommittee D18.03 on Texture, Plasticity and Density Characteristics of Soils.

Current edition approved June 10, 2000. Published September 2000. Originally published as D4318-83. Last previous edition D4318-98.

Current edition approved March 1, 2005. Published April 2005. Originally approved in 1983. Last previous edition approved in 2000 as D 4318 - 00.

*A Summary of Changes section appears at the end of this standard.

2. Referenced Documents

2.1 ASTM Standards:²

- C 702 Practice for Reducing Field Samples of Aggregate to Testing Size
- D 75 Practice for Sampling Aggregates
- D 420 Guide to Site Characterization for Engineering, Design, and Construction Purposes
- D 653 Terminology Relating to Soil, Rock, and Contained Fluids
- D 1241 Specification for Materials for Soil-Aggregate Subbase, Base, and Surface Courses
- D 2216 Test Method for Laboratory Determination of Water (Moisture) Content of Soil and Rock by Mass
- D 2487 Practice for Classification of Soils for Engineering Purposes (Unified Soil Classification System)
- D 3282 Practice for Classification of Soils and Soil-Aggregate Mixtures for Highway Construction Purposes
- D 3740 Practice for Minimum Requirements for Agencies Engaged in the Testing and/or Inspection of Soil and Rock as Used in Engineering Design and Construction
- D 4753 Specification for Evaluating, Selecting, and Specifying Balances and Scales for Use in Soil, Rock, and Related Construction Materials Testing
- D 6026 Practice for Using Significant Digits in Geotechnical Data
- E 11 Specification for Wire-Cloth Sieves for Testing Purposes
- E 177 Practice for Use of the Terms Precision and Bias in ASTM Test Methods
- E 691 Practice for Conducting an Interlaboratory Study to Determine the Precision of a Test Method

3. Terminology

3.1 Definitions:

3.1.1 ~~The definitions of terms in this standard are in accordance with Terminology D 653.~~

3.1.1 For common definitions of terms in this standard, refer to Terminology D 653.

3.2 Description of Terms Specific to This Standard:

3.2.1

3.1.2 *Atterberg Limits*—Originally, six “limits of consistency” of fine-grained soils were defined by Albert Atterberg: the upper limit of viscous flow, the liquid limit, the sticky limit, the cohesion limit, the plastic limit, and the shrinkage limit. In current engineering usage, the term usually refers only to the liquid limit, plastic limit, and in some references, the shrinkage limit.

3.2.2

3.1.3 *consistency*—the relative ease with which a soil can be deformed.

3.2.3

3.1.4 *liquid limit (LL, w_L)*—the water content, in percent, of a soil at the arbitrarily defined boundary between the semi-liquid and plastic states.

3.2.3.1

3.1.4.1 *Discussion*—The undrained shear strength of soil at the liquid limit is considered to be approximately 2 kPa (0.28 psi).

3.2.4

3.1.5 *plastic limit (PL, w_p)*—the water content, in percent, of a soil at the boundary between the plastic and semi-solid states.

3.2.5

3.1.6 *plastic soil*—a soil which has a range of water content over which it exhibits plasticity and which will retain its shape on drying.

3.2.6

3.1.7 *plasticity index (PI)*—the range of water content over which a soil behaves plastically. Numerically, it is the difference between the liquid limit and the plastic limit.

3.2.7

3.1.8 *liquidity index*—the ratio, expressed as a percentage of (1) the water content of a soil minus its plastic limit, to (2) its plasticity index.

3.2.8

3.1.9 *activity number (A)*—the ratio of (1) the plasticity index of a soil to (2) the percent by mass of particles having an equivalent diameter smaller than 2 μm .

4. Summary of Test Method

4.1 The specimen is processed to remove any material retained on a 425- μm (No. 40) sieve. The liquid limit is determined by performing trials in which a portion of the specimen is spread in a brass cup, divided in two by a grooving tool, and then allowed to flow together from the shocks caused by repeatedly dropping the cup in a standard mechanical device. The multipoint liquid

² Annual Book of ASTM Standards, Vol 04.02.

² For referenced ASTM standards, visit the ASTM website, www.astm.org, or contact ASTM Customer Service at service@astm.org. For Annual Book of ASTM Standards volume information, refer to the standard's Document Summary page on the ASTM website.

limit, Method A, requires three or more trials over a range of water contents to be performed and the data from the trials plotted or calculated to make a relationship from which the liquid limit is determined. The one-point liquid limit, Method B, uses the data from two trials at one water content multiplied by a correction factor to determine the liquid limit.

4.2 The plastic limit is determined by alternately pressing together and rolling into a 3.2-mm (1/8-in.) diameter thread a small portion of plastic soil until its water content is reduced to a point at which the thread crumbles and can no longer be pressed together and re-rolled. The water content of the soil at this point is reported as the plastic limit.

4.3 The plasticity index is calculated as the difference between the liquid limit and the plastic limit.

5. Significance and Use

5.1 These test methods are used as an integral part of several engineering classification systems to characterize the fine-grained fractions of soils (see Practices D 2487 and D 3282) and to specify the fine-grained fraction of construction materials (see Specification D 1241). The liquid limit, plastic limit, and plasticity index of soils are also used extensively, either individually or together, with other soil properties to correlate with engineering behavior such as compressibility, hydraulic conductivity (permeability), compactibility, shrink-swell, and shear strength.

5.2 The liquid and plastic limits of a soil and its water content can be used to express its relative consistency or liquidity index. In addition, the plasticity index and the percentage finer than 2- μ m particle size can be used to determine its activity number.

5.3 These methods are sometimes used to evaluate the weathering characteristics of clay-shale materials. When subjected to repeated wetting and drying cycles, the liquid limits of these materials tend to increase. The amount of increase is considered to be a measure of a shale's susceptibility to weathering.

5.4 The liquid limit of a soil containing substantial amounts of organic matter decreases dramatically when the soil is oven-dried before testing. Comparison of the liquid limit of a sample before and after oven-drying can therefore be used as a qualitative measure of organic matter content of a soil (see Practice D 2487).

NOTE 1—The quality of the result produced by this standard is dependent on the competence of the personnel performing it and the suitability of the equipment and facilities used. Agencies that meet the criteria of Practice D 3740, generally, are considered capable of competent and objective testing/sampling/inspection/etc. Users of this standard are cautioned that compliance with Practice D 3740 does not in itself assure reliable results. Reliable results depend on many factors; Practice D 3740 provides a means of evaluating some of those factors.

6. Apparatus

6.1 *Liquid Limit Device*—A mechanical device consisting of a brass cup suspended from a carriage designed to control its drop onto a hard rubber base. Fig. 1 shows the essential features and critical dimensions of the device. The device may be operated by either a hand crank or electric motor.

6.1.1 *Base*—A hard rubber base having a Type D Durometer hardness of 80 to 90, and resilience rebound of at least 77 % but no more than 90 %. Conduct resilience tests on the finished base with the feet attached. Details for measuring the resilience of the base are given in Annex A1.

6.1.2 *Rubber Feet*, supporting the base, designed to provide isolation of the base from the work surface, and having a Type A Durometer hardness no greater than 60 as measured on the finished feet attached to the base.

6.1.3 *Cup*, brass, with a mass, including cup hanger, of 185 to 215 g.

6.1.4 *Cam*—Designed to raise the cup smoothly and continuously to its maximum height, over a distance of at least 180° of cam rotation, without developing an upward or downward velocity of the cup when the cam follower leaves the cam. (The preferred cam motion is a uniformly accelerated lift curve.)

NOTE 2—The cam and follower design in Fig. 1 is for uniformly accelerated (parabolic) motion after contact and assures that the cup has no velocity at drop off. Other cam designs also provide this feature and may be used. However, if the cam-follower lift pattern is not known, zero velocity at drop off can be assured by carefully filing or machining the cam and follower so that the cup height remains constant over the last 20 to 45° of cam rotation.

6.1.5 *Carriage*, constructed in a way that allows convenient but secure adjustment of the height-of-drop of the cup to 10 mm (0.394 in.), and designed such that the cup and cup hanger assembly is only attached to the carriage by means of a removable pin. See Fig. 2 for definition and determination of the height-of-drop of the cup.

6.1.6 *Motor Drive (Optional)*—As an alternative to the hand crank shown in Fig. 1, the device may be equipped with a motor to turn the cam. Such a motor must turn the cam at 2 ± 0.1 revolutions per second and must be isolated from the rest of the device by rubber mounts or in some other way that prevents vibration from the motor being transmitted to the rest of the apparatus. It must be equipped with an ON-OFF switch and a means of conveniently positioning the cam for height-of-drop adjustments. The results obtained using a motor-driven device must not differ from those obtained using a manually operated device.

6.2 *Flat Grooving Tool*—A tool made of plastic or noncorroding-metal having the dimensions shown in Fig. 3. The design of the tool may vary as long as the essential dimensions are maintained. The tool may, but need not, incorporate the gage for adjusting the height-of-drop of the liquid limit device.

NOTE 3—Prior to the adoption of this test method, a curved grooving tool was specified as part of the apparatus for performing the liquid limit test. The curved tool is not considered to be as accurate as the flat tool described in 6.2 since it does not control the depth of the soil in the liquid limit cup. However, there are some data which indicate that typically the liquid limit is slightly increased when the flat tool is used instead of the curved tool.

6.3 *Gage*—A metal gage block for adjusting the height-of-drop of the cup, having the dimensions shown in Fig. 4. The design

DIMENSIONS

LETTER	A ^Δ	B ^Δ	C ^Δ	E ^Δ	F	G	H	J ^Δ	K ^Δ	L ^Δ	M ^Δ
MM	54 ± 0.5	2 ± 0.1	27 ± 0.5	56 ± 2.0	32	10	16	60 ± 1.0	50 ± 2.0	150 ± 2.0	125 ± 2.0
LETTER	N	P	R	T	U ^Δ	V	W	Z			
MM	24	28	24	45	47 ± 1.0	3.8	13	6.5			

^Δ ESSENTIAL DIMENSIONS

CAM ANGLE DEGREES	CAM RADIUS
0	0.742 R
30	0.753 R
60	0.764 R
90	0.773 R
120	0.784 R
150	0.796 R
180	0.818 R
210	0.854 R
240	0.901 R
270	0.945 R
300	0.974 R
330	0.995 R
360	1.000 R

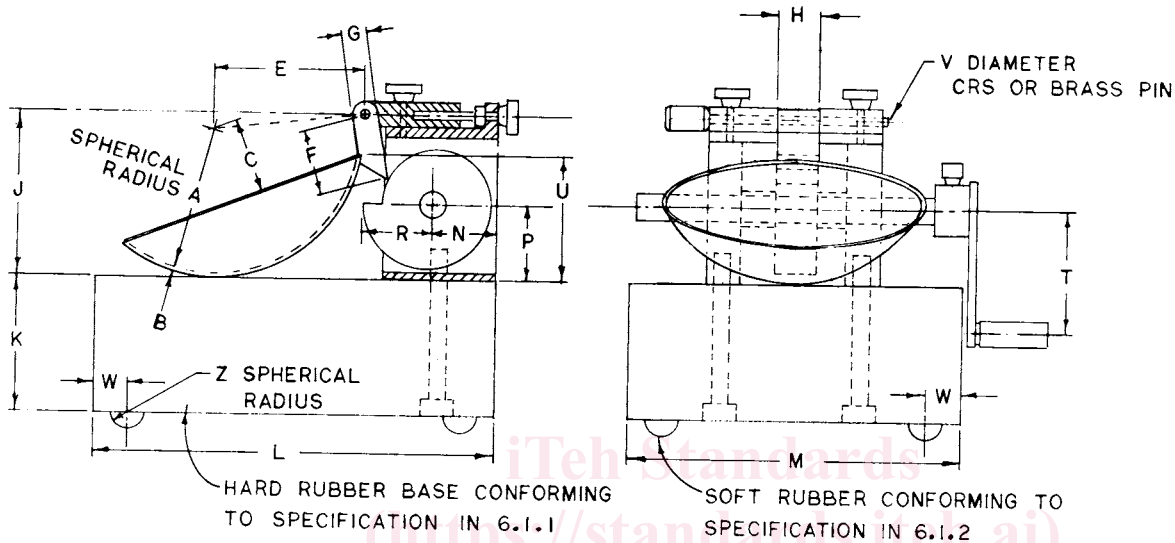

FIG. 1 Hand-Operated Liquid Limit Device

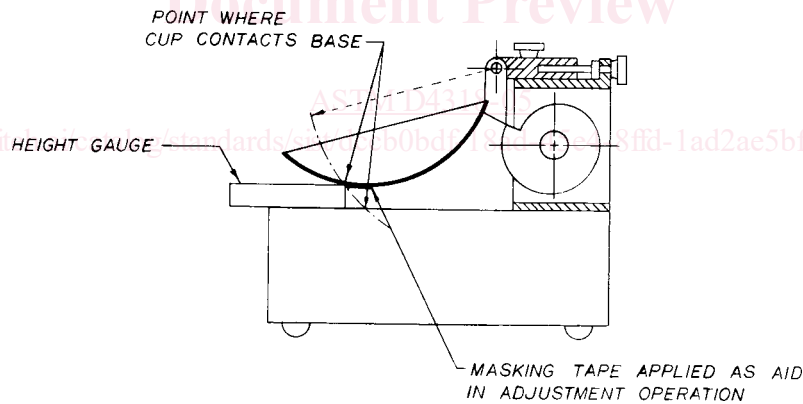

FIG. 2 Calibration for Height-of-Drop

of the tool may vary provided the gage will rest securely on the base without being susceptible to rocking, and the edge which contacts the cup during adjustment is straight, at least 10 mm (3/8 in.) wide, and without bevel or radius.

6.4 *Water Content Containers*—Small corrosion-resistant containers with snug-fitting lids for water content specimens. Aluminum or stainless steel cans 2.5 cm (1 in.) high by 5 cm (2 in.) in diameter are appropriate.

6.5 *Balance*, conforming to Specification D 4753, Class GP1 (readability of 0.01 g).

6.6 *Mixing and Storage Container*—A container to mix the soil specimen (material) and store the prepared material. During mixing and storage, the container shall not contaminate the material in any way, and prevent moisture loss during storage. A porcelain, glass, or plastic dish about 11.4 cm (4 1/2 in.) in diameter and a plastic bag large enough to enclose the dish and be folded over is adequate.

6.7 *Plastic Limit:*

6.7.1 *Ground Glass Plate*—A ground glass plate at least 30 cm (12 in.) square by 1 cm (3/8 in.) thick for rolling plastic limit threads.

DIMENSIONS

LETTER	A ^Δ	B ^Δ	C ^Δ	D ^Δ	E ^Δ	F ^Δ
MM	2 ± 0.1	11 ± 0.2	40 ± 0.5	8 ± 0.1	50 ± 0.5	2 ± 0.1
LETTER	G	H	J	K ^Δ	L ^Δ	N
MM	10 MINIMUM	13	60	10 ± 0.05	60 DEG ± 1 DEG	20

^Δ ESSENTIAL DIMENSIONS

[□] BACK AT LEAST 15 MM FROM TIP

NOTE: DIMENSION A SHOULD BE 1.9–2.0 AND DIMENSION D SHOULD BE 8.0–8.1 WHEN NEW TO ALLOW FOR ADEQUATE SERVICE LIFE

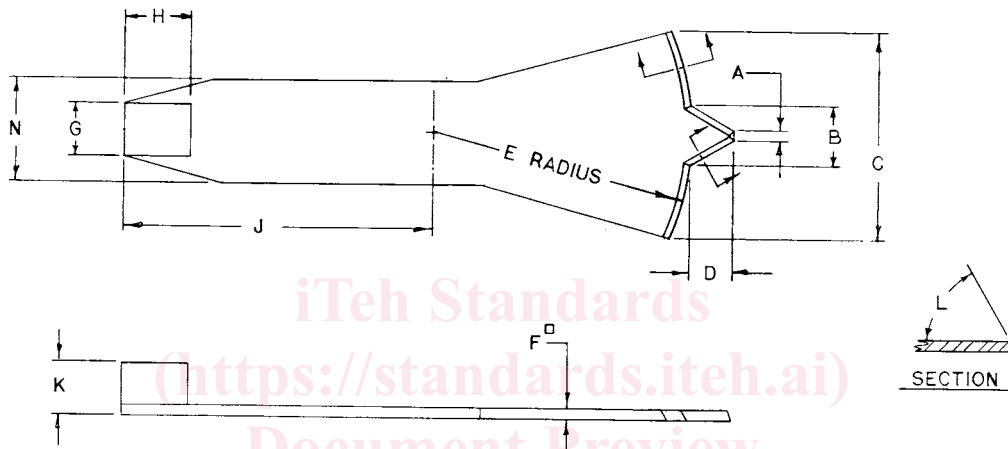
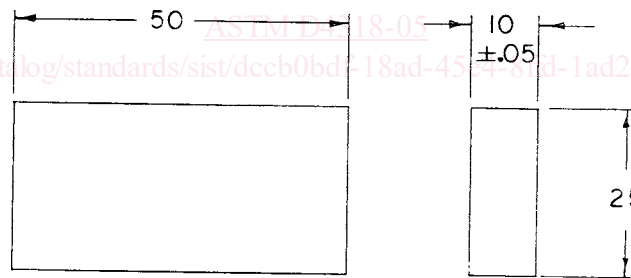

FIG. 3 Grooving Tool (Optional Height-of-Drop Gage Attached)



DIMENSIONS IN MILLIMETRES

FIG. 4 Height-of-Drop Gage

6.7.2 *Plastic Limit-Rolling Device (optional)*—A device made of acrylic conforming to the dimensions shown in Fig. 5.^{3,4} The type of unglazed paper attached to the top and bottom plate (see 16.2.2) shall be such that it does not add foreign matter (fibers, paper fragments, etc.) to the soil during the rolling process.

6.8 *Spatula*—A spatula or pill knife having a blade about 2 cm (3/4 in.) wide, and about 10 to 13 cm (3 to 4 in.) long.

6.9 *Sieve(s)*—A 200-mm (8-in.) diameter, 425- μ m (No. 40) sieve conforming to the requirements of Specification E 11 and having a rim at least 5 cm (2 in.) above the mesh. A 2.00-mm (No. 10) sieve meeting the same requirements may also be needed.

³ Annual Book of ASTM Standards, Vol 04.03.

³ The plastic limit-rolling device is covered by a patent (U.S. Patent No. 5,027,660).⁷ Interested parties are invited to submit information regarding the identification of an alternative(s) to this patented item to ASTM Headquarters. Your comments will receive careful consideration at a meeting of the responsible subcommittee, which you may attend.

⁴ Annual Book of ASTM Standards, Vol 04.08.

⁴ Bobrowski, L. J., Jr. and Griekspoor, D. M., "Determination of the Plastic Limit of a Soil by Means of a Rolling Device," *Geotechnical Testing Journal*, GTJODJ, Vol 15, No. 3, September 1992, pp. 284–287.

Dimensions:

IW—100 mm (4 in.), more or less
 L—200 mm (8 in.), more or less
 T-top—10 to 15 mm (3/8 to 1/2 in.) or thicker, see Note B
 T-bottom—5 mm (1/4 in.) or thicker
 H—Is the height of the slide rails. It shall equal 3.2 mm (1/8 in.) plus the total thickness of the unglazed paper that is not in contact with the top or bottom surface of the slide rails. The tolerance on this height is $\pm 1/4$ mm ($\pm 1/100$ in.), see Note C.
 W—See Note A.

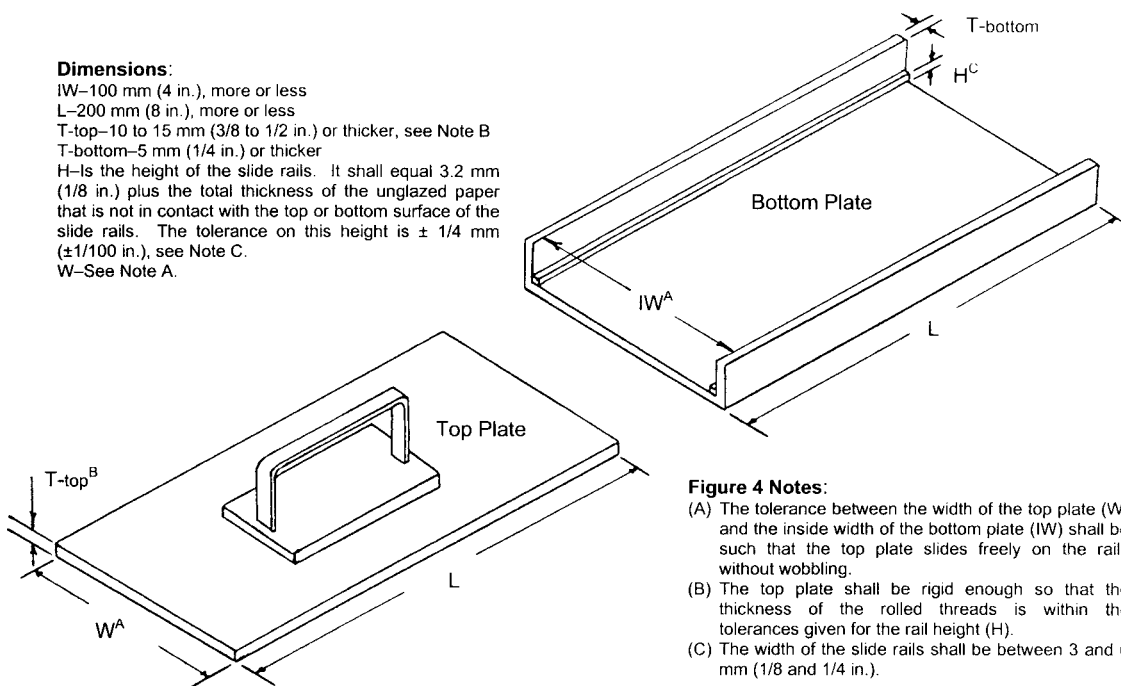

Figure 4 Notes:

- (A) The tolerance between the width of the top plate (W) and the inside width of the bottom plate (IW) shall be such that the top plate slides freely on the rails without wobbling.
- (B) The top plate shall be rigid enough so that the thickness of the rolled threads is within the tolerances given for the rail height (H).
- (C) The width of the slide rails shall be between 3 and 6 mm (1/8 and 1/4 in.).

FIG. 5 Plastic Limit-Rolling Device

6.10 *Wash Bottle*, or similar container for adding controlled amounts of water to soil and washing fines from coarse particles.

6.11 *Drying Oven*, thermostatically controlled, preferably of the forced-draft type, capable of continuously maintaining a temperature of $110 \pm 5^\circ\text{C}$ ($230 \pm 9^\circ\text{F}$) throughout the drying chamber.

6.12 *Washing Pan*, round, flat-bottomed, at least 7.6 cm (3 in.) deep, and slightly larger at the bottom than a 20.3-cm (8-in.) diameter sieve.

7. Reagents and Materials

7.1 *Purity of Water*— Where distilled water is referred to in this test method, either distilled or demineralized water may be used. See Note 7 covering the use of tap water.

8. Sampling and Specimen

8.1 Samples may be taken from any location that satisfies testing needs. However, Practices C 702, D 75, and D 420 should be used as guides for selecting and preserving samples from various types of sampling operations. Samples in which specimens will be prepared using the wet-preparation method (10.1) must be kept at their as-sampled water content prior to preparation.

8.1.1 Where sampling operations have preserved the natural stratification of a sample, the various strata must be kept separated and tests performed on the particular stratum of interest with as little contamination as possible from other strata. Where a mixture of materials will be used in construction, combine the various components in such proportions that the resultant sample represents the actual construction case.

8.1.2 Where data from these test methods are to be used for correlation with other laboratory or field test data, use the same material as used for those tests where possible.

8.2 *Specimen*—Obtain a representative portion from the total sample sufficient to provide 150 to 200 g of material passing the 425- μm (No. 40) sieve. Free flowing samples (materials) may be reduced by the methods of quartering or splitting. Non-free flowing or cohesive materials shall be mixed thoroughly in a pan with a spatula or scoop and a representative portion scooped from the total mass by making one or more sweeps with a scoop through the mixed mass.

9. Calibration of Apparatus

9.1 *Inspection of Wear:*

9.1.1 *Liquid Limit Device*—Determine that the liquid limit device is clean and in good working order. Check the following specific points.

9.1.1.1 *Wear of Base*— The spot on the base where the cup makes contact should be worn no greater than 10 mm ($3/8$ in.) in diameter. If the wear spot is greater than this, the base can be machined to remove the worn spot provided the resurfacing does not make the base thinner than specified in 6.1 and the other dimensional relationships are maintained.

9.1.1.2 *Wear of Cup*— Replace the cup when the grooving tool has worn a depression in the cup 0.1 mm (0.004 in.) deep or when the rim of the cup has been reduced to half its original thickness. Verify that the cup is firmly attached to the cup hanger.