



Standard Test Method for Life of Lubricating Greases in Ball Bearings at Elevated Temperatures¹

This standard is issued under the fixed designation D 3336; the number immediately following the designation indicates the year of original adoption or, in the case of revision, the year of last revision. A number in parentheses indicates the year of last reapproval. A superscript epsilon (ϵ) indicates an editorial change since the last revision or reapproval.

This standard has been approved for use by agencies of the Department of Defense.

1. Scope

1.1 This test method covers the evaluation of the performance of lubricating greases in ball bearings operating under light loads at high speeds and elevated temperatures.

1.2 The values stated in inch-pound units are to be regarded as standard. The values given in parentheses are mathematical conversions to SI units that are provided for information only and are not considered standard.

1.3 *This standard does not purport to address all of the safety concerns, if any, associated with its use. It is the responsibility of the user of this standard to establish appropriate safety and health practices and determine the applicability of regulatory limitations prior to use.* For specific warning statements, see 8.1.

2. Referenced Documents

2.1 *ASTM Standards:*²

A 600 Specification for Tool Steel High Speed

2.2 *ABMA Standard:*³

Standard 4, Tolerance Definitions and Gaging Practices for Ball and Roller Bearings

3. Summary of Test Method

3.1 A grease lubricated SAE No. 204 size ball bearing is rotated at 10 000 rpm under light load at a specified elevated temperature. Tests are continued until failure or completion of a specified number of hours of running time.

4. Significance and Use

4.1 This test method can be used to evaluate the ability of grease to provide adequate lubrication for extended periods of

ball bearings operating under light loads at high speeds and elevated temperatures.

5. Apparatus^{4,5}

5.1 *Test Spindle*⁶ (see Figs. 1-4), capable of operating at speeds of 10 000 rpm and temperatures as high as 371°C (700°F). The test bearing seat dimension shall be 19.99 to 20.00 mm (0.7870 to 0.7874 in.). For spindles having the test bearing and the support bearing in the same housing (CRC Type, Figs. 1-3) (Note 2) the internal construction of the spindle shall be such that the outboard support bearing, or both bearings are free to float axially in the housing. In designs where both bearings are free to float, the spindle shaft shall have a 0.508 to 0.762 mm (0.020 to 0.030 in.) free axial movement or end play. The outboard bearing seat dimension should be 19.99 to 20.00 mm (0.7870 to 0.7874 in.).

5.1.1 The test unit design (Fig. 1 and Fig. 2) should be such that a finger spring washer produces a 22 to 67 N (5 to 15 lbf) thrust load on the floating outboard support bearing.⁷

5.2 Bearing Housing:

5.2.1 *For CRC Type Spindles*—The bearing housing diameter shall be 47.005 to 47.021 mm (1.8506 to 1.8512 in.) to give proper bearing mounting. Construction shall be such that the test bearing is equipped with flush spacers or shields to confine the grease to the bearing. The spacers or shields shall have a clearance between the inside diameter and the shaft of 0.127 to 0.178 mm (0.005 to 0.007 in.) per side.

NOTE 1—This type of spindle is described in CRC Research Technique for the Determination of Performance Characteristics of Lubricating Grease in Antifriction Bearings at Elevated Temperature (CRC Designations L-35-54 and CRC L-35-62).

⁴ Complete apparatus is available from Falex Corp., 1020 Airpark Dr., Sugar Grove, IL 60554.

⁵ If you are aware of alternative suppliers, please provide this information to ASTM International Headquarters. Your comments will receive careful consideration at a meeting of the responsible technical committee,⁵ which you may attend.

⁶ Pope Machinery Corporation Grease Test Spindles No. P-1911 or P-6301A-HT (Fig. 1) and No. P-7605-B (Fig. 2); and Falex Corp. spindles of the type shown in Fig. 1 and Fig. 2 have been found satisfactory for this purpose.

⁷ The sole source of supply of the apparatus known to the committee at this time is Falex Part No. 643-187-070, Falex Corp. 1020 Airpark Dr., Sugar Grove, IL 60554.

¹ This test method is under the jurisdiction of ASTM Committee D02 on Petroleum Products and Lubricants and is the direct responsibility of Subcommittee D02.G0 on Lubricating Grease.

Current edition approved Nov. 1, 2005. Published November 2005. Originally approved in 1975. Last previous edition approved in 2002 as D 3336-97(2002) ^{ϵ 1}.

² For referenced ASTM standards, visit the ASTM website, www.astm.org, or contact ASTM Customer Service at service@astm.org. For *Annual Book of ASTM Standards* volume information, refer to the standard's Document Summary page on the ASTM website.

³ Available from American Bearing Manufacturers Assoc., 2025 M St., NW, Ste 800, Washington, DC 20036.

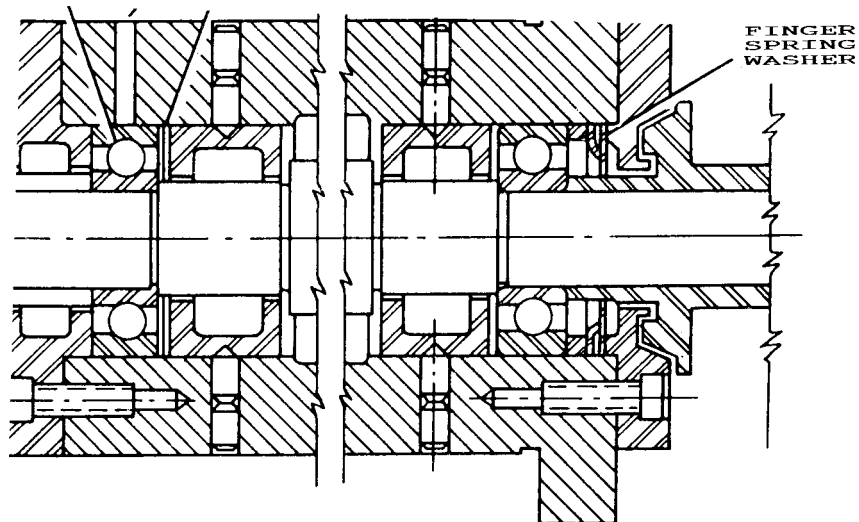

FIG. 1 Test Spindle (Both Bearings Floating)

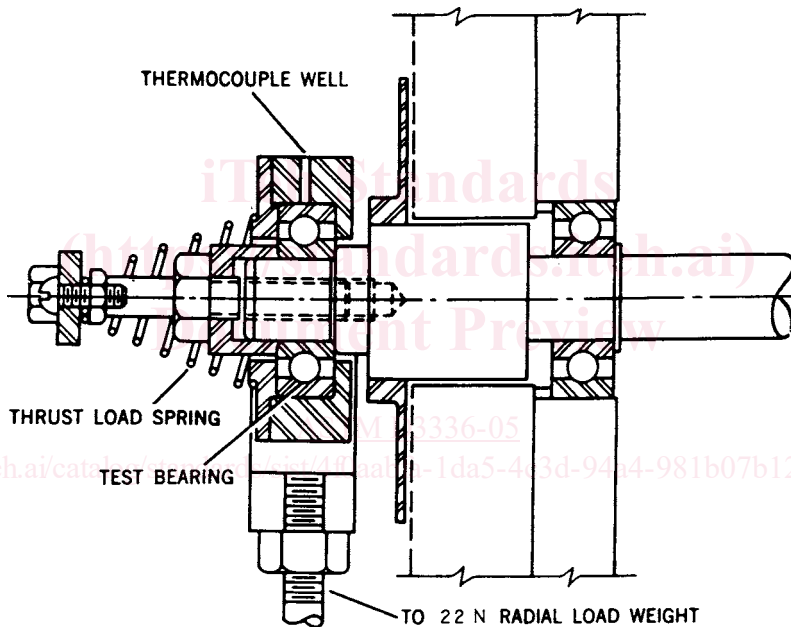

FIG. 2 Test Spindle (with Radial Load)

5.2.2 For Navy Type Spindles (Test Bearing Mounted Outside Spindle Housing)—The bearing housing shall be constructed of material similar to that of the test bearing and shall be tempered to retain dimensional stability at temperatures up to 371°C (700°F). Internal diameter shall be 47.005 to 47.021 mm (1.8506 to 1.8512 in.). The housing cover shall be flush fitting to confine the grease to the bearing. Provision shall be made for insertion in the housing of one or two small thermocouples which shall lightly press on and be in continual contact with the outer race of the test bearing. The housing shall be fitted with lugs to accommodate a yoke and added weight so that a radial load may be applied to the test bearing. A thrust load of 22 ± 2 N (5 ± 0.55 lbf) shall be applied to the outer race of the bearing by means of a helical spring calibrated at room temperature.

5.3 Motor Drive Assembly—Spindle bracket and constant belt tension motor drive assembly capable of providing spindle speeds up to $10\,000 \pm 200$ rpm by means of an endless belt. The motor shall be mounted so that a belt tension of approximately 67 N (15 lbf) can be maintained on the test spindle pulley.

5.4 Oven, removable, capable of producing a test temperature of 371°C (700°F) within 1½ h.

5.5 Control Equipment:

5.5.1 The temperature at the outside diameter of the test bearing shall be maintained within 3°C (5°F) of the specified test temperature. The temperature control equipment shall be adequate to maintain the temperature at the outer race of the test bearing within the limits specified by control of the oven

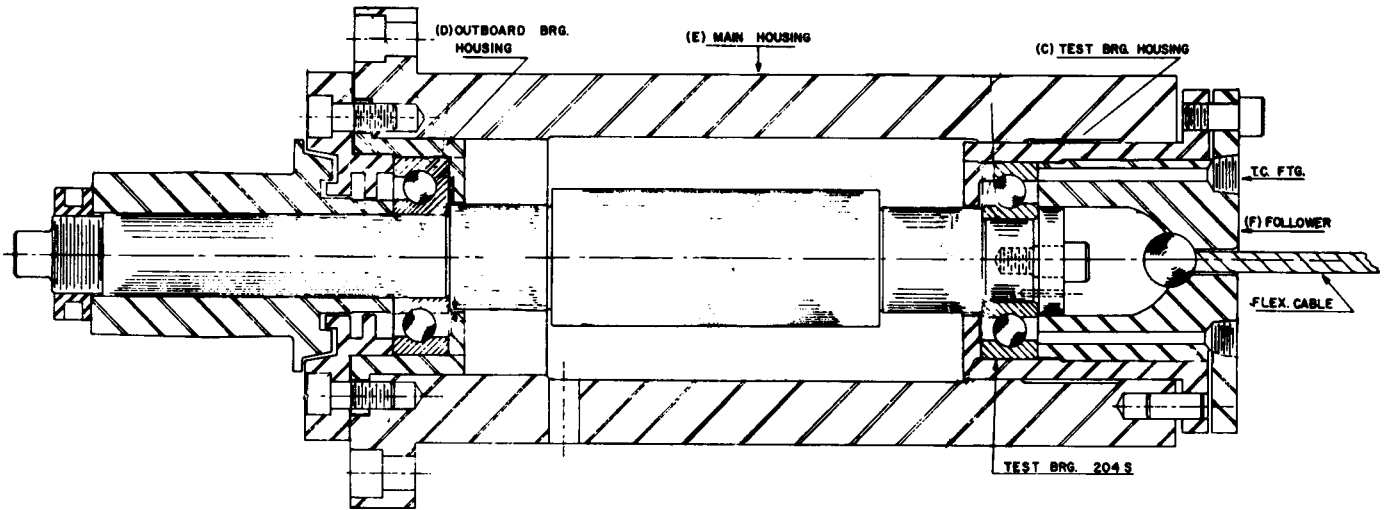

FIG. 3 Test Spindle Thrust Load Design

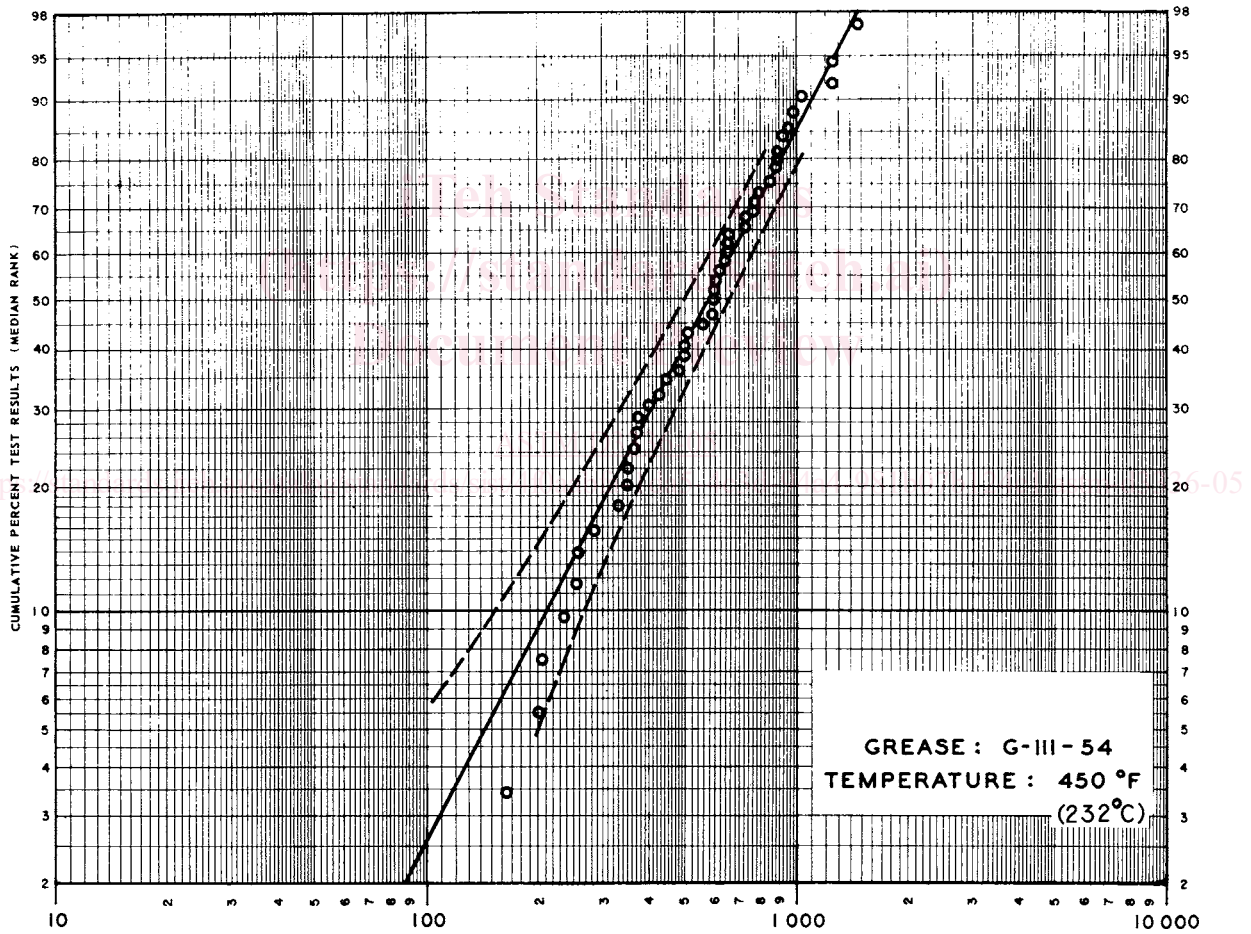

FIG. 4 G-III-54 Grease Life, Hours to Failure

temperature. The oven temperature shall be controlled by means of a thermocouple placed in the oven cavity.

5.5.2 Suitable equipment such as adjustable reset relay and overload device for shutting off oven heaters and drive motor