



Standard Test Method for Base Number Determination by Potentiometric Titration¹

This standard is issued under the fixed designation D 4739; the number immediately following the designation indicates the year of original adoption or, in the case of revision, the year of last revision. A number in parentheses indicates the year of last approval. A superscript epsilon (ϵ) indicates an editorial change since the last revision or reapproval.

1. Scope*

1.1 This test method covers a procedure for the determination of basic constituents in petroleum products and lubricants (Note 1). The test method resolves these constituents into groups having weak-base and strong-base ionization properties, provided the dissociation constants of the more strongly basic compounds are at least 1000 times that of the next weaker groups.

1.1.1 This test method covers base numbers up to 70. While it can be extended to higher base numbers, the precision of the test method for base numbers greater than 70 has not been determined.

NOTE 1—In new and used oils, the constituents which can be considered to have basic properties are primarily organic and inorganic bases, including amino compounds, although certain salts of heavy metals, salts of weak acids, basic salts of polyacidic compounds, and some additives such as inhibitors or detergents may show basic characteristics.

1.2 This test method can be used to indicate relative changes that occur in an oil during use under oxidizing or other service conditions regardless of the color or other properties of the resulting oil (Note 3). Although the analysis is made under closely specified conditions, the method is not intended to, and does not, result in reported basic properties which can be used under all service conditions to predict performance of an oil; for example, no overall relationship is known between bearing corrosion or the control of corrosive wear in the engine and base number.

NOTE 2—Test Method D 4739 was developed as an alternative for the former base number portion of Test Method D 664. Base numbers obtained by this method may or may not be numerically the same as those obtained by the former base number portion of Test Method D 664.²

NOTE 3—A color indicator titration method is also available in the Test Method D 974 and IP 139. The base numbers obtained by the potentiometric method may or may not be numerically the same as those obtained by Test Method D 974 or equivalent color indicator methods such as given in Federal Test Method Std. No. 791b. Potentiometric methods for base number are also available in Test Method D 2896.

¹ This test method is under the jurisdiction of ASTM Committee D02 on Petroleum Products and Lubricants and is the direct responsibility of Subcommittee D02.06 on Analysis of Lubricants.

Current edition approved Nov. 1, 2005. Published November 2005. Originally approved in 1987. Last previous edition approved in 2002 as D 4739–02.

² The base number portion was last published in the 1981 version.

1.3 The values stated in SI units are to be regarded as standard. No other units of measurement are included in this standard.

1.4 *This standard does not purport to address all of the safety concerns, if any, associated with its use. It is the responsibility of the user of this standard to establish appropriate safety and health practices and determine the applicability of regulatory limitations prior to use.*

2. Referenced Documents

2.1 *ASTM Standards:*³

D 664 Test Method for Acid Number of Petroleum Products by Potentiometric Titration

D 974 Test Method for Acid and Base Number by Color-Indicator Titration

D 1193 Specification for Reagent Water

D 2896 Test Method for Base Number of Petroleum Products by Potentiometric Perchloric Acid Titration

2.2 *IP Standard:*

IP 139 Test Method for Acid Number by Color-Indicator Titration Method, IP Standards for Petroleum and Its Products, Part 1. Methods for Analysis and Testing.⁴

2.3 *U.S. Federal Test Method:*

Federal Test Method Standard No. 791b Lubricants Liquid Fuels and Related Products; Methods of Testing⁵

3. Terminology

3.1 *Definitions:*

3.1.1 *base numbers, n*—the quantity of acid, expressed in milligrams of potassium hydroxide per gram of sample that is required to titrate a sample, dissolved in a specified solvent to a specified end point.

3.1.1.1 *Discussion*—In this test method, the sample is titrated to a meter reading corresponding to a freshly prepared nonaqueous acidic buffer solution.

³ For referenced ASTM standards, visit the ASTM website, www.astm.org, or contact ASTM Customer Service at service@astm.org. For *Annual Book of ASTM Standards* volume information, refer to the standard's Document Summary page on the ASTM website.

⁴ Available from Energy Institute, 61 New Cavendish St., London, W1G 7AR, U.K.

⁵ Available from Standardization Documents Order Desk, DODSSP, Bldg. 4, Section D, 700 Robbins Ave., Philadelphia, PA 19111-5098.

*A Summary of Changes section appears at the end of this standard.

3.2 Definitions of Terms Specific to This Standard:

3.2.1 *strong base number, n*—the quantity of acid, expressed in terms of the equivalent number of milligrams of potassium hydroxide per gram of sample, that is required to titrate a sample dissolved in the specified solvent from the initial meter reading to a meter reading corresponding to a freshly prepared basic buffer solution.

4. Summary of Test Method

4.1 The sample is dissolved in a mixture of toluene, propanol-2-ol (isopropyl alcohol), chloroform, and a small amount of water and titrated potentiometrically with alcoholic hydrochloric acid solution. The test results of this procedure are obtained by titration mode of fixed increment and fixed time additions of the titrant. An endpoint is selected from a titration curve according to the criteria given in 13.1 and used to calculate a base number.

5. Significance and Use

5.1 New and used petroleum products can contain basic constituents that are present as additives or as degradation products formed during service. The relative amount of these materials can be determined by titrating with acids. The base number is a measure of the amount of basic substances in the oil—always under the conditions of the test. The base number is used as a guide in the quality control of lubricating oil formulations. It is also sometimes used as a measure of lubricant degradation in service. Any condemning limits must be empirically established.

6. Apparatus

6.1 *Potentiometric Titrimeter*, automatic or manual, with capability of adding fixed increments of titrant at fixed time intervals (see Annex A1).

6.1.1 The titrimeter must automatically (or manually) control the rate of addition of titrant as follows: Delivery of titrant will be incremental; after delivery of precisely a 0.100-mL increment (see 6.1.2), the delivery is stopped and a fixed time period of 90 s is allowed to pass before another 0.100-mL increment of titrant is delivered. This procedure is repeated until the titration is completed.

6.1.2 The precision of addition of the 0.100-mL increments of titrant must be ± 0.001 mL for automatic titrators. For manual buret, it should be ± 0.005 mL. A higher incremental precision is required for an automatic buret because the total volume to the end point is summed from the individual increments, whereas with a manual buret it is read from a scale.

6.2 *Glass Indicating Electrode*, pH 0 to 14, general purpose.

6.3 *Reference Electrode*, Silver/Silver Chloride (Ag/AgCl) reference electrode, filled with 1–3 M LiCl in ethanol.

NOTE 4—Certain alternative electrode-electrolyte combinations have been found to give satisfactory results although the precision using these alternatives has not been determined. Combination electrodes may be used provided they conform to 8.3 and have a sufficient fast response time.

6.4 *Stirrer, Buret, Stand, Titration Vessel*, as specified in Annex A1 are required. A typical cell assembly is shown in Fig. 1.

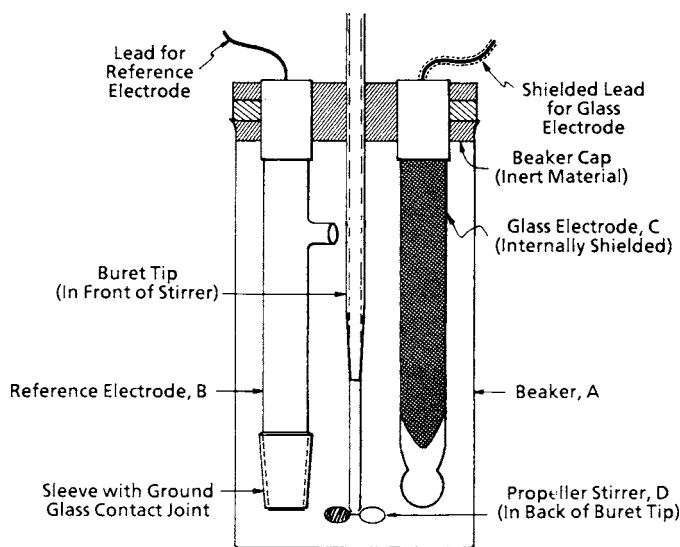

FIG. 1 Cell for Potentiometric Titration

7. Reagents

7.1 *Buffer, Nonaqueous Acid*—Add 10 mL of buffer stock solution A (see 7.3) to 100 mL of titration solvent. Use within 1 h.

7.2 *Buffer, Nonaqueous Base*—Add 10 mL of buffer stock solution B (see 7.4) to 100 mL of titration solvent. Use within 1 h.

7.3 *Buffer Stock Solution A*—Accurately weigh 24.2 ± 0.1 g of 2,4,6-trimethyl pyridine (γ -collidine), and transfer to a 1-L volumetric flask containing 100 mL of anhydrous isopropyl alcohol. Using a 250-mL graduated cylinder, add to the flask, while continuously stirring its contents, $150/N_{HCl} \pm 5$ mL of 0.2 M alcoholic HCl solution (N_{HCl} being the exact molarity of the HCl solution found by standardization). Dilute to the 1000-mL mark with anhydrous isopropyl alcohol, and mix thoroughly. Use within 2 weeks.

7.4 *Buffer Stock Solution B*—Accurately weigh 27.8 ± 0.1 g of *m*-nitrophenol and transfer to a 1-L volumetric flask containing 100 mL of anhydrous isopropyl alcohol. Using a 250-mL graduated cylinder, add to the flask while continuously stirring its contents, $50/N_{KOH} \pm 1$ mL of 0.2 M alcoholic KOH solution. (N_{KOH} being the exact molarity of the KOH solution found by standardization). Dilute to the 1000-mL mark with anhydrous isopropyl alcohol and mix thoroughly. Use within 2 weeks.

7.5 *Chloroform*, reagent grade. (**Warning**—Toxic and suspected carcinogen.)

7.6 *Chromic Acid Solution*—(**Warning**—Causes severe burns. Recognized carcinogen. Strong oxidizer.)

7.7 *Hydrochloric Acid Solution, Standard Alcoholic (0.1 M)*—Mix 9 mL of reagent grade hydrochloric acid (HCl, sp gr 1.19) (**Warning**—Toxic and corrosive), with 1 L of anhydrous isopropyl alcohol. Standardize frequently enough to detect normality changes of 0.0005 by potentiometric titration of approximately 8 mL (accurately measured) of the 0.1 M alcoholic KOH solution diluted with 125 mL CO₂-free water.

7.8 *Hydrochloric Acid Solution, Standard Alcoholic (0.2 M)*—Prepare and standardize as described in 7.7, but use 18 mL of HCl (sp gr 1.19).

7.9 *Lithium Chloride Electrolyte*—Prepare a solution of 1–3 M LiCl in ethanol.

7.10 *m-Nitrophenol*, $\text{NO}_2\text{C}_6\text{H}_4\text{OH}$, (**Warning**—Toxic), (mol weight 139.11), conforming to the following requirements:

Melting point	96 to 97°C
Color	Pale Yellow

7.10.1 Store the reagent in a brown glass bottle.

7.11 *Potassium Hydroxide Solution, Standard Alcoholic* (0.1 M)—Add 6 g of reagent grade potassium hydroxide (KOH) (**Warning**—Toxic and corrosive), to approximately 1 L of anhydrous isopropyl alcohol. Boil gently for 10 min to effect solution. Allow the solution to stand for 2 days and then filter the supernatant liquid through a fine sintered-glass funnel. Store the solution in a chemically resistant bottle. Dispense in a manner such that the solution is protected from atmospheric carbon dioxide (CO_2) by means of a guard tube containing soda lime or soda non-fibrous silicate absorbent (Ascarite, Carbosorb, or Indicarb), and such that it does not come into contact with cork, rubber, or saponifiable stopcock grease. Standardize frequently enough to detect normality changes of 0.0005 by potentiometric titration of weighed quantities of potassium acid phthalate dissolved in CO_2 -free water.

7.12 *Potassium Hydroxide Solution, Standard Alcoholic* (0.2 M)—Prepare, store, and standardize as directed in 7.11, but use 12 to 13 g of KOH to approximately 1 L of anhydrous isopropyl alcohol.

7.13 *Propanol-2-ol (Isopropyl Alcohol), Anhydrous*, (less than 0.1 % H_2O) (**Warning**—Flammable). If dry reagent cannot be procured, dry it by distillation through a multiple plate column, discarding the first 5 % of material distilling over and using the 95 % remaining. Also, drying can be accomplished using molecular sieves such as Linde Type 4A, by passing the solvent upward through a molecular sieve column using 1 part of molecular sieve per 10 parts of solvent. (**Warning**—It has been reported that, if not inhibited against it, propanol-2-ol can contain peroxides. When this occurs, an explosive mixture is possible when the storage vessel or other equipment such as a dispensing bottle, are near empty and approaching dryness.)

7.14 *Purity of Reagents*—Reagent-grade chemicals shall be used in all tests. Unless otherwise indicated, it is intended that all reagents shall conform to the specifications of the Committee on Analytical Reagents of the American Chemical Society, where such specifications are available.⁶ Other grades may be used, provided it is first ascertained that the reagent is of sufficiently high purity to permit its use without lessening the accuracy of the determination.

7.14.1 Commercially available solutions may be used in place of laboratory preparations provided the solutions have been certified as equivalent.

7.14.2 Alternate volumes of solutions may be prepared provided the final solution concentration is equivalent.

7.15 *Purity of Water*—Unless otherwise indicated, references to water shall be understood to mean reagent water as defined by Type III of Specification D 1193.

7.16 *Titration Solvent*—In a brown reagent bottle, add 30 mL of water to 1 L of isopropyl alcohol and mix thoroughly. Add 1 L each of toluene and chloroform and mix thoroughly.

7.17 *Toluene*, reagent grade. (**Warning**—Extremely flammable.)

7.18 *2,4,6-Trimethyl Pyridine (γ -Collidine)*, $(\text{CH}_3)_3\text{C}_5\text{H}_2\text{N}$, (**Warning**—Toxic), (mol weight 121.18) conforming to the following requirements:

Boiling range	168 to 170°C
Refractive index n_D^{20}	1.4982 ± 0.0005
Color	colorless

7.18.1 Store the reagent over activated alumina and keep it in a brown glass bottle.

8. Preparation of Electrode System

8.1 *Maintenance of Electrodes*—Clean the glass electrode (**Note 5**) at frequent intervals (not less than once every week during continual use) by immersing in cold chromic acid cleaning solution (**Warning**—Causes severe burns. Recognized carcinogen. Strong oxidizer). Drain the calomel electrode at least once each week and refill with fresh LiCl electrolyte as far as the filling hole. Maintain the electrolyte level in the reference electrode above that of the liquid in the titration beaker at all times. When not in use, immerse the lower halves of the electrodes in either water (glass) or the LiCl in isopropyl alcohol electrolyte (reference). Do not allow them to remain immersed in titration solvent for any appreciable period of time between titrations. While the electrodes are not extremely fragile, handle them carefully at all times.

NOTE 5—Cleaning the electrodes thoroughly, keeping the ground-glass joint free of foreign materials, and regular testing of the electrodes are important in obtaining repeatable potentials, since contamination can introduce uncertain, erratic, and unnoticeable liquid contact potentials.⁷ While this is of secondary importance when end points are chosen from inflection points in the titration curve, it is quite serious when end points are chosen at arbitrarily-fixed cell potentials (that is, the nonaqueous acidic buffer potential).

8.2 *Preparation of Electrodes*, Before and after using, blot-dry the glass electrode thoroughly with a clean cloth or a soft absorbent tissue and rinse with water. Wipe the reference electrode with a cloth or tissue, carefully remove the ground-glass sieve, and thoroughly wipe both ground surfaces. Replace the sleeve loosely and allow a few drops of electrolyte to drain through to flush the ground-glass joint (**Note 5**). Wet the ground surfaces thoroughly with electrolyte, set the sleeve firmly in place, and rinse the electrode with water. Prior to each titration, soak the prepared electrodes in water for at least 5 min immediately before use and touch the tips of the electrodes with a dry cloth or tissue to remove the excess water.

⁶ *Reagent Chemicals, American Chemical Society Specifications*, American Chemical Society, Washington, DC. For suggestions on the testing of reagents not listed by the American Chemical Society, see *Analar Standards for Laboratory Chemicals*, BDH Ltd., Poole, Dorset, U.K., and the *United States Pharmacopeia and National Formulary*, U.S. Pharmacopeial Convention, Inc. (USPC), Rockville, MD.

⁷ For a detailed discussion of the need for care in preparation of the electrodes, see Lykken, L., Porter, P., Ruliffson, H. D., and Tuemmler, F. D., "Potentiometric Determination of Acidity in Highly Colored Oils," *Industrial and Engineering Chemistry*, Analytical Edition, IENAA, Vol 16. 1944, pp. 219–234.

8.3 *Testing of Electrodes*—Test the meter-electrode combination (**Note 6**) when first put into use or when new electrodes are installed and retest at intervals thereafter by dipping the electrodes into a well-stirred mixture of 100 mL of the titration solvent and 1.0 to 1.5 mL of 0.1 *M* alcoholic KOH solution. For the meter-electrode combination to be suitable for use, the potential between the electrodes must change by more than 0.480 V from the potential between the same electrodes when dipped in the nonaqueous acidic buffer solution.

NOTE 6—Considerably more sensitive electrodes are now available that will show a potential change of at least 0.590 V under these conditions, and their use is recommended.

NOTE 7—See **Appendix X2** for a possible procedure to check the electrode performance.

9. Standardization of Apparatus

9.1 *Determination of Meter Readings for the Nonaqueous Buffer Solution Corresponding to Base End Point*—To ensure comparable selection of end points with the meter described in **A1.1.1**, determine daily for each electrode pair, the meter reading obtained with the freshly prepared nonaqueous acidic buffer solution to be used for the determination of base numbers, and with the freshly prepared nonaqueous basic buffer solution to be used for the determination of strong base numbers.

NOTE 8—The response of different glass electrodes to hydrogen ion activity is not the same. Therefore, it is necessary to establish regularly for each electrode system the meter readings corresponding to the acidic and basic buffer solutions arbitrarily selected to represent the end point.

9.2 Prepare the electrodes as described in **8.2**, immerse them in the appropriate nonaqueous buffer solution, and stir for 5 min, maintaining the temperature of the buffer solution at a temperature within 2°C of that at which the titrations are to be made. Read the cell voltage. The reading so obtained in the acidic buffer solution is taken as the end point for the base number if an inflection is not observed as specified in **12.1**, and the reading obtained in the basic buffer solution is taken as the end point for the strong base number.

10. Preparation of Sample of Used Oil

10.1 Strict observation of the sampling procedure is necessary, since the sediment itself is acidic or basic or has absorbed acidic or basic material from the sample. Failure to obtain a representative sample negates a meaningful value obtained.

NOTE 9—As used oils can change appreciably in storage, samples should be tested as soon as possible after removal from the lubricating system; and the dates of sampling and testing shall be noted.

10.2 Heat the sample (**Note 10**) of used oil to 60 ± 5°C in the original container and agitate the sample until all of the sediment is homogeneously suspended in the oil. If the original container is a can, or if it is glass and more than three-fourths full, transfer the entire sample to a clear-glass bottle having a capacity at least one-third greater than the volume of the sample. Transfer all traces of sediment from the original container to the bottle by vigorous agitation of portions of the sample in the original container.

10.3 After complete suspension of all sediment, strain the sample or a convenient aliquot through a 150-µm (100-mesh) screen for the removal of large contaminated particles.

NOTE 10—When samples are visibly free of sediment, the heating procedures described can be omitted.

11. Procedure for Base Number and Strong Base Number

11.1 Calculate the quantity of sample required for its expected base number as follows:

$$A = 7/E \quad (1)$$

where:

A = approximate mass of sample, g and

E = expected base number.

11.1.1 Take a maximum of 5 g and a minimum of 0.1 g for analysis. The precision of weighing is as follows:

Size of Sample, g	Precision of Weighing g
1–5	0.005
0.1–1	0.002

11.2 Into a 250-mL titration beaker or a suitable titration vessel, introduce a weighed quantity of sample as prescribed in **11.1.1** and add 125 mL of titration solvent (**Note 11**). Prepare the electrodes as directed in **8.2**. Place the beaker or titration vessel on the titration stand and adjust its position so that the electrodes are about half immersed. Start the stirrer, and stir throughout the determination at a rate sufficient to produce vigorous agitation without spattering and without stirring air into the solution.

NOTE 11—Some automatic titrators do not accept a beaker size that contains 125 mL of titration solvent. In such cases, a lesser amount of solvent in the range from 75 to 100 mL is acceptable.

11.3 Select and fill a suitable buret with the 0.1 *M* alcoholic HCl solution and place the buret in position on the titration assembly, taking care that the tip is immersed about 25 mm in the liquid in titration vessel. Record the initial buret and meter (cell potential) readings.

11.4 *Titration*—The reaction of the hydrochloric acid with the basic components is very slow with most titrations for base number. As a result, these titrations are not at equilibrium. Because of this, the titration conditions are tightly specified and must be strictly adhered to in order to achieve the precision as stated.

NOTE 12—See **Appendix X1** for techniques for reducing the titration time of a sample. Pre-dosing techniques have been found to provide satisfactory results although the precision using these techniques has not been determined.

11.4.1 Whether the titration is carried out manually or automatically, the following procedure of *fixed increment, fixed time* addition of titrant must be followed. Add 0.1 *M* HCl in increments of 0.100 mL throughout the titration with a 90-s pause between each incremental addition. Take millivolt readings at the end of each 90 s interval. Continue as above until a potential is reached which is 100 mV past the meter reading corresponding to that found for the standard acidic buffer solution (acidic buffer potential). If the volume of titrant required to reach this potential (100 mV past the acidic buffer potential) is greater than 4.0 mL, reduce the sample size by one-half and repeat the titration.

11.4.1.1 The meter readings of potential difference are plotted manually or automatically against the respective volumes of titrant, and the end point taken as described in **12.1**.