Road vehicles — Sheath-type glow-plugs — General requirements and test methods

Véhicules routiers — Bougies de préchauffage du type à fourreau — Exigences générales et méthodes d'essai

iTeh STANDARD PREVIEW
(standards.iteh.ai)

[ISO 7578:2008](https://standards.iteh.ai/catalog/standards/sist/bfc2cade-12ef-4e56-96d1-74faa8cde216/iso-7578-2008)

<https://standards.iteh.ai/catalog/standards/sist/bfc2cade-12ef-4e56-96d1-74faa8cde216/iso-7578-2008>



PDF disclaimer

This PDF file may contain embedded typefaces. In accordance with Adobe's licensing policy, this file may be printed or viewed but shall not be edited unless the typefaces which are embedded are licensed to and installed on the computer performing the editing. In downloading this file, parties accept therein the responsibility of not infringing Adobe's licensing policy. The ISO Central Secretariat accepts no liability in this area.

Adobe is a trademark of Adobe Systems Incorporated.

Details of the software products used to create this PDF file can be found in the General Info relative to the file; the PDF-creation parameters were optimized for printing. Every care has been taken to ensure that the file is suitable for use by ISO member bodies. In the unlikely event that a problem relating to it is found, please inform the Central Secretariat at the address given below.

iTeh STANDARD PREVIEW
(standards.iteh.ai)

ISO 7578:2008

<https://standards.iteh.ai/catalog/standards/sist/bfc2cade-12ef-4e56-96d1-74faa8cde216/iso-7578-2008>



COPYRIGHT PROTECTED DOCUMENT

© ISO 2008

All rights reserved. Unless otherwise specified, no part of this publication may be reproduced or utilized in any form or by any means, electronic or mechanical, including photocopying and microfilm, without permission in writing from either ISO at the address below or ISO's member body in the country of the requester.

ISO copyright office
Case postale 56 • CH-1211 Geneva 20
Tel. + 41 22 749 01 11
Fax + 41 22 749 09 47
E-mail copyright@iso.org
Web www.iso.org

Published in Switzerland

Foreword

ISO (the International Organization for Standardization) is a worldwide federation of national standards bodies (ISO member bodies). The work of preparing International Standards is normally carried out through ISO technical committees. Each member body interested in a subject for which a technical committee has been established has the right to be represented on that committee. International organizations, governmental and non-governmental, in liaison with ISO, also take part in the work. ISO collaborates closely with the International Electrotechnical Commission (IEC) on all matters of electrotechnical standardization.

International Standards are drafted in accordance with the rules given in the ISO/IEC Directives, Part 2.

The main task of technical committees is to prepare International Standards. Draft International Standards adopted by the technical committees are circulated to the member bodies for voting. Publication as an International Standard requires approval by at least 75 % of the member bodies casting a vote.

Attention is drawn to the possibility that some of the elements of this document may be the subject of patent rights. ISO shall not be held responsible for identifying any or all such patent rights.

ISO 7578 was prepared by Technical Committee ISO/TC 22, *Road vehicles*, Subcommittee SC 1, *Ignition equipment*.

This fourth edition cancels and replaces the third edition (ISO 7578:2001), which has been technically revised.

iTeh STANDARD PREVIEW
(standards.iteh.ai)

[ISO 7578:2008](https://standards.iteh.ai/catalog/standards/sist/bfc2cade-12ef-4e56-96d1-74faa8cde216/iso-7578-2008)

<https://standards.iteh.ai/catalog/standards/sist/bfc2cade-12ef-4e56-96d1-74faa8cde216/iso-7578-2008>

iTeh STANDARD PREVIEW
(standards.iteh.ai)

ISO 7578:2008

<https://standards.iteh.ai/catalog/standards/sist/bfc2cade-12ef-4e56-96d1-74faa8cde216/iso-7578-2008>

Road vehicles — Sheath-type glow-plugs — General requirements and test methods

1 Scope

This International Standard specifies general requirements and test methods for sheath-type glow-plugs. Detailed test condition(s) and/or requirement(s) are agreed between the glow-plug manufacturers and the engine manufacturer. It is applicable to those sheath-type glow-plugs conforming to ISO 6550-1, ISO 6550-2, ISO 6550-3 and ISO 6550-4, used in compression ignition (diesel) engines.

2 Normative references

The following referenced documents are indispensable for the application of this document. For dated references, only the edition cited applies. For undated references, the latest edition of the referenced document (including any amendments) applies.

ISO 6550-1, *Road vehicles — Sheath-type glow-plugs with conical seating and their cylinder head housing — Part 1: M14 × 1,25 glow-plugs*

ISO 6550-2, *Road vehicles — Sheath-type glow-plugs with conical seating and their cylinder head housing — Part 2: M12 × 1,25 glow-plugs*

ISO 6550-3, *Road vehicles — Sheath-type glow-plugs with conical seating and their cylinder head housing — Part 3: M10 glow-plugs*

ISO 6550-4, *Road vehicles — Sheath-type glow-plugs with conical seating and their cylinder head housing — Part 4: M8 × 1 glow-plugs*

IEC 60068-2-6, *Environmental testing — Part 2-6: Tests — Test Fc: Vibration (sinusoidal)*

3 Terms and definitions

For the purposes of this document, the following terms and definitions apply.

3.1

nominal voltage

voltage as marked on the housing of the glow-plug

NOTE The nominal voltage of the glow-plug is generally not identical to the supply voltage of the electrical system.

3.2

test voltage

voltage(s) applied to the glow-plug under test

4 Test methods and requirements

4.1 General

If not otherwise specified, all tests shall be carried out at room temperature (RT) (23 ± 5) °C.

4.2 Gas tightness

4.2.1 Test

Mount the sample on a test assembly with the tightening torque as specified in the relevant part of ISO 6550. Subject the sample to a pressure of 4 MPa [40 bar]¹⁾ above ambient air pressure on the sheath end for a duration of 15 s. Use air, nitrogen, carbon dioxide or any other detection gas.

4.2.2 Requirements

The measured total leakage shall not exceed 2 cm³/min. If neither air nor nitrogen is used, the leakage rate shall be converted to that of air using the specific volume of the detection gas.

4.3 Thermal characteristic

4.3.1 Test sample preparation

Before the test, pre-heat the sample to oxidation at the nominal voltage of the glow-plug and then allow it to cool to RT. The time for oxidation shall be as agreed between the glow-plug manufacturer and the engine manufacturer, e.g. three times the duration of the glow cycle.

4.3.2 Test

ISO 7578:2008

<https://standards.iteh.ai/catalog/standards/sist/bfc2cade-12ef-4e56-96d1->

Carry out the test using a test installation in accordance with Figure 18 (see Table 1), equipped with a cooling device by which the temperature can be maintained below 30 °C, measured at the seating of the glow-plug housing.

If the thermal behaviour is measured in accordance with a specific application, this shall be by agreement between the glow-plug manufacturer and the engine manufacturer.

Carry out the test at the test voltage(s) of the glow-plug as specified in the description of the glow plug system.

Temperature measurements shall be made without direct contact.

1) 1 bar = 0,1 MPa = 10⁵ Pa; 1 MPa = 1 N/mm².

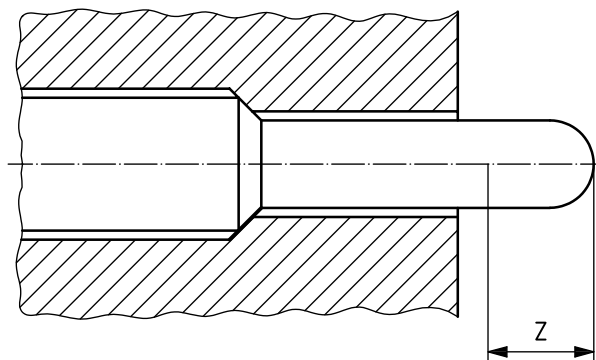
**Key**

Z maximum measuring zone

Figure 1 — Test installation

4.3.3 Requirements

The hottest point of standard warm-up sheath-type glow-plugs shall be within the measuring zone, Z, as shown in Figure 1. Z shall have a maximum length of 8 mm.

The temperature/time characteristic of the glow-plug shall be agreed between the glow-plug manufacturer and the engine manufacturer.

4.4 Resistance at room temperature**4.4.1 Test**

ISO 7578:2008
<https://standards.iteh.ai/catalog/standards/sist/bfc2cade-12ef-4e56-96d1-746a8cde316/iso-7578-2008>

Use a suitable measuring device which does not distort the resistance (e.g. 4-pole measuring device).

4.4.2 Requirement

The measured resistance shall be as agreed between the glow-plug manufacturer and the engine manufacturer.

4.5 Current characteristic**4.5.1 Test**

Use the test installation as specified in 4.3.2. Record the current characteristic by measuring the initial current, its gradient and the current at thermal equilibrium.

4.5.2 Requirement

The recorded characteristics shall be as agreed between the glow-plug manufacturer and the engine manufacturer.

4.6 Higher voltage

4.6.1 Test

Use the test installation as specified in 4.3.2. Apply a test voltage of 130 % of the nominal voltage of the glow-plug for the duration (15 ± 1) s.

4.6.2 Requirement

After the test, the glow-plug shall still meet the requirements of 4.3, 4.4 and 4.5.

4.7 Vibration (sinusoidal)

4.7.1 Test method

The glow-plug, mounted as provided for and tightened as specified, shall be subjected to a vibration test of type Fc in accordance with the test method in IEC 60068-2-6, using the parameters given in Table 1.

Table 1 — Values for vibration test

Frequency <i>f</i> Hz	Amplitude mm	Acceleration
50 ≤ <i>f</i> ≤ 160	0,3	—
160 < <i>f</i> ≤ 500	—	30 g (294 m/s ²)
Sweep rate:		1 octave/min
Vibration directions:		glow-plug axis and perpendicular
Duration:		8 h in each direction

4.7.2 Requirement

After the test specified in 4.7.1, the glow-plug shall show no visual damage and shall meet the requirements mutually agreed between the glow-plug manufacturer and the engine manufacturer.

4.8 Endurance

4.8.1 Test

The test conditions shall be agreed between the glow-plug manufacturer and the engine manufacturer. The agreed conditions shall include at least the following:

- number of cycles,
- voltage characteristic,
- installation (i.e. in accordance with 4.3.2 or in a simulated cylinder head),
- environmental condition (e.g. air speed and temperature),
- cooling, and
- cycle start temperature.

4.8.2 Requirement

The glow-plug manufacturer and the engine manufacturer shall agree on the performance.

5 Marking and labelling

The glow-plug shall be permanently marked with at least the following:

- the nominal voltage of the glow-plug, and
- the manufacturer's name, trademark or symbol.

iTeh STANDARD PREVIEW
(standards.iteh.ai)

[ISO 7578:2008](https://standards.iteh.ai/catalog/standards/sist/bfc2cade-12ef-4e56-96d1-74faa8cde216/iso-7578-2008)

<https://standards.iteh.ai/catalog/standards/sist/bfc2cade-12ef-4e56-96d1-74faa8cde216/iso-7578-2008>