



Standard Test Method for Evaluation of Automotive Engine Oils in the Sequence VIII Spark-Ignition Engine (CLR Oil Test Engine)¹

This standard is issued under the fixed designation D 6709; the number immediately following the designation indicates the year of original adoption or, in the case of revision, the year of last revision. A number in parentheses indicates the year of last reapproval. A superscript epsilon (ϵ) indicates an editorial change since the last revision or reapproval.

INTRODUCTION

This test method can be used by any properly equipped laboratory without outside assistance. However, the ASTM Test Monitoring Center (TMC)² offers a very valuable service to the test laboratory; the Center provides reference oils and an assessment of the test results obtained on those oils by the laboratory (see [Appendix X1](#)). By this means, the laboratory will know whether their use of the test method gives results statistically similar to those obtained by other laboratories. Furthermore, various agencies require that a laboratory utilize the TMC services in seeking qualification of oils against specifications. For example, the American Petroleum Institute (API) imposes such a requirement, in connection with several engine lubricating oil specifications.

Accordingly, this test method is written for use by laboratories that utilize the TMC services. Laboratories that choose not to use those services may simply ignore those portions of the test method that refer to the TMC.

This test method may be modified by means of Information Letters issued by the TMC. In addition, the TMC may issue supplementary memoranda related to the test method (see [Annex A3](#)).

1. Scope

1.1 This test method covers the evaluation of automotive engine oils (SAE grades 5W, 10W, 20, 30, 40, and 50, and multiviscosity grades) intended for use in spark-ignition gasoline engines. The test procedure is conducted using a carbureted, spark-ignition Cooperative Lubrication Research (CLR) Oil Test Engine (also referred to as the Sequence VIII test engine in this test method) run on unleaded fuel. An oil is evaluated for its ability to protect the engine and the oil from deterioration under high-temperature and severe service conditions. The test method can also be used to evaluate the viscosity stability of multiviscosity-graded oils. Companion test methods used to evaluate engine oil performance for specification requirements are discussed in the latest revision of Specification [D 4485](#).

1.2 Correlation of test results with those obtained in automotive service has not been established. Furthermore, the results obtained in this test are not necessarily indicative of results that will be obtained in a full-scale automotive spark-ignition or compression-ignition engine, or in an engine operated under conditions different from those of the test. The test can be used to compare one oil with another.

1.3 The values stated in SI units are to be regarded as standard, except for (1) volume which is given in the metric, but non-SI, litre, (2) certain tube measurements which are given in inch-pound units, (3) cylinder bore and stroke in both SI and inch-pound units (the inch-pound being the standard) and (4) piston displacement given in metric (non-SI) and inch-pound units (the inch-pound being the standard). In respect to (3) and (4) the inch-pound units are shown first and the SI units in parentheses.

1.4 *This standard does not purport to address all of the safety concerns, if any, associated with its use. It is the responsibility of the user of this standard to establish appropriate safety and health practices and determine the applicability of regulatory limitations prior to use.* Specific precautionary statements are provided throughout this test method.

1.5 This test method is arranged as follows:

Subject	Section
Introduction	
Scope	1

¹ This test method is under the jurisdiction of ASTM Committee D02 on Petroleum Products and Lubricants and is the direct responsibility of Subcommittee D02.B0 on Automotive Lubricants.

Current edition approved Nov. 1, 2005. Published December 2005. Originally approved in 2001. Last previous edition approved in 2004 as D 6709-04.

² Until the next revision of this test method, the ASTM Test Monitoring Center will update changes in this test method by means of Information Letters. Information Letters may be obtained from the ASTM Test Monitoring Center, 6555 Penn Avenue, Pittsburgh, PA 15202-4489, Attention: Administrator. This edition incorporates revisions in all Information Letters through No. 04-1.

Referenced Documents	2
Terminology	3
Summary of Test Method	4
Before Test Starts	4.1
Power Section Installation	4.2
Engine Operation (Break-in)	4.3
Engine Operation (Test/Samples)	4.4
Stripped Viscosity	4.5
Test Completion (BWL)	4.6
Significance and Use	5
Evaluation of Automotive oils	5.1
Stay in Grade Capabilities	5.2
Correlation of Results	5.3
Use	5.4
Apparatus	6
Test Engineering, Inc.	6.1
Fabricated or Specially Prepared Items	6.2
Instruments and Controls	6.3
Procurement of Parts	6.4
Reagents and Materials	7
Reagents	7.1
Cleaning Materials	7.2
Expendable Power Section-Related Items	7.3
Power Section Coolant	7.4
Reference Oils	7.5
Test Fuel	7.6
Test Oil Sample Requirements	8
Selection	8.1
Inspection	8.2
Quantity	8.3
Preparation of Apparatus	9
Test Stand Preparation	9.1
Conditioning Test Run on Power Section	9.2
General Power Section Rebuild Instructions	9.3
Reconditioning of Power Section After Each Test	9.4
Calibration	10
Power Section and Test Stand Calibration	10.1
Instrumentation Calibration	10.2
Calibration of AFR Measurement Equipment	10.3
Calibration of Torque Wrenches	10.4
Engine Operating Procedure	11
Run-In and Flush	11.1
Test Operating Conditions	11.2
Air-Fuel Ratio and Spark Advance	11.3
Air, Off-Gas and Blowby Measurement	11.4
Unscheduled Shutdowns	11.5
Oil Sampling and Oil Addition	11.6
Periodic Measurements	11.7
Final Oil Drain and Oil Consumption Computation	11.8
Operational Validity Criteria	11.9
Test Completion	11.10
Determination of Test Results	12
Oil Analysis	12.1
Test Bearing Weight Loss Determination	12.2
Report	13
Precision and Bias	14
Precision	14.1
Bias	14.2
Use of ASTM Rounding	15
Keywords	16
ANNEXES	
Measurement of Connecting Rod Bearing Clearance and Journal Taper	Annex A1
Measurement of Main Bearing Clearance	Annex A2
The ASTM Test Monitoring Center Calibration Program	Annex A3
Measurement of Piston-to-Sleeve Clearance	Annex A4
Control Chart Technique for a Laboratory's Severity Adjustment (SA)	Annex A5
Recommended New Liner Honing Procedure	Annex A6
Sequence VIII Oil Priming Procedure	Annex A7
Alternative Crankcase Breather Configuration	Annex A8
Connecting Rod Bearing Cleaning Procedure	Annex A9
Electronic Ignition Conversion	Annex A10
System Response Procedure	Annex A11
Air-Fuel Ratio Measurement	Annex A12
Lead Decontamination Procedure	Annex A13
Stay-in-Grade Oil Analysis Procedure	Annex A14
Crankshaft Rear Seal Conditioning	Annex A15

Report Forms and Data Dictionary	Annex A16
Test Fuel Specification	Annex A17

APPENDIXES

Role of the ASTM Test Monitoring Center and the Calibration Program	Appendix X1
Suggested Method for Salvaging Camshaft Bearing Journals Data Log Sheets	Appendix X2 Appendix X3

2. Referenced Documents

2.1 ASTM Standards:³

- D 86** Test Method for Distillation of Petroleum Products at Atmospheric Pressure
- D 130** Test Method for Corrosiveness to Copper from Petroleum Products by Copper Strip Test
- D 235** Specification for Mineral Spirits (Petroleum Spirits) (Hydrocarbon Dry Cleaning Solvents)
- D 240** Test Method for Heat of Combustion of Liquid Hydrocarbon Fuels by Bomb Calorimeter
- D 323** Test Method for Vapor Pressure of Petroleum Products (Reid Method)
- D 381** Test Method for Gum Content in Fuels by Jet Evaporation
- D 445** Test Method for Kinematic Viscosity of Transparent and Opaque Liquids (the Calculation of Dynamic Viscosity)
- D 525** Test Method for Oxidation Stability of Gasoline (Induction Period Method)
- D 1319** Test Method for Hydrocarbon Types in Liquid Petroleum Products by Fluorescent Indicator Adsorption
- D 2422** Classification of Industrial Fluid Lubricants by Viscosity System
- D 2699** Test Method for Research Octane Number of Spark-Ignition Engine Fuel
- D 2700** Test Method for Motor Octane Number of Spark-Ignition Engine Fuel
- D 3231** Test Method for Phosphorus in Gasoline
- D 3237** Test Method for Lead In Gasoline By Atomic Absorption Spectroscopy
- D 3343** Test Method for Estimation of Hydrogen Content of Aviation Fuels
- D 4052** Test Method for Density and Relative Density of Liquids by Digital Density Meter
- D 4294** Test Method for Sulfur in Petroleum Products by Energy-Dispersive X-Ray Fluorescence Spectroscopy
- D 4485** Specification for Performance of Engine Oils
- D 4815** Test Method for Determination of MTBE, ETBE, TAME, DIPE, tertiary-Amyl Alcohol and C1 to C4 Alcohols in Gasoline by Gas Chromatography
- D 5119** Test Method for Evaluation of Automotive Engine Oils in the CRC L-38 Spark-Ignition Engine
- D 5302** Test Method for Evaluation of Engine Oils for Inhibition of Deposit Formation and Wear in a Spark-Ignition Internal Combustion Engine Fueled with Gasoline and Operated under Low-Temperature, Light-Duty Conditions

³ For referenced ASTM standards, visit the ASTM website, www.astm.org, or contact ASTM Customer Service at service@astm.org. For *Annual Book of ASTM Standards* volume information, refer to the standard's Document Summary page on the ASTM website.

- D 5533** Test Method for Evaluation of Automotive Engine Oils in the Sequence III E, Spark-Ignition Engine
- D 5844** Test Method for Evaluation of Engine Oils for Inhibition of Rusting (Sequence IID)
- D 6202** Test Method for Automotive Engine Oils on the Fuel Economy of Passenger Cars and Light-Duty Trucks in the Sequence VIA Spark-Ignition Engine
- E 29** Practice for Using Significant Digits in Test Data to Determine Conformance with Specifications
- E 191** Specification for Apparatus For Microdetermination of Carbon and Hydrogen in Organic and Organo-Metallic Compounds
- 2.2 *SAE Standards*:⁴
 - J183, Engine Oil Performance and Engine Service Classification (Other Than “Energy-Conserving”)
 - J304, Engine Oil Tests

3. Terminology

3.1 Definitions:

- 3.1.1 *air-fuel ratio, n*—in internal combustion engines, the mass ratio of air-to-fuel in the mixture being induced into the combustion chambers. **D 6202**
- 3.1.2 *automotive, adj*—descriptive of equipment associated with self-propelled machinery, usually vehicles driven by internal combustion engines. **D 4485**
- 3.1.3 *blind reference oil, n*—a reference oil, the identity of which is unknown by the test facility.
 - 3.1.3.1 *Discussion*—This is a coded reference oil that is submitted by a source independent from the test facility. **D 5844**
 - 3.1.4 *blowby, n*—in internal combustion engines, the combustion products and unburned air-and-fuel mixture that enter the crankcase. **D 5302**
 - 3.1.5 *critical parts, n*—those components used in the test that are known to affect test severity. **D 5844**
 - 3.1.6 *noncompounded engine oil, n*—a lubricating oil having a viscosity within the range of viscosities of oils normally used in engines, and that may contain anti-foam agents or pour depressants, or both, but not other additives. **D 5119**
 - 3.1.6.1 *Discussion*—In this test method noncompounded oil is also known as build-up oil. This discussion does not appear in Test Method **D 5119**.
 - 3.1.7 *non-standard test, n*—a test that is not conducted in conformance with the requirements in the standard test method; such as running on an uncalibrated test stand, using different test equipment, applying different equipment assembly procedures, or using modified operating conditions. **D 5844**
 - 3.1.8 *test start, n*—introduction of test oil into the engine. **D 5333**
 - 3.1.9 *wear, n*—the loss or relocation of material from a surface.
 - 3.1.9.1 *Discussion*—Wear generally occurs between two surfaces moving relative to each other, and is the result of

mechanical or chemical action or by a combination of mechanical and chemical actions. **D 5302**

3.2 Definitions of Terms Specific to This Standard:

- 3.2.1 *accessory case, n*—the mounting base containing the balancing mechanism, flywheel, and final driveshaft for the power section of the CLR engine.
 - 3.2.1.1 *Discussion*—This definition was modified to embrace the CLR engine. The definition in Test Method **D 5119** embraces the L-38 engine.
 - 3.2.2 *build-up oil, n*—see 3.1.6, noncompounded engine oil.
 - 3.2.3 *calibrated power section/test stand combination, n*—one that has completed an operationally valid reference oil test within the previous six months, the results of which fall within industry severity and precision limits as published by the TMC.
 - 3.2.4 *conditioning test run, n*—a full-length Sequence VIII test using a TMC-designated reference oil in a new or newly rebuilt power section to prepare the cast iron parts before conducting routine standard tests with the power section.
 - 3.2.5 *emergency shutdown, n*—the procedure for turning off the engine’s ignition without using the prescribed engine cool-down period.
 - 3.2.6 *full-length test, n*—a test of an engine oil conducted using a power section and a test stand that runs 4½-h run-in, 2-h flush and 40 h at test conditions. (See 10.1.3.1, exception for 10-h stay in grade test).
 - 3.2.7 *new power section, n*—an engine power section consisting of either a new crankcase or complete power section that has no previous oil test history.
 - 3.2.8 *off-gas, n*—gas exiting the power section crankcase breather.
 - 3.2.9 *off-test time, n*—any time that the engine is not operating at the prescribed test conditions.
 - 3.2.10 *oil gallery side cover plate, n*—crankcase cover plate that contains the oil gallery and provision for mounting and driving the oil pump and ignition assembly.
 - 3.2.11 *operationally valid test, n*—an engine oil test that has been conducted in accordance with the conditions listed in this test method.
 - 3.2.12 *power section, n*—the combination of the crankcase assembly, the cylinder block assembly, and the cylinder head assembly, all of which are attached to the accessory case.
 - 3.2.13 *reconditioned power section, n*—an engine power section which has been disassembled, cleaned, and reassembled according to the detailed procedures⁵ after completion of either a conditioning test run or a full-length CLR engine oil test.
 - 3.2.14 *reference oil test, n*—a standard Sequence VIII engine oil test of a reference oil designated by the TMC, conducted to ensure that power section and test stand severity falls within industry limits.
 - 3.2.15 *run-in and flush, n*—the initial 4½-h operation of a new, rebuilt, or reconditioned power section at the beginning of either a conditioning test run or a full-length test.

⁴ Available from Society of Automotive Engineers, Inc., 400 Commonwealth Drive, Warrendale, PA 15096. Request SAE Handbook Vol 3. This standard is not available separately.

⁵ Refer to Instructions for Assembly and Disassembly of the CLR Oil Test Engine, available from Test Engineering, Inc., 12718 Cimarron Path, San Antonio, TX 78249.

TABLE 1 Power Section Run-in Schedule

Speed, r/min (±25)	Load		Spark Advance, ° BTDC (±1)	Time, min (±2)	Total Time, h
	bhp (±0.2)	(w) (±150)			
1500	2.0	(1500)	25	60	1
2000	4.0	(3000)	25	60	2
2500	5.0	(3700)	35	60	3
3150	5.0	(3700)	35	60	4

3.2.16 *scheduled downtime, n*—off-test time that is specifically allowed to include warm-up and cool-down periods as well as shutdown and intermediate bearing weight loss measurements.

3.2.17 *shutdown, n*—the procedure for turning off the engine’s ignition following the prescribed engine cool-down period.

3.2.18 *standard test, n*—an operationally valid, full-length Sequence VIII test conducted with a calibrated power section and test stand in accordance with the conditions listed in this test method.

3.2.19 *stay-in-grade (stripped viscosity), n*—the viscosity of the test oil after removal of volatile components and solids, according to the procedure shown in [Annex A14](#).

3.2.20 *test oil, n*—an oil subjected to a Sequence VIII engine oil test.

3.2.20.1 *Discussion*—It can be any oil selected by the laboratory conducting the test. It could be an experimental oil or a commercially available oil. Often, it is an oil that is a candidate for approval against engine oil specifications.

3.2.21 *test stand, n*—the engine accessory case connected to a dynamometer, both mounted to a suitable foundation (such as a bedplate) and equipped with suitable supplies of electricity, compressed air, and so forth, to provide a means for mounting and operating a power section in order to conduct a Sequence VIII engine oil test.

3.3 Acronyms:

3.3.1 *BTDC, adj*—before top dead center

3.3.1.1 *Discussion*—It is used with the degree symbol to indicate the angular position of the crankshaft from its position at the point of uppermost travel of the piston in the cylinder.

3.3.2 *EWMA, n*—exponentially-weighted moving average

3.3.3 *LTMS, n*—Lubricant Test Monitoring System

3.3.3.1 *Discussion*—An analytical system in which ASTM calibration test data are used to manage lubricant engine test precision.

3.3.4 *SIG, adj*—stay-in-grade

3.3.4.1 *Discussion*—Capability of multiviscosity-graded oil to stay in grade under test conditions (see [4.5](#)).

3.3.5 *TDC, adj*—top dead center

3.3.5.1 *Discussion*—It is used with the degree symbol to indicate the angular position of the crankshaft from its position at the point of uppermost travel of the piston in the cylinder.

4. Summary of Test Method

4.1 Before every Sequence VIII engine oil test, thoroughly clean the power section of the CLR oil test engine, and measure the power section parts. Install a new or clean used piston, a complete set of new piston rings, a set of new

copper-lead connecting rod test bearing inserts (from a batch approved by the ASTM D02.B0.01 Sequence VIII Test Surveillance Panel), and other specified parts as required.

4.2 The power section is installed on an accessory case/test stand. Unleaded fuel is used for the test.

4.3 The engine is first operated for 4 h according to a run-in schedule shown in [Table 1](#) (see [11.1](#)).

4.4 The engine is then operated for 40 h under specified conditions ([Table 2](#)). At the end of each 10-h of test conditions, a sample of the test oil is drained from the power section and fresh oil is returned to the power section for continuation of the test.

4.5 An oil sample is taken at the end of the first 10-h of test conditions. When multiviscosity-graded oils are being tested, this sample is used to determine the stay-in-grade (SIG) capabilities of the test oil.

4.6 At the completion of the test, the connecting rod bearing weight loss is determined.

5. Significance and Use

5.1 This test method is used to evaluate automotive engine oils for protection of engines against bearing weight loss.

5.2 This test method is also used to evaluate the SIG capabilities of multiviscosity-graded oils.

5.3 Correlation of test results with those obtained in automotive service has not been established.

5.4 *Use*—The Sequence VIII test method is useful for engine oil specification acceptance. It is used in specifications and classifications of engine lubricating oils, such as the following:

5.4.1 Specification [D 4485](#).

5.4.2 API Publication 1509 Engine Oil Licensing and Certification System.⁶

5.4.3 SAE Classification J304.

6. Apparatus

6.1 *Test Engineering, Inc.*—The document “Instructions for Assembly and Disassembly of the CLR Test Engine”⁵ provides detailed parts listings, modification instructions, assembly/disassembly instructions, maintenance procedures, and parts replacement requirements. The following is a descriptive listing of some of the test engine and associated parts.

6.1.1 *Test Engine*—Obtain the test engine from Test Engineering Inc. (TEI).⁵ The test engine is known by various designations such as the L-38 engine, the CLR engine, or the

⁶ American Petroleum Institute, 1220 L Street, NW, Washington, DC 20005.

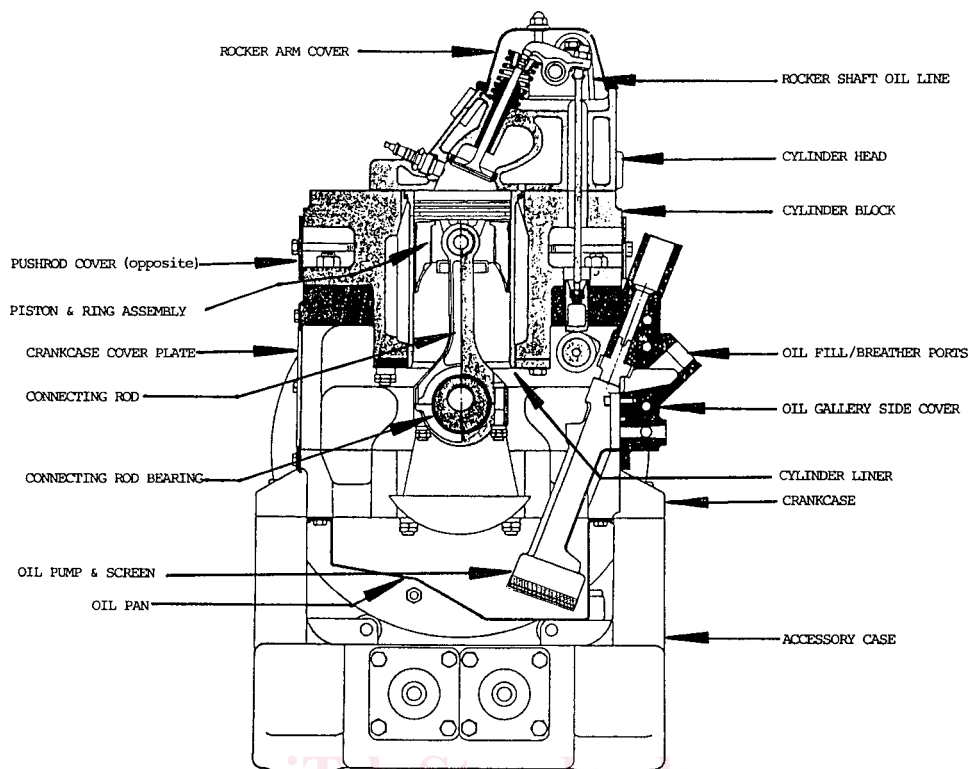

FIG. 1 Sequence VIII Power Section

TABLE 2 Test Operating Conditions

Item	Setting
Speed, r/min	3150 ± 25
Load bhp	Adjust load to provide proper fuel flow at specified air-fuel ratio.
Fuel flow, kg/h (lb/h)	2.25 ± 0.11 (4.96 ± 0.25)
Air-fuel ratio	13.43 ± 0.5
Jacket outlet coolant Temperature, °C (°F)	93.5 ± 1 (200 ± 2)
Difference between jacket Inlet and jacket outlet Coolant temperatures, °C (°F)	5.6 ± 1 (10 ± 2)
Gallery oil temperature, °C (°F)	
SAE 5W, 10W	135 ± 1 (275 ± 2)
SAE 20, 30, 40, 50, and multiviscosity-graded oils	143.5 ± 1 (290 ± 2)
Spark advance, °BTDC	35 ± 1
Oil pressure, kPa (psi)	276 ± 14 (40 ± 2)
Crankcase vacuum, Pa (in. H ₂ O)	500 ± 120 (2 ± 0.5)
Exhaust back pressure, Pa (in. Hg)	0 to 3.4 (0 to 1)
Crankcase off-gas, SLH	850 ± 28
Blowby, SLH	record

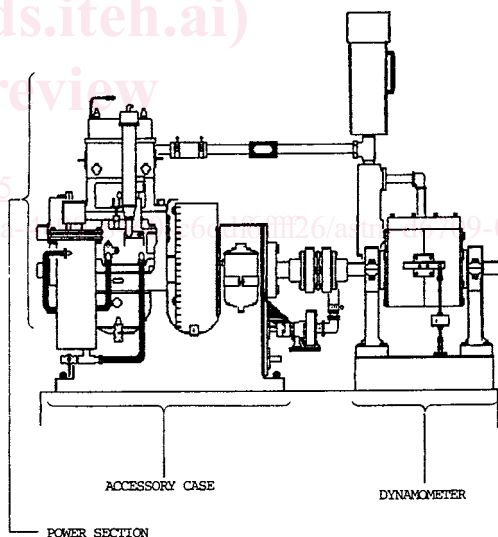

FIG. 2 Typical Sequence VIII Engine Test Stand

Sequence VIII engine (as used in this test method). It comprises two principal units, the power section and the accessory case (Fig. 1). The power section is a single-cylinder, spark-ignition unit with 96.5-mm (3.80-in.) bore and 95.2-mm (3.75-in.) stroke, displacing 0.696 L (42.5 in.³).

6.1.2 *Test Bearing*—SAE H-24 alloy connecting rod bearing, TEI Part No. 100034-1, from a batch approved by the ASTM Sequence VIII Test Surveillance Panel.

6.1.3 *Test Engine Crankshaft*—Obtain a crankshaft for the CLR test engine, Part No. 100039-1, from TEI. If desired, the crankshaft may be refinished in one of the following two manners:

6.1.3.1 The oil seal and main bearing journals may be refinished by welding material to the journals and regrinding the journals to the original specifications. The connecting rod journal shall not be refinished using this test method.

6.1.3.2 The crankshaft may be refinished by chrome plating^{7,8} the oil seal, connecting rod journal, and main bearing

⁷ The sole source of supply of crankshaft refinishing by chrome plating known to the committee at this time is OH Technologies, Inc., P.O. Box 5039, Mentor, OH, 44061-5039.

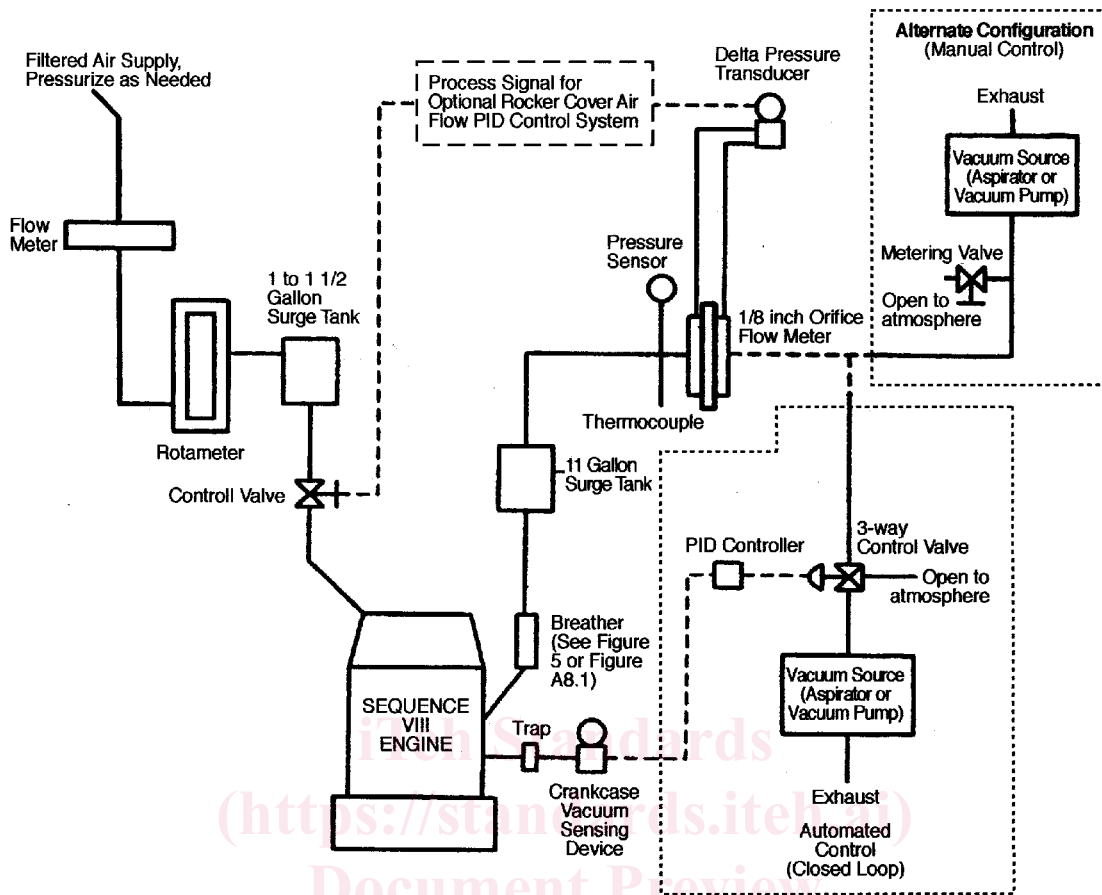

FIG. 3 Standard Crankcase Ventilation System for the Sequence VIII Power Section

journals. When refinishing a crankshaft using this test method, all journals listed shall be chrome plated.

6.1.3.3 To identify the crankshaft being used in a power section the following identification is required:

- (1) S = standard crankshaft,
- (2) C = chrome crankshaft, and
- (3) R = reconditioned crankshaft.

6.1.4 *Test Engine Piston*—Obtain a piston for the CLR test engine, TEI Part No. 2405, from TEI. If desired, a piston may be reused if it meets the piston-to-liner clearance specifications. A 0.010-in. oversized piston, TEI Part No. 2405-1, may also be used in the Sequence VIII test, provided it meets the piston-to-liner clearance specifications. Do not reuse pistons used in the CLR test engine for L-38 testing or any other testing with leaded fuel in Sequence VIII testing. Clean used pistons according to the following procedure before installation in the test engine.

6.1.4.1 Clean the piston crown of any carbon deposits using aliphatic naphtha and 3M fine-grade Scotch Brite pads. Wet the cleaning pad in the solvent and scrub the deposit. Repeat until all carbon is removed.

6.1.4.2 Spray piston with clean solvent and air dry.

6.1.5 *Piston Ring Assembly*—Use a Dana/Perfect Circle piston ring assembly, Part No. 41274, in the Sequence VIII test engine.^{8,9}

6.2 *Fabricated or Specially Prepared Items:*

6.2.1 A typical Sequence VIII engine test stand configuration is shown in Fig. 2.

6.2.2 *Crankcase Ventilation System*—Fig. 3 is a schematic of the required configuration of the crankcase ventilation measurement and control system.

6.2.2.1 Fabricate the airtight rocker cover air and off-gas condensate trap/surge tanks shown in Fig. 3, with provisions for draining and cleaning. The volume of the rocker cover air tank shall be 3.8 to 5.7 L (1 to 1.5 gal). The volume of the off-gas tank shall be 38 to 45 L (10 to 12 gal). Fabricate both tanks from noncorrosive material. Locate the tanks as shown in Fig. 3.

6.2.2.2 *Rocker Cover Air Flow*—Measure the air flow into the rocker cover by using a Sierra Side Track Model 830 flow

⁸ If you are aware of alternative suppliers, please provide this information to ASTM International Headquarters. Your comments will receive careful consideration at a meeting of the responsible technical committee,¹ which you may attend.

⁹ The sole source of supply of the Dana/Perfect Circle piston ring assembly Part No. 41274 known to the committee at this time is Dana Corp., Perfect Circle Division, 1883 E. Laketon Ave., Product Distribution Center, Muskegon, MI 49442-6123.

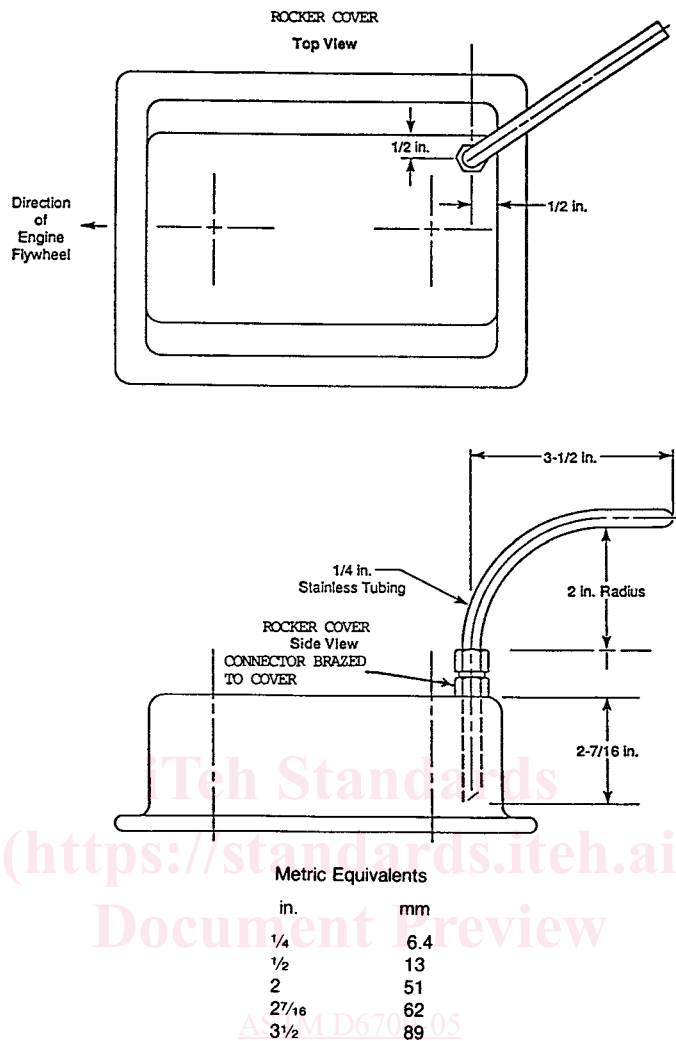

FIG. 4 Rocker Cover Air Inlet Detail

meter^{8,10} capable of measuring 0 to 20 L/min. An optional Dwyer rotameter, Model No. RMC-101,^{8,11} with a range of 0 to 1420 L/h may be used for ease of adjustments; however, actual measurements shall be taken with the Sierra flow meter. All piping and tubing used to flow air into the rocker cover shall be nominal 3/8-in. I.D.

6.2.2.3 When a closed loop automated control system is employed, use a Badger meter research control valve, Model No. 1002-GCN36-SVCSC-LN36,^{8,12} (see **Note 1**) to control the rocker cover air flow. When using a manual control system instead of the automated system, install a Swagelok 3/8-in. metering valve, Part No. SS-6L,¹³ to control the air flow into the rocker cover.

¹⁰ The sole source of supply of Sierra Side Track flow meters known to the committee at this time is Sierra Instruments Inc., 5 Harris Ct, Building L, Monterey, CA 93940.

¹¹ The sole source of supply of Dwyer instrumentation known to the committee at this time is Dwyer Instruments Inc., P.O. Box 60725, Houston, TX 77205.

¹² The sole source of supply of Badger valves known to the committee at this time is Badger Meter Industrial Div., 6116 East 15th St., P.O. Box 581390, Tulsa, OK 74158-1390.

¹³ Except for the stainless steel wool and screens, parts for the construction of the crankcase breather may be obtained from many commercial sources. The part numbers given identify the components available from McMaster Carr, Chicago, IL.

NOTE 1—The letter prior to the last dash in the model number defines the trim size. Use the trim that gives the best system control.

6.2.2.4 **Fig. 4** shows the details of the rocker cover inlet for the crankcase ventilation air. Braze one half of a 1/8-in. (3.2-mm) connector with the beveled end facing the near corner of the rocker cover. Tighten the connector nut securely.

6.2.2.5 Construct the off-gas breather¹³ as shown in **Fig. 5** using American Standard Schedule 40, or equivalent, non-galvanized pipe fittings. Apply sealant to the threads during assembly. Install the breather in the breather port of the oil gallery side cover (see **Fig. 6**) of the engine power section. **Fig. A8.1** shows freeze plug detail in an alternative configuration to that in **Fig. 5**.

6.2.2.6 *Crankcase Off-Gas Flow*—Measure the crankcase off-gas flow by using a Daniels Honed Orifice Flange Flow Section, Model No. H1905T-1/2 in.,^{8,14} with orifice plate, F-150-1/8 in., and a Rosemount differential pressure transducer,

¹⁴ The sole source of supply of Daniels flow sections known to the committee at this time is Daniel Flow Products Inc., Flow Measurement Products Div., P.O. Box 19097, Houston, TX 77224.

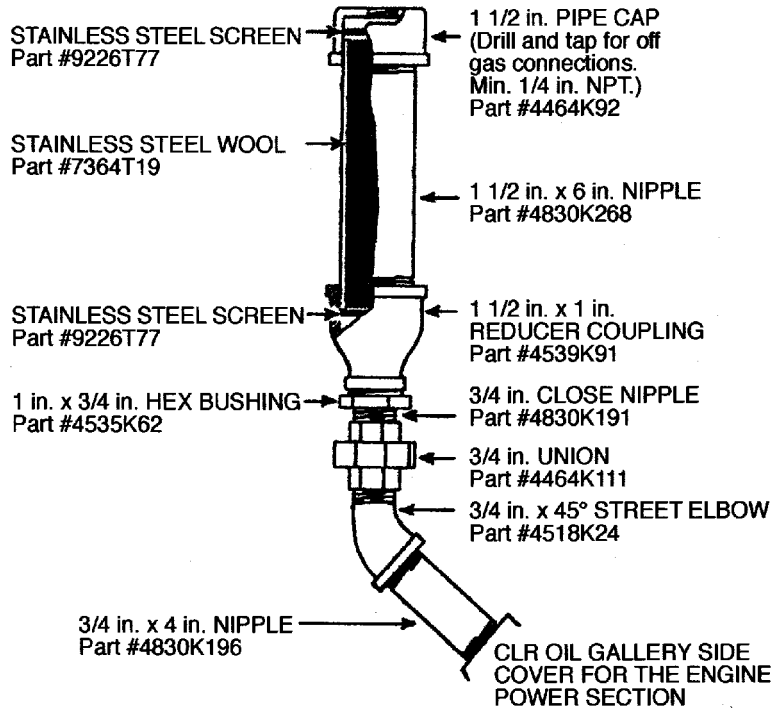

FIG. 5 Crankcase Breather Detail

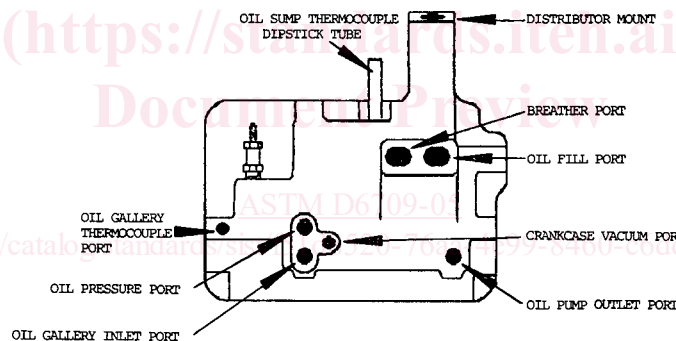

FIG. 6 Oil Gallery Side Cover

Model No. 1151DP-3-S-22-D1B2.^{8,15} Mount the flow section horizontally. The transducer may be set up as square root extracting to aid in interfacing with the readout. Locate temperature and pressure measurement devices at the inlet of the off-gas measurement apparatus as shown in Fig. 3.

6.2.2.7 When a closed loop automated control system is employed, use a Badger meter research control valve, Model No. 1002-TCN36-SVCSA-LN36, to control the crankcase vacuum. When using a manual control system instead of the automated control system, install a Swagelok $\frac{3}{8}$ -in. metering valve, Part No. SS-6L, to control the crankcase vacuum. Both systems are shown in Fig. 3.

6.2.2.8 Use a Vaccom vacuum aspirator, Model No. JD-90M,^{8,16} or a vacuum pump as a vacuum source.

6.2.2.9 *Rocker Cover Air Inlet Pressure*—Use a Dwyer Magnehelic, Model No. 2320, or a Sensotech pressure transducer, Model No. TJE-756-05,^{8,17} to measure the rocker cover air pressure. Convert the measured value to kPa for use in off-gas measurement calculation (see 11.4.1) Locate the sensor at the inlet of the rocker cover air flow apparatus as shown in Fig. 3.

6.2.2.10 *Crankcase Off-Gas Inlet Pressure*—Use a Dwyer Magnehelic, Model No. 2320, or a Sensotech pressure transducer, Model No. TJE-756-05, to measure the off-gas air

¹⁵ The sole source of supply of Rosemount transducers known to the committee at this time is Rosemount Inc., 4001 Greenbriar, Ste 150B, Stafford, TX 77477.

¹⁶ The sole source of supply of Vaccom aspirators known to the committee at this time is McKenzie Air Industries, 18523 IH 35 North, Shertz, TX 78108.

¹⁷ The sole source of supply of Sensotech transducers known to the committee at this time is Sensotech Inc., 1200 Chesapeake Ave., Columbus, OH 43212.

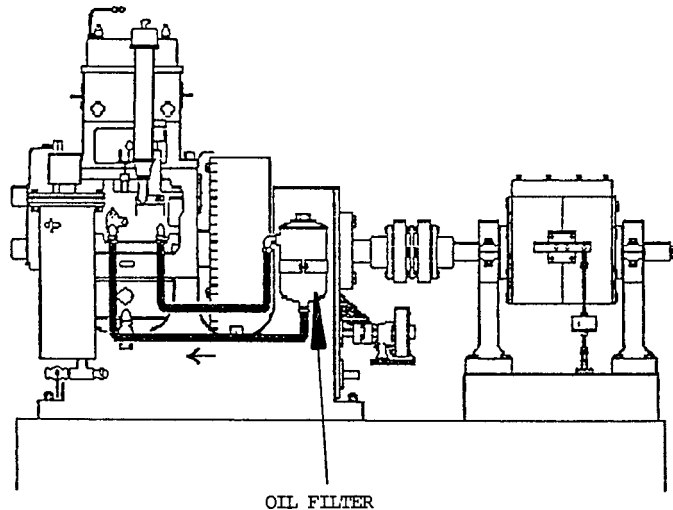

FIG. 7 Oil Filter Installation

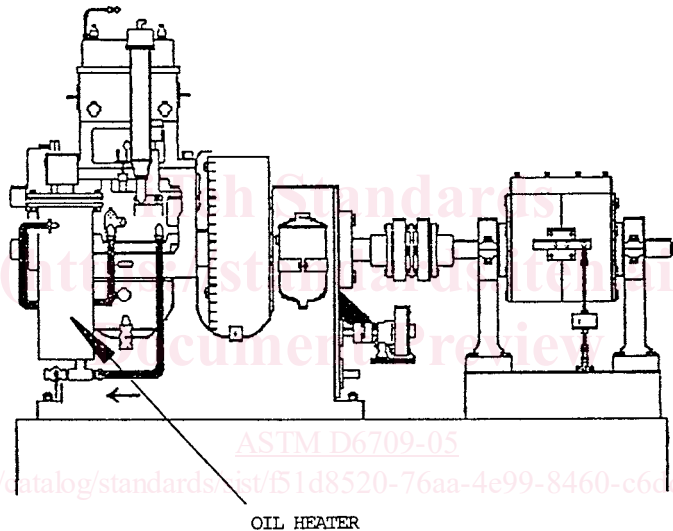

FIG. 8 Oil Heater Installation

pressure. Locate the sensor at the inlet of the off-gas air flow apparatus as shown in Fig. 3.

6.2.2.11 *Rocker Cover Air Inlet Temperature*—Measure the rocker cover inlet air temperature with a 1/8-in. J-type thermocouple. Position the thermocouple tip in the middle of the air stream and expose no more than 50 mm of the sheath to ambient air. Locate the thermocouple at the inlet of the rocker cover air measurement apparatus as shown in Fig. 3.

6.2.2.12 *Crankcase Off-Gas Inlet Temperature*—Measure the off-gas temperature with a 1/8-in. J-type thermocouple. Position the thermocouple tip in the middle of the air stream and expose no more than 50 mm of the sheath to ambient air. Locate the thermocouple at the inlet of the off-gas flow measurement apparatus as shown in Fig. 3.

6.2.3 *Oil Filter*—Install a Racor, Model LFS-62,¹⁸ the specified oil filter as shown in Fig. 7. Use suitable hydraulic hose and fittings.¹⁹

6.2.3.1 *Oil Drain Valves*—Locate oil drain valves at points no higher than the bottom of the oil pan or the vertically mounted oil heater.

6.2.4 *Oil Heater*—Install the oil heater as shown in Fig. 8. Use suitable hydraulic hose and fittings.¹⁹

6.2.5 *Power Section Cooling System*—Install a non-pressurized cooling system consisting of a heat exchanger, water pump, coolant throttling valve, sight glass, and tower

¹⁸ The sole source of supply of the oil filter known to the committee at this time is Parker Hanifin Corp., Racor Division, 3400 Finch Road, Modesto, CA 95350.

¹⁹ Aeroquip 3/8-in. (10-mm) (inside diameter) hydraulic hose has been used successfully to plumb the oil filter and oil heater; select hose of a specification to cover temperatures and pressures encountered in Sequence VIII engine oil testing.

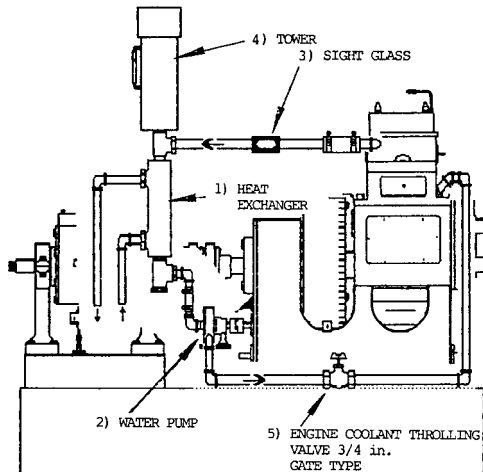

FIG. 9 Cooling System

(see Fig. 9). Use American Standard Schedule 40, or equivalent, 3/4-in. non-galvanized pipe fittings and apply sealant to the threads during assembly.

6.2.5.1 Use a water-cooled heat exchanger. A heat exchanger of this type, suitable for this application, is available as American Heat Exchanger, Part Number 5-030-03014-011.^{8,20}

6.2.5.2 Install a 3/4-in. gate-type coolant throttling valve on the output side of the coolant pump to maintain the specified temperature differential between the coolant flowing into, and that flowing out of, the power section jacket.

6.2.5.3 The coolant pump is to be an electrically driven centrifugal pump with a flow of approximately 18.9 L/min at 95.5 kPa of water head pressure. The Grainger²¹ Part No. 1P831 has been found suitable.

6.2.5.4 Install a sight glass^{8,22} located downstream of the cylinder head to permit detection of air entrainment.

6.2.5.5 Fabricate the tower using non-galvanized metal. Make it approximately 90 mm in diameter and 410 mm long. Fashion a loose-fitting cover for it. Install a level gage, positioned to give a mid-scale reading when the system is filled. The system shall have a minimum capacity of 7.5 L.

6.2.6 *Exhaust System*—Use either a water-quenched system or a dry system.

6.2.7 *Ignition System*—An electronic ignition system is required. The required system is illustrated in Figs. A10.1-A10.10. Other electronic ignition system configurations shall be reviewed and approved by the TMC and the Sequence VIII Surveillance Panel, prior to use.

6.3 Instruments and Controls:

6.3.1 *Dynamometer*—Use a dynamometer and control system capable of maintaining the specified engine operating test conditions (see Section 11). Speed measurement shall have a minimum accuracy of $\pm 0.5\%$ of reading, and load minimum measurement accuracy of $\pm 2\%$ of reading.

6.3.2 *Fuel Flowmeter or Fuel Weigh System*—Use a system with a range of 0 to 4.5 kg/h, and having a minimum accuracy of 1 % reading and 0.5 % repeatability.

6.3.3 *Air-Fuel Ratio Measurement System*—Use a system with a calibration capability of the equivalent of ± 0.5 air-fuel ratio number. The following are acceptable methods for determination of air-fuel ratio:

6.3.3.1 *Calibrated Electronic Exhaust Gas Analyzer*—Use sample gases for the calibration. Follow the directions in Annex A12 to determine air-fuel ratio.

6.3.3.2 *AFR Analyzer/Lambda Meter*—The air fuel ratio (AFR) analyzer shall have a measurement range of 11.00 to 18.00 for AFR with 1.85 H/C and 0.00 O/C, where: H is hydrogen, C is carbon and O is oxygen.

6.3.3.3 When a Lambda meter is used, the exhaust sensor location is to be within 150 ± 50 mm of the cylinder head exhaust outlet mating surface.

6.3.4 Pressure Measurement:

6.3.4.1 *Crankcase Vacuum*—As shown in Fig. 3, connect a line trap and an appropriate sensor to the crankcase at the hole above and to the right of the oil heater inlet hose connection on the oil gallery side cover. See Fig. 6 for the location of the crankcase vacuum port. Measurement resolution of 50 Pa and 1 % accuracy in the specified range of $.500 \pm .120$ kPa are required.

6.3.4.2 *Exhaust Back Pressure*—Connect an appropriate sensor to the exhaust back-pressure tap at a point within 100 mm of the cylinder head exhaust flange. Sensor accuracy of $\pm 10\%$ of reading and resolution of 340 Pa are required.

6.3.4.3 *Intake Manifold Vacuum*—Measure the intake manifold vacuum at the elbow of the intake manifold by means of a sensor having an accuracy of 1 % and a resolution of 680 Pa.

6.3.4.4 *Oil Pressure*—Measure the oil pressure with an appropriate sensor having an accuracy of $\pm 2\%$ and a resolution of 7 kPa, connected to the point shown in Fig. 6.

6.3.5 *Temperature Measurement*—The test requires the accurate measurement of oil and coolant temperature. Exercise care to ensure temperature measurement accuracy. Follow the guidelines of Research Report RR:D02-1218.²³

6.3.5.1 Check all temperature devices for accuracy at the temperature levels at which they are to be used. Iron-Constantin (Type J) thermocouples are specified for temperature measurement.

6.3.5.2 All thermocouples shall be premium grade, sheathed types with premium wire. Use thermocouples of 3.2 mm diameter. Thermocouple lengths are not specified but shall not have greater than 5 cm of thermocouple sheath exposed to ambient laboratory temperature.

6.3.5.3 Some sources of thermocouples that have been found suitable for this application are, Leeds and Northrup, Conax, Omega, Revere, and Thermo Sensor.

6.3.5.4 System quality shall be adequate to permit calibration to ± 0.56 °C for individual thermocouples.

²⁰ The sole source of supply of the heat exchanger known to the committee at this time is Compressor Engineering, 625 District Dr., Itasca, IL 60143.

²¹ Any Grainger national branch location.

²² The sole source of supply of a sight glass of this type, suitable for this application (Gitts-Part No. 3063-27) known to the committee at this time is Edward Fisher Co., 118 S. Wabash, Chicago, IL 60616.

²³ Supporting data have been filed at ASTM International Headquarters and may be obtained by requesting Research Report RR: D02-1218.

6.3.6 *Thermocouple Location and Length*—All thermocouple tips shall be located in the center of the stream of the medium being measured unless otherwise specified.

6.3.6.1 *Coolant Temperatures*—The thermocouples used to measure the coolant inlet and outlet temperatures are to be located within 100 mm of the inlet and outlet bosses on the power section.

6.3.6.2 *Air Inlet Temperature*—Measure the air inlet temperature with an exposed thermocouple or thermometer located at the center of the air tube, 38 mm above the carburetor air horn.

6.3.6.3 *Oil Gallery Temperature*—Measure oil gallery temperature at the front main bearing passage (see Fig. 6). The immersion length for these thermocouples is 35 mm.

6.3.6.4 *Crankcase Off-Gas Temperature Measurement*—Measure the off-gas temperature at the outlet side of the crankcase breather assembly. Fig. 3 shows a recommended system.

6.4 *Procurement of Parts*—Obtain information on the CLR Oil Test Engine (see 6.1.1) and parts for it from TEI. Users of this test method shall comply with CLR Oil Test Engine Shop Manual⁵ and the latest supplements (Information Letters and Memoranda) available from the TMC.

7. Reagents and Materials

7.1 Reagents:

7.1.1 A 1:3 mixture of hydrochloric acid and deionized water. (**Warning**—The laboratory shall establish proper safety procedures for handling and disposal of this reagent.)

7.1.2 A 1:8 mixture of baking soda and water. (**Warning**—The laboratory shall establish proper safety procedures for handling and disposal of this reagent.)

7.2 Cleaning Materials:

7.2.1 *Abrasive Paper*,²⁴ 400-, 600-, 800-grit, wet or dry.

7.2.2 *Crocus Cloth*.²⁴

7.2.3 *Mylar Tape*.²⁴

7.2.4 *Organic Solvent-Penmul L460*^{8,25} (**Warning**—Combustible. Health hazard.).

7.2.5 *Pentane (Solvent)*, 99 + %, high-performance liquid chromatography grade (**Warning**—Flammable. Health hazard.).

7.2.6 *Solvent*—Use only mineral spirits meeting the requirements of Specification D 235, Type II, Class C for Aromatic Content (0-2% vol), Flash Point (142°F/61°C, min) and Color (not darker than +25 on Saybolt Scale or 25 on Pt-Co Scale). (**Warning**—Combustible. Health hazard.) Obtain a Certificate of Analysis for each batch of solvent from the supplier.

7.2.7 *Tap Water*, heated to between 66 and 82°C.

7.3 Expendable Power Section-Related Items:

7.3.1 *Sealing Compounds*—Approved sealing compounds, including pipe thread compound and gasket cement are:

7.3.1.1 *Perfect Seal Sealant No. 4*.²⁶

7.3.1.2 *Permatex Ultra Blue 77B*.²⁶

7.3.1.3 *Permatex 3H, Permatex High Tack 99 MA*.²⁶

7.3.1.4 *Dow Corning High Vacuum Grease*.²⁶

7.3.1.5 *Dow Corning RTV Gray 3154*, and²⁶

7.3.1.6 *Petroleum Jelly*.²⁶

7.3.2 *Power Section Build-Up Oil*.²⁷

7.4 *Power Section Coolant*—Use deionized or distilled water for the power section coolant, plus a suitable inhibitor such as Pencool 2000^{8,28} at 31 mL of Pencool 2000/L. Such water purchased from a commercial source is suitable.

7.5 *Reference Oils*—Conduct test periodically on reference oils supplied by the TMC, to document the test severity of a given power section and test stand, and the overall operation of the test. Use 8 L (2 gal.) of reference oil for each test.

7.6 *Test Fuel*—Use Haltermann Products KA24E Test Fuel.^{8,29} See Annex A17 for the specification for KA24E Test Fuel. (**Warning**—Flammable. Health hazard.)

7.6.1 *Fuel Batch Approval*—New batches of KA24E Test Fuel are approved for use by the Subcommittee D02.B0.01 Sequence IVA Surveillance Panel.³⁰

7.6.2 *Fuel Batch Analysis*—Details are available from Subcommittee D02.B0.01 Sequence IVA Surveillance Panel.

7.6.3 *Laboratory Storage Tank Fuel Analysis*—Details are available from Subcommittee D02.B0.01 Sequence IVA Surveillance Panel.

7.6.4 *Fuel Batch Shipment and Storage*—Details are available from Subcommittee D02.B0.01 Sequence IVA Surveillance Panel.

8. Test Oil Sample Requirements

8.1 *Selection*—The sample of test oil shall be representative of the lubricant formulation being evaluated and shall be uncontaminated.

8.2 *Inspection*—New oil sample baseline inspection requirements are described in 12.1.1.

8.3 *Quantity*—Approximately 7 L of fresh oil is required to complete the test. It is recommended that a test laboratory have approximately 8 L of oil on hand when starting a test to allow for inadvertent losses.

9. Preparation of Apparatus

9.1 Test Stand Preparation:

9.1.1 *Instrumentation Calibration*—Check the calibration of temperature sensors, flowmeters, pressure sensors, and dynamometer load indicator as required by the type of instrumentation being used. Details on calibration, of both power section and test stand, and of instrumentation, are given in 10.2.

²⁷ Noncompounded oil ISO VG 46 (SAE 20) (see Classification D 2422) is available through lubricant marketers. One supplier is Exxon-Mobil Oil Corp. The Exxon-Mobil product is designated EF-411, and is available from Exxon-Mobil Oil Corp., P.O. Box 66940, AMF O'Hare, IL 60666, Attn: Illinois Order Board.

²⁸ The sole source of supply of Pencool 2000 known to the committee at this time is The Penray Co, Inc., 1801 Estes Ave., Elk Grove, IL 60007.

²⁹ The sole source of supply of Haltermann Products KA24E Test Fuel known to the committee at this time is Haltermann Products, Ten Lamar, Ste 1800, Houston, TX 77002.

³⁰ Contact the TMC for address information for the D02.B0.01 Sequence IVA Surveillance Panel.

²⁴ The sand paper and Mylar tape may be obtained from many commercial sources.

²⁵ The sole source of supply of Penmul L460, a registered trademark, known to the committee at this time is Penetone Corp., 7400 Hudson Ave., Tenafly, NJ 07670.

²⁶ These may be obtained from many commercial sources.