

INTERNATIONAL STANDARD

ISO
406

Second edition
1987-10-01



INTERNATIONAL ORGANIZATION FOR STANDARDIZATION
ORGANISATION INTERNATIONALE DE NORMALISATION
МЕЖДУНАРОДНАЯ ОРГАНИЗАЦИЯ ПО СТАНДАРТИЗАЦИИ

Technical drawings — Tolerancing of linear and angular dimensions

Dessins techniques — Tolérancement de dimensions linéaires et angulaires

STANDARD PREVIEW

(standards.iteh.ai)

ISO 406:1987

<https://standards.iteh.ai/catalog/standards/sist/9b923959-3164-479e-b43a-5d24292cf4f3/iso-406-1987>

Reference number
ISO 406: 1987 (E)

Foreword

ISO (the International Organization for Standardization) is a worldwide federation of national standards bodies (ISO member bodies). The work of preparing International Standards is normally carried out through ISO technical committees. Each member body interested in a subject for which a technical committee has been established has the right to be represented on that committee. International organizations, governmental and non-governmental, in liaison with ISO, also take part in the work.

Draft International Standards adopted by the technical committees are circulated to the member bodies for approval before their acceptance as International Standards by the ISO Council. They are approved in accordance with ISO procedures requiring at least 75 % approval by the member bodies voting.

International Standard ISO 406 was prepared by Technical Committee ISO/TC 10, *Technical drawings*.

This second edition cancels and replaces the first edition (ISO 406:1982), of which it constitutes a technical revision. <https://standards.iteh.ai/catalog/standards/sist/9b923959-3164-479e-b43a-5d24292cf4f3/iso-406-1987>

Users should note that all International Standards undergo revision from time to time and that any reference made herein to any other International Standard implies its latest edition, unless otherwise stated.

Technical drawings — Tolerancing of linear and angular dimensions

iTeh STANDARD PREVIEW
(standards.iteh.ai)

0 Introduction

For the purposes of this International Standard, all dimensions and tolerances on the drawings have been stencilled in upright lettering. It should be understood that these indications could just as well be written in free-hand or inclined (italic) lettering without altering the meaning of the indications.

For the presentation of lettering (proportions and dimensions), see ISO 3098-1.

1 Scope and field of application

This International Standard specifies the indication of tolerances for linear and angular dimensions on technical drawings. Indicating such tolerances does not necessarily imply the use of any particular method of production, measurement or gauging.

2 References

ISO 129, *Technical drawings — Dimensioning — General principles, definitions, methods of execution and special indications*.

ISO 3098-1, *Technical drawings — Lettering — Part 1: Currently used characters*.

3 Units

Deviations shall be expressed in the same unit as the basic size.

If two deviations relating to the same dimension have to be shown, both shall be expressed to the same number of decimal places (see figure 2), except if one of the deviations is zero (see figure 5).

4 Indication of the components of a linear dimension

4.1 ISO symbols

The components of the toleranced dimension shall be indicated in the following order:

- the basic size;
- the tolerance symbol.

If, in addition to the symbols (see figure 1), it is necessary to express the values of the deviations (see figure 2) or the limits of size (see figure 3), the additional information shall be shown in parentheses.

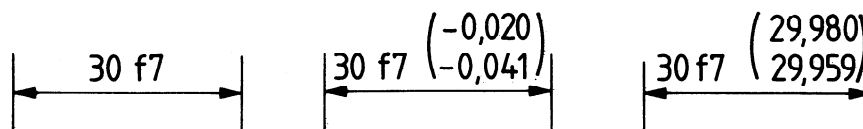

Figure 1

Figure 2

Figure 3

4.2 Permissible deviations

The components of the tolerated dimension shall be indicated in the following order (see figures 4 to 6):

- a) the basic size;
- b) the values of the deviations.

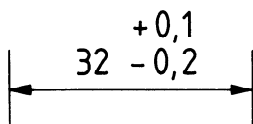

Figure 4

If one of the two deviations is zero, this should be expressed by the digit zero (see figure 5).

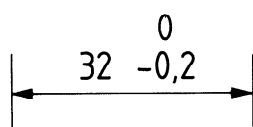

Figure 5

If the tolerance is symmetrical in relation to the basic size, the value of the deviations should be indicated once only, preceded by the sign \pm (see figure 6).

iTeh STANDARD PREVIEW (standards.iteh.ai)

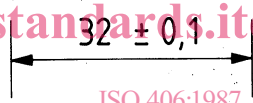

Figure 6

<https://standards.iteh.ai/catalog/standards/sist/9b923959-3164-479e-b43a-5d24292c443/iso-406-1987>
 ISO 406:1987

4.3 Limits of size

The limits of size may be indicated by an upper and lower dimension (see figure 7).

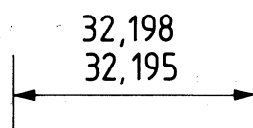

Figure 7

4.4 Limits of size in one direction

If a dimension needs to be limited in one direction only, this should be indicated by adding "min." or "max." to the dimension (see figure 8).

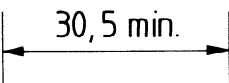

Figure 8

5 Order of indication of deviations and limits of size

The upper deviation or the upper limit of size shall be written in the upper position and the lower deviation or the lower limit of size in the lower position, irrespective of whether a hole or a shaft is tolerated.

6 Indication of tolerances on drawings of assembled parts

6.1 ISO symbols

The tolerance symbol for the hole shall be placed before that for the shaft (see figure 9) or above it (see figure 10), the symbols being preceded by the basic size indicated once only.

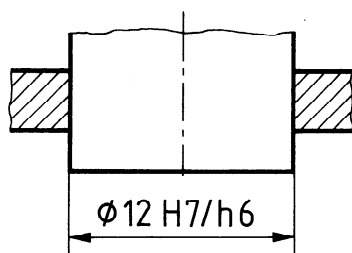

Figure 9

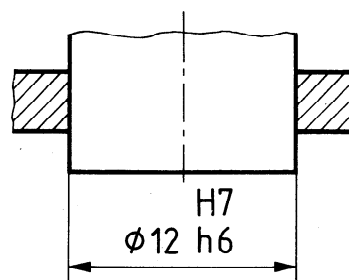

Figure 10

If it is also necessary to specify the numerical values of the deviations, they should be written in parentheses (see figure 11).

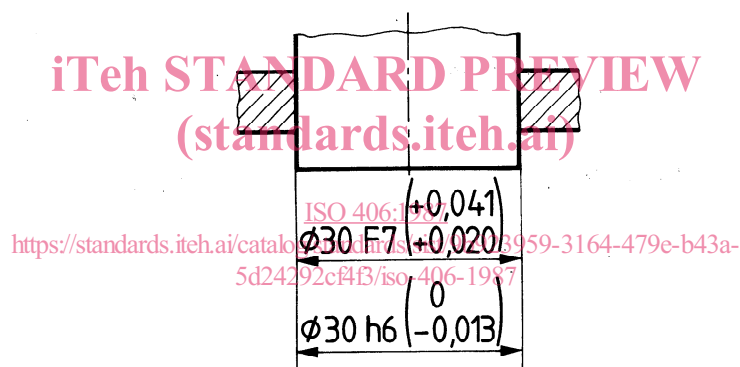

Figure 11

For the sake of simplicity (notwithstanding ISO 129), dimensioning with only one dimension line may be used (see figure 12).

6.2 Values by digits

The dimension for each of the components of the assembled parts shall be preceded by the name (see figure 12) or item reference (see figure 13) of the components, the dimension for the hole being placed in both cases above that for the shaft.

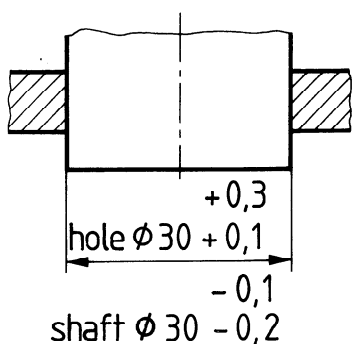

Figure 12

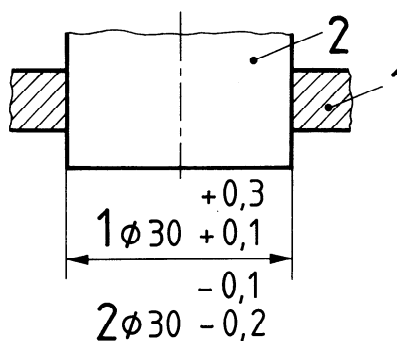

Figure 13

7 Indication of the components of an angular dimension

The rules given for the indication of tolerances on linear dimensions are equally applicable to angular dimensions, except that the units of the basic angle and the fractions thereof, as well as the deviations, shall always be indicated (see figures 14 to 17). If the angular deviation is expressed in either minutes of a degree or seconds of a minute of a degree, the value of the minute or second shall be preceded by 0° or 0'0', as applicable.

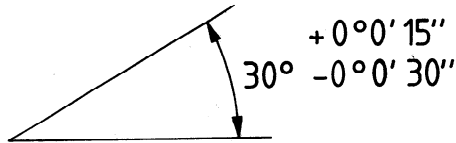

Figure 14

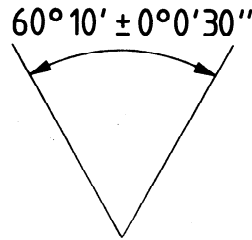

Figure 15



Figure 16

Figure 17

iteh STANDARD PREVIEW
 (standards.iteh.ai)
 ISO 406:1987
<https://standards.iteh.ai/catalog/standards/sist/9b923959-3164-479e-b43a-5d24292c4f3/iso-406-1987>

iTeh STANDARD PREVIEW
(standards.iteh.ai)

This page intentionally left blank

ISO 406:1987

<https://standards.iteh.ai/catalog/standards/sist/9b923959-3164-479e-b43a-5d24292cf4f3/iso-406-1987>

iTeh STANDARD PREVIEW
(standards.iteh.ai)

ISO 406:1987

<https://standards.iteh.ai/catalog/standards/sist/9b923959-3164-479e-b43a-5d24292cf4f3/iso-406-1987>

UDC 744.43 : 621. 753.1 : 003.62

Descriptors : drawings, technical drawings, dimensioning, dimensional tolerances, angular tolerances, designation.

Price based on 4 pages
