



Designation: ~~A 556/A 556M-96 (Reapproved 2001)~~ Designation: A556/A556M – 96 (Reapproved 2005)

Standard Specification for Seamless Cold-Drawn Carbon Steel Feedwater Heater Tubes¹

This standard is issued under the fixed designation A556/A556M; the number immediately following the designation indicates the year of original adoption or, in the case of revision, the year of last revision. A number in parentheses indicates the year of last reapproval. A superscript epsilon (ϵ) indicates an editorial change since the last revision or reapproval.

1. Scope

1.1 This specification² covers minimum-wall-thickness, seamless cold-drawn carbon steel tubes including bending into the form of U-tubes, if specified, for use in tubular feedwater heaters.

1.2 The tubing sizes covered shall be $\frac{5}{8}$ to $1\frac{1}{4}$ -in. [15.9 to 31.8-mm] outside diameter, inclusive, with minimum wall thicknesses equal to or greater than 0.045 in. [1.1 mm].

1.3 Optional supplementary requirements are provided, and when desired, shall be stated in the order.

1.4 The values stated in either inch-pound units or SI units are to be regarded separately as the standard. Within the text, the SI units are shown in brackets. The values stated in each system are not exact equivalents; therefore, each system must be used independently of the other. Combining values from the two systems may result in nonconformance with the specification. The inch-pound units shall apply unless the “M” designation of this specification is specified in the order.

2. Referenced Documents

2.1 *ASTM Standards*:³

A450/A450M Specification for General Requirements for Carbon, Ferritic Alloy, Carbon and Austenitic Low Alloy Steel Tubes
E30 Test Methods for Chemical Analysis of Steel, Cast Iron, Open-Hearth Iron, and Wrought Iron⁴

3. Ordering Information

3.1 Orders for material under this specification should include the following as required to describe the desired material adequately:

3.1.1 Quantity (feet, metres, or number of pieces),

3.1.2 Name of material (seamless steel tubing),

3.1.3 Dimensions (outside diameter and minimum wall thickness), 96(2005)

3.1.4 Length (specific or random),

3.1.5 Manufacture (cold drawn),

3.1.6 Grade (chemical composition),

3.1.7 Optional requirements,

3.1.8 *Bending Requirements*— If order specifies tubes to be bent, the design of the U-tubes shall accompany the order. Purchaser must specify if stress-relief anneal of the U-bends is required,

3.1.9 Test report required (see Certification Section of Specification ~~A 450/A 450M~~A450/A450M),

3.1.10 Specification number, and

3.1.11 Special requirements and any supplementary requirements selected.

4. General Requirements

4.1 Material furnished to this specification shall conform to the applicable requirements of the current edition of the

¹ This specification is under the jurisdiction of ASTM Committee A01 on Steel, Stainless Steel and Related Alloys and is the direct responsibility of Subcommittee A01.09 on Carbon Steel Tubular Products.

Current edition approved October 10, 1996. Published October 1997. Originally published as A 556-65. Last previous edition A 556-90 (1995)^{e1}.

Current edition approved Oct. 1, 2005. Published November 2005. Originally approved in 1965. Last previous edition approved in 2001 as A556/A556M – 96 (2001). DOI: 10.1520/A0556_A0556M-96R05.

² For ASME Boiler and Pressure Vessel Code applications see related Specification SA-556 in Section II of that Code.

³ For referenced ASTM standards, visit the ASTM website, www.astm.org, or contact ASTM Customer Service at service@astm.org. For Annual Book of ASTM Standards volume information, refer to the standard's Document Summary page on the ASTM website.

⁴ Annual Book of ASTM Standards, Vol 03.05.

^{e1} Withdrawn. The last approved version of this historical standard is referenced on www.astm.org.

Specification A 450/A 450MA450/A450M, unless otherwise provided herein.

5. Manufacture

5.1 *Manufacture*—Tubes shall be made by the seamless process and shall be cold drawn.

5.2 *Heat Treatment*:

5.2.1 Cold-drawn tubes shall be heat treated after the final cold-draw pass at a temperature of 1200°F [640°C] or higher to ensure ductility satisfactory for rolling into tube sheets and to meet mechanical properties as specified.

5.2.2 If stress-relief anneal of the U-bends is specified, the anneal shall consist of heating the bent portion within a range of 1100 to 1200°F [585 to 640°C].

6. Chemical Composition

6.1 The steel shall conform to one of the requirements as to chemical composition as prescribed in Table 1.

6.2 When a grade is ordered under this specification, supplying an alloy grade that specifically requires the addition of any element other than those listed for the ordered grade in Table 1 is not permitted.

7. Product Analysis

7.1 When requested in the purchase order, a product analysis shall be made by the manufacturer or supplier from one tube or billet per heat.

7.2 If the original test for product analysis fails, retests of two additional tubes or billets shall be made. Both retests for the elements in question shall meet the requirements of this specification; otherwise, all remaining material in the heat or lot (Note 1) shall be rejected or, at the option of the producer, each tube may be individually tested for acceptance. Tubes that do not meet the requirements of this specification shall be rejected.

NOTE 1—For tension and hardness test requirements, the term *lot* applies to all tubes prior to cutting, of the same nominal diameter and wall thickness which are produced from the same heat of steel. When final heat treatment is in a batch-type furnace, a lot shall include only those tubes of the same size and the same heat which are heat treated in the same furnace charge. When the final heat treatment is in a continuous furnace, a lot shall include all tubes of the same size and heat, heat treated in the same furnace at the same temperature, time at heat and furnace speed.

7.3 For referee purposes, Test Methods E-30E30 shall be used.

8. Mechanical Properties

8.1 *Tensile Properties*—The material shall conform to the requirements as to tensile properties prescribed in Table 2, when pulled in full section.

8.2 *Hardness Requirements*—The tubes shall not exceed the Rockwell Hardness shown in Table 3.

9. Permissible Variations in Dimensions (Fig. 1)

9.1 Permissible variations from the specified outside diameter shall not exceed ± 0.004 in. [0.10 mm] for tubing under 1.0-in. [25.4-mm] outside diameter nor ± 0.006 in. [0.15 mm] for tubing 1.0 in. [25.4 mm] to 1.25 in. [31.7 mm] inclusive. These tolerances do not apply to the bent portion of the U-tubes. At the bent portion of a U-tube for $R = 2 \times D$ or greater neither the major nor minor diameter of tube shall deviate from nominal by more than 10 %. If $1\frac{1}{2} D$ is specified, tolerances could be greater.

9.2 Permissible variations from the specified minimum wall thickness shall not exceed +20 % or –0. The wall thickness of the tube in U-bent section shall be not less than value determined by:

$$t_f = T(2R) / (2R + D) \quad (1)$$

A0556_A0556M-96R05_1

where:

t_f = wall thickness after bending, in. [mm],

T = specified minimum tube wall thickness, in. [mm],

R = centerline bend radius, in. [mm], and

D = nominal outside tube diameter, in. [mm].

9.3 In the case of U-tubes, the length of the tube legs as measured from the point of tangency of the bend and the tube leg to the end of the tube leg shall not be less than specified, but may exceed the specified values by the amount given in Table 4. The

TABLE 1 Chemical Requirements

Element	Composition, %		
	Grade A2	Grade B2	Grade C2
Carbon, max	0.18	0.27	0.30
Manganese	0.27–0.63	0.29–0.93	0.29–1.06
Phosphorus, max	0.035	0.035	0.035
Sulfur, max	0.035	0.035	0.035
Silicon, min	...	0.10	0.10

TABLE 2 Tensile Requirements

	Grade A2	Grade B2	Grade C2
Tensile strength, min, ksi [MPa]	47 [320]	60 [410]	70 [480]
Yield strength, min, ksi [MPa]	26 [180]	37 [260]	40 [280]
Elongation in 2 in. or 50 mm, min, % (longitudinal)	35	30	30

TABLE 3 Hardness Requirements

Grade A2	HR B 72
Grade A2	HR B 72
Grade B2	HR B 79
Grade B2	HR B 79
Grade C2	HR B 89
Grade C2	HR B 89

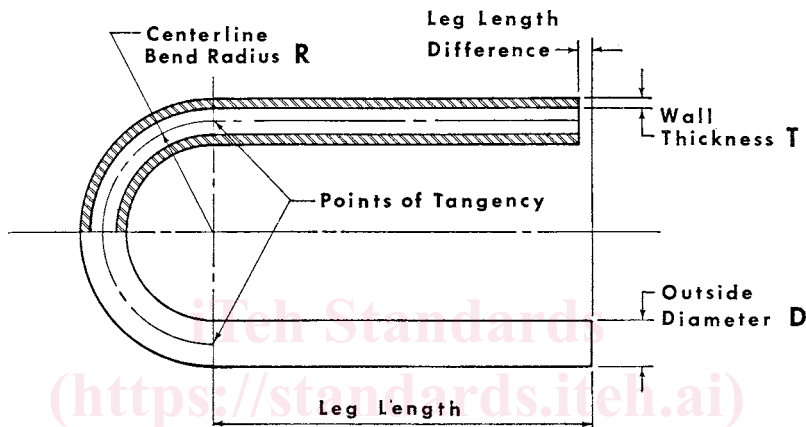

FIG. 1 Bent Portion of U-Tube

TABLE 4 Tube Leg Length Tolerance

Leg Length, ft [m]	Plus Tolerance in. [mm]
Up to 20 [6], incl	1/8 [3.2]
Over 20 to 30 [6 to 9], incl	5/32 [4.0]
Over 30 to 40 [9 to 12.2], incl	3/16 [4.8]

difference in lengths of the tube legs shall not be greater than 1/8 in. [3 mm] unless otherwise specified.

9.4 The end of any tube may depart from square by not more than the amount given in Table 5.

9.5 The leg spacing measured between the points of tangency of the bend to the legs shall not vary from the value (2R – specified tube OD) by more than 1/16 in. [1.5 mm] where R is the centerline bend radius.

9.6 The bent portion of the U-tube shall be substantially uniform in curvature and not exceed ±1/16 in. [±1.5 mm] of the normal centerline radius.

10. Workmanship, Finish, and Appearance

10.1 Finished tubes shall be free from scale but may have a superficial oxide film on the surfaces. A light oxide scale on the outside and inside surfaces of U-bend shall be allowed for tubes which have been heat treated.

10.2 Finished tubes shall be reasonably straight and have smooth ends free from burrs. Tubes shall have a workmanlike finish and shall be free of surface imperfections that cannot be removed within the allowable wall tolerances. Removal of surface imperfections such as handling marks, straightening marks, light mandrel and die marks, shallow pits, and scale pattern will not be required provided they are within the allowable wall tolerances.

TABLE 5 Squareness of Ends Tolerance

Tube OD, in. [mm]	Tolerance, in. [mm]
5/8 [15.9]	0.010 [0.25]
Over 5/8 to 1 1/4 [15.9 to 31.7], incl	0.016 [0.4]