

---

---

**Plastics — Film and sheeting —  
Determination of water vapour  
transmission rate —**

**Part 4:  
Gas-chromatographic detection sensor  
method**

iTeh STANDARD PREVIEW

(standards.iteh.ai)  
*Plastiques — Film et feuille — Détermination du coefficient de  
transmission de vapeur d'eau —*

*Partie 4: Méthode utilisant un détecteur à chromatographie en phase*

*gazeuse*  
<https://standards.iteh.ai/standards/sist/82d024c2-28d1-46a0-8186-2822a034f84c/iso-15106-4-2008>



**PDF disclaimer**

This PDF file may contain embedded typefaces. In accordance with Adobe's licensing policy, this file may be printed or viewed but shall not be edited unless the typefaces which are embedded are licensed to and installed on the computer performing the editing. In downloading this file, parties accept therein the responsibility of not infringing Adobe's licensing policy. The ISO Central Secretariat accepts no liability in this area.

Adobe is a trademark of Adobe Systems Incorporated.

Details of the software products used to create this PDF file can be found in the General Info relative to the file; the PDF-creation parameters were optimized for printing. Every care has been taken to ensure that the file is suitable for use by ISO member bodies. In the unlikely event that a problem relating to it is found, please inform the Central Secretariat at the address given below.

**iTeh STANDARD PREVIEW**  
**(standards.iteh.ai)**

[ISO 15106-4:2008](#)

<https://standards.iteh.ai/catalog/standards/sist/82d024c2-28d1-46a0-8186-2822a034f84c/iso-15106-4-2008>



**COPYRIGHT PROTECTED DOCUMENT**

© ISO 2008

All rights reserved. Unless otherwise specified, no part of this publication may be reproduced or utilized in any form or by any means, electronic or mechanical, including photocopying and microfilm, without permission in writing from either ISO at the address below or ISO's member body in the country of the requester.

ISO copyright office  
Case postale 56 • CH-1211 Geneva 20  
Tel. + 41 22 749 01 11  
Fax + 41 22 749 09 47  
E-mail [copyright@iso.org](mailto:copyright@iso.org)  
Web [www.iso.org](http://www.iso.org)

Published in Switzerland

## Contents

|                               | Page |
|-------------------------------|------|
| 1 Scope .....                 | 1    |
| 2 Normative references .....  | 1    |
| 3 Terms and definitions ..... | 1    |
| 4 Principle .....             | 1    |
| 5 Test specimens .....        | 1    |
| 6 Conditioning .....          | 2    |
| 7 Apparatus .....             | 2    |
| 8 Test conditions .....       | 4    |
| 9 Calibration graph .....     | 4    |
| 10 Procedure .....            | 4    |
| 11 Calculation .....          | 5    |
| 12 Test result .....          | 5    |
| 13 Precision .....            | 5    |
| 14 Test report .....          | 6    |
| Bibliography .....            | 7    |

iTech STANDARD PREVIEW  
(standards.iteh.ai)

[ISO 15106-4:2008](https://standards.iteh.ai/catalog/standards/sist/82d024c2-28d1-46a0-8186-2822a034f84c/iso-15106-4-2008)

<https://standards.iteh.ai/catalog/standards/sist/82d024c2-28d1-46a0-8186-2822a034f84c/iso-15106-4-2008>

## Foreword

ISO (the International Organization for Standardization) is a worldwide federation of national standards bodies (ISO member bodies). The work of preparing International Standards is normally carried out through ISO technical committees. Each member body interested in a subject for which a technical committee has been established has the right to be represented on that committee. International organizations, governmental and non-governmental, in liaison with ISO, also take part in the work. ISO collaborates closely with the International Electrotechnical Commission (IEC) on all matters of electrotechnical standardization.

International Standards are drafted in accordance with the rules given in the ISO/IEC Directives, Part 2.

The main task of technical committees is to prepare International Standards. Draft International Standards adopted by the technical committees are circulated to the member bodies for voting. Publication as an International Standard requires approval by at least 75 % of the member bodies casting a vote.

Attention is drawn to the possibility that some of the elements of this document may be the subject of patent rights. ISO shall not be held responsible for identifying any or all such patent rights.

ISO 15106-4 was prepared by Technical Committee ISO/TC 61, *Plastics*, Subcommittee SC 11, *Products*.

ISO 15106 consists of the following parts, under the general title *Plastics — Film and sheeting — Determination of water vapour transmission rate*:

- Part 1: Humidity detection sensor method
- Part 2: Infrared detection sensor method
- Part 3: Electrolytic detection sensor method
- Part 4: Gas-chromatographic detection sensor method

# Plastics — Film and sheeting — Determination of water vapour transmission rate —

## Part 4: Gas-chromatographic detection sensor method

### 1 Scope

This part of ISO 15106 specifies an instrumental method for determining the water vapour transmission rate of single-layer plastic film and sheet, as well as multi-layer structures including plastics, using a gas chromatograph.

NOTE The method provides rapid measurement over a wide range of water vapour transmission rates.

### 2 Normative references

The following referenced documents are indispensable for the application of this document. For dated references, only the edition cited applies. For undated references, the latest edition of the referenced document (including any amendments) applies.

ISO 4593, *Plastics — Film and sheeting — Determination of thickness by mechanical scanning*

<https://standards.iteh.ai/catalog/standards/sist/82d024c2-28d1-46a0-8186-2822a034f84c/iso-15106-4-2008>

### 3 Terms and definitions

For the purposes of this document, the following terms and definitions apply.

#### 3.1

#### water vapour transmission rate

#### WVTR

amount of water vapour transmitted through unit area of test specimen per unit time under specified conditions

NOTE Water vapour transmission rate is expressed in grams per square metre 24 hours [ $\text{g}/(\text{m}^2 \cdot 24 \text{ h})$ ].

### 4 Principle

A dry chamber, evacuated by a vacuum pump, is separated from a wet chamber, in which the relative humidity of a gas flow is controlled at a specified level, by a test specimen. The water vapour transmitted through the specimen is collected in a sampling loop for a certain period of time. The absolute mass of the water collected is measured using a gas chromatograph. The water vapour transmission rate is then calculated from the mass of water vapour transmitted, the period of time and the transmission area of the specimen.

### 5 Test specimens

**5.1** The specimens shall be representative of the material, be free from wrinkles, creases and pinholes, and have uniform thickness. Each specimen shall have a larger area than the transmission area of the cell, and shall be hermetically mounted.

**5.2** Three determinations shall be made using separate specimens unless otherwise specified or agreed between the interested parties.

NOTE For some products, testing more than three specimens gives a more representative result.

**5.3** Unless otherwise specified, determine the thickness of each specimen in accordance with ISO 4593 at three equally spaced points.

## 6 Conditioning

The specimens, whose thickness has been determined in accordance with ISO 4593, shall be conditioned at the same temperature and humidity as specified for the test for a length of time appropriate to the material under test, unless otherwise agreed between the interested parties.

NOTE If the gas-chromatographic apparatus includes a test cell having an automatic conditioning system, the test specimens can be placed in the cell for conditioning.

## 7 Apparatus

### 7.1 General

An example of a suitable apparatus is shown in Figure 1. The apparatus includes a gas transmission cell with two chambers, a sampling loop for holding permeated water vapour, switching valves, a gas chromatograph, a humidity controller (water reservoir) and a vacuum pump.

### 7.2 Transmission cell

iTeh STANDARD PREVIEW  
(standards.iteh.ai)

The transmission cell shall consist of a wet chamber (upper side of the cell in Figure 1) and a dry chamber (lower side of the cell). The wet chamber shall have an inlet for the water vapour and the dry chamber shall be connected to a gas chromatograph via a sampling loop. The surfaces of the transmission cell in contact with the specimen shall be smooth and flat so that leakage does not occur. The transmission area shall be from 0,5 cm<sup>2</sup> to 100 cm<sup>2</sup>. The temperature of the transmission cell shall be kept within  $\pm 0,5$  °C of the test temperature by means of a temperature controller. The tubing system shall be kept at a higher temperature than that of the humidity controller in order to prevent the condensation of water vapour.

### 7.3 Gas chromatograph

The gas chromatograph shall be able to measure the quantity of water vapour in carrier gas with an accuracy of at least 0,05 µg.

### 7.4 Gas flow controller

The gas flow controller shall be capable of maintaining the gas flow to the humidity controller at a constant rate.

The recommended flow rate is between 5 ml/min and 100 ml/min.

### 7.5 Humidity controller (water reservoir)

A humidity controller that contains distilled or deionized water is connected to the wet chamber. The temperature of the water in the reservoir shall be kept within  $\pm 0,2$  °C of the temperature of the transmission cell (see Table 1). Gas shall be supplied to the humidity controller via the gas flow controller. The gas is bubbled through the water in the reservoir and becomes saturated with water vapour at that temperature.

### 7.6 Vacuum pump

The vacuum pump shall be capable of producing a vacuum lower than 10 Pa (0,075 mmHg) in the dry chamber.

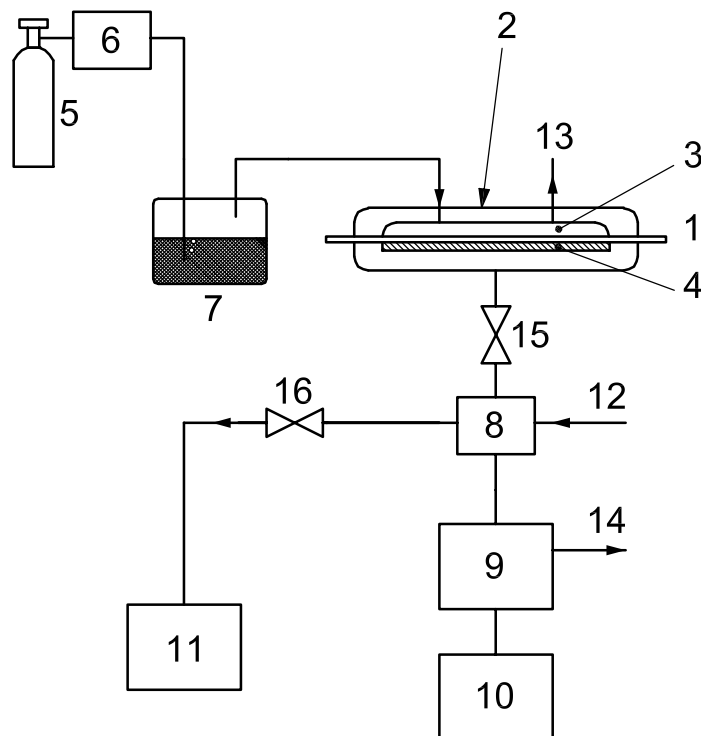

**iTeh STANDARD PREVIEW**  
(standards.iteh.ai)

<https://standards.iteh.ai/catalog/standards/sist/82d024c2-28d1-46a0-8186-2822a034f84c/iso-15106-4-2008>

<https://standards.iteh.ai/catalog/standards/sist/82d024c2-28d1-46a0-8186-2822a034f84c/iso-15106-4-2008>

**Key**

- 1 specimen
- 2 transmission cell
- 3 wet chamber
- 4 dry chamber with hydrophobic filter-paper
- 5 gas supply
- 6 gas controller
- 7 humidity controller with distilled or deionized water (water reservoir)
- 8 sampling loop
- 9 gas chromatograph
- 10 data processor
- 11 vacuum pump
- 12 carrier gas for gas chromatograph
- 13 gas exhaust
- 14 carrier gas exhaust
- 15 switching valve 1
- 16 switching valve 2

**Figure 1 — Example of apparatus for measuring WVTR by gas chromatography**

## 8 Test conditions

The test conditions should preferably be chosen from those given in Table 1.

**Table 1 — Choice of test conditions**

| Set of test conditions | Temperature<br>°C | RH of wet chamber<br>% | RH of dry chamber<br>% |
|------------------------|-------------------|------------------------|------------------------|
| 1                      | 25 ± 0,5          | 90 ± 2                 | 0                      |
| 2                      | 38 ± 0,5          | 90 ± 2                 | 0                      |
| 3                      | 40 ± 0,5          | 90 ± 2                 | 0                      |
| 4                      | 23 ± 0,5          | 85 ± 2                 | 0                      |
| 5                      | 25 ± 0,5          | 75 ± 2                 | 0                      |

Test conditions other than these, for example test conditions specified in ISO 291, shall be agreed upon by the interested parties.

## 9 Calibration graph

Prepare dilute solutions of water in alcohol at different levels of water concentration.

Inject a known volume of each solution into the gas chromatograph using a liquid syringe and record the chromatogram for each under the same conditions. Determine the area of the peak in the chromatogram corresponding to the injected water.

Produce a calibration graph by plotting water concentration against peak area and drawing a straight line through the points.

NOTE In the case of 1 % (by mass) of water in methanol, a straight line can be drawn from the origin through the point representing a measurement on this solution only.

## 10 Procedure

**10.1** Spread a hydrophobic filter-paper (4 in Figure 1) having the same size as the gas transmission area over the bottom of the dry chamber.

The hydrophobic filter-paper is used to support the specimen film and to ensure smooth water vapour transmission through the whole specimen area. A hydrophobic filter-paper recommended for this purpose is Polyflon<sup>1)</sup> filter-paper, which is made from polytetrafluoroethylene (PTFE). It is recommended that the thickness of the filter be the same as the depth of the dry chamber.

**10.2** Apply a thin, uniform coating of vacuum grease on the flat edges of the two halves of the transmission cell, and mount a specimen over the dry chamber in such a way that no creasing or slackness occurs.

**10.3** Place a rubber sealing-ring on the specimen, then set up the upper part of the cell. Clamp the two chambers together with a uniform pressure so that the specimen is completely sealed in place.

**10.4** Start the vacuum pump and evacuate all the air from the dry chamber. Care is necessary here, because the time taken to exhaust the cell completely will depend on the permeability of the specimen under test.

**10.5** Introduce water vapour into the wet chamber through the humidity controller in such a way that the wet chamber is kept at constant humidity. Water vapour permeating from the wet chamber to the dry chamber through the specimen is evacuated by the vacuum pump.

1) Polyflon<sup>TM</sup> is an example of a suitable product available commercially. This information is given for the convenience of users of this part of ISO 15106 and does not constitute an endorsement by ISO of this product.



**10.6** By closing valve 2 (16 in Figure 1), start collecting the water vapour which permeates through the specimen in the sampling loop (8). After a predetermined period of time  $t$ , close valve 1 and sweep the water vapour which has accumulated in the sampling loop into the chromatographic column (9) with carrier gas (12). Using the integrator of the chromatograph, determine the area of the peak in the chromatogram corresponding to the water vapour. Determine, from the calibration graph prepared in Clause 9, the amount of water vapour  $m_v$  which has accumulated in the sampling loop.

It is recommended that the purity of the carrier gas be greater than 99,99 %.

**10.7** Repeat steps 10.4, 10.5 and 10.6 until consecutive measurements show that a steady state has been reached in which the amount of water vapour which permeates through the specimen during the period of time  $t$  is constant to within  $\pm 5$  %.

**10.8** Either before or after the test, carry out a blank run to determine the (small) amount of water vapour present, under the steady-state conditions, in the sampling loop at the beginning of time  $t$ . Do this by simultaneously shutting valve 1 (15) and valve 2 (16), thus trapping the water vapour which is flowing through the loop under the steady-state conditions, and subsequently determining the amount of gas  $m_b$  trapped.

## 11 Calculation

Calculate the water vapour transmission rate of each test specimen using the following equation:

$$\text{WVTR} = \frac{(m_v - m_b) \times k}{A \times t} \times 24$$

where

**WVTR** is the water vapour transmission rate of the test specimen, expressed in grams per square metre 24 hours [g/(m<sup>2</sup> · 24 h)];

$t$  is the period of time during which water vapour was collected, in hours;

$m_b$  is the blank reading (see 10.8), in grams;

$m_v$  is the amount of water vapour which accumulated in the sampling loop, in grams;

$A$  is the transmission area of the specimen, in square metres;

$k$  is a conversion factor for converting the sampling loop volume to the total volume of the dry chamber.

NOTE The value of  $k$  depends on the particular type of apparatus and is given by the manufacturer.

## 12 Test result

Calculate the test result as the arithmetic mean of the results obtained for each test specimen, rounding to the second place of decimals if the value is less than one, and to two significant figures if the value is greater than one.

## 13 Precision

The precision of this test method is not known because inter-laboratory data are not available. When inter-laboratory data are obtained, a precision statement will be added at the following revision.