



Designation: E795 – 05

Standard Practices for Mounting Test Specimens During Sound Absorption Tests¹

This standard is issued under the fixed designation E795; the number immediately following the designation indicates the year of original adoption or, in the case of revision, the year of last revision. A number in parentheses indicates the year of last reapproval. A superscript epsilon (ϵ) indicates an editorial change since the last revision or reapproval.

This standard has been approved for use by agencies of the Department of Defense.

1. Scope

1.1 These practices cover test specimen mountings to be used during sound absorption tests performed in accordance with Test Method C423.

1.2 The values stated in SI units are to be regarded as the standard. The values given in parentheses are for information only.

2. Referenced Documents

2.1 *ASTM Standards*:²

C423 Test Method for Sound Absorption and Sound Absorption Coefficients by the Reverberation Room Method

C634 Terminology Relating to Building and Environmental Acoustics

2.2 *ISO Standard*:

ISO 354 Measurement of Sound Absorption in a Reverberation Room³

3. Terminology

3.1 *Definitions of Terms Specific to This Standard*:

3.1.1 Except as noted in 4.2, the terms used in these practices are defined in Terminology C634.

3.2 The following terms have the meaning noted for these practices only:

3.2.1 *sound-absorbing units* — consists of test specimens that are in direct contact with or suspended from ceilings, walls, or other room surfaces. Sound-absorbing units include, but are not limited to, baffles, draperies, space absorbers, volume absorbers (bass traps), and other three-dimensional objects.

¹ These practices are under the jurisdiction of ASTM Committee E33 on Building and Environmental Acoustics and are the direct responsibility of Subcommittee E33.01 on Sound Absorption.

Current edition approved Oct. 15, 2005. Published December 2005. Originally approved in 1981. Last previous edition approved in 2000 as E795–00. DOI: 10.1520/E0795-05.

² For referenced ASTM standards, visit the ASTM website, www.astm.org, or contact ASTM Customer Service at service@astm.org. For *Annual Book of ASTM Standards* volume information, refer to the standard's Document Summary page on the ASTM website.

³ Available from American National Standards Institute (ANSI), 25 W. 43rd St., 4th Floor, New York, NY 10036.

3.2.2 *test surface*—any hard surface over which the test specimen or test specimen mounting is placed for testing in accordance with Test Method C423. The surface shall satisfy the room construction requirements of Test Method C423. In most cases, the surface will be the floor of the reverberation room.

4. Significance and Use

4.1 The sound absorption of a material that covers a flat surface depends not only on the physical properties of the material but also on the way in which the material is mounted over the surface. The mountings specified in these practices are intended to simulate in the laboratory conditions that exist in normal use.

4.2 Some of the specified mountings require special fixtures or minor deviations from normal practice. These fixtures or deviations are to be used only during laboratory tests and should not be specified for practical installations. They are noted in the specifications for the mountings in question by the phrase “for laboratory testing only.”

4.3 Test reports may refer to these mountings by type designation instead of providing a detailed description of the mounting used.

5. Classification

5.1 The mountings are designated as follows:

5.1.1 *Type A Mounting*—Test specimen laid directly against the test surface (described in detail in Section 6).

5.1.2 *Type B Mounting*—Test specimen cemented to gypsum board and laid directly against the test surface (described in detail in Section 7).

5.1.3 *Type C Mounting*—Test specimen comprising sound-absorptive material behind a perforated, expanded, open facing or other porous material (described in detail in Section 8).

5.1.4 *Type D Mounting*—Test specimen mounted on wood furring strips (described in detail in Section 9).

5.1.5 *Type E Mounting*—Test specimen mounted with an air space behind it (described in detail in Section 10).

5.1.6 *Type F Mounting*—Test specimen mounted with an air space behind it (described in detail in Section 11).

5.1.7 *Type G Mounting*—Test specimen is a drapery, window shade, or blind hung parallel to the test surface (described in detail in Section 12).

5.1.8 *Type H Mounting*—Test specimen is a drapery suspended away from any vertical surface (described in detail in Section 13).

5.1.9 *Type I Mounting*—The specimen is a spray- or trowel-applied material on an acoustically hard substrate (described in detail in Section 14).

5.1.10 *Type J Mounting*—The specimen is a sound-absorbing unit or set of sound-absorbing units (described in detail in Section 15).

5.1.11 *Type K Mounting*—Test specimen is an office screen (described in detail in Section 16).

5.1.12 *Type L Mounting*—This mounting is for use with concrete blocks or block-like specimens that are normally assembled using mortar (described in detail in Section 17).

5.1.13 *Type M Mounting*—Test specimen is theater seats, (described in detail in Section 18).

5.2 Type C, D, E, and G mountings are further designated by a numerical suffix which indicates the distance (in millimetres) from the specimen to the test surface rounded to the nearest integral multiple of 5 mm. For example, a Type E-400 mounting is a plenum mounting in which the face of the test specimen is 400 mm (15¾ in.) away from the test surface. The distances specified by the suffixes are as follows:

5.2.1 *For a Type C Mounting*—The thickness of the furring strips.

5.2.2 *For a Type D Mounting*—The thickness of the furring strips.

5.2.3 *For a Type E Mounting*—The distance from the exposed face of the test specimen to the test surface.

5.2.4 *For a Type F Mounting*—The thickness of the spacers.

5.2.5 *For a Type G Mounting*—The distance from the centerline of the hangers to the test surface.

6. Type A Mounting

6.1 Lay the test specimen directly against the test surface as shown in Fig. 1.

6.2 Do not use an adhesive that is likely to leave a thin air space behind the test specimen. However, mechanical fasteners, carpet tape, or contact cement may be used to hold the specimen against a vertical or overhead surface or to keep the specimen in contact with the floor.

6.3 If two or more pieces of material (or separate panels) are butted together to form the test specimen, it may be advisable to cover the joints between adjacent pieces with tape, caulking compound, or other material that is not sound absorptive. If the

joints are sealed in this manner, the test report shall describe the method of sealing.

6.4 *Perimeter Seals for Laboratory Testing Only*—If the perimeter edges of the test specimen are not exposed in normal use, seal them by one of the following two methods:

6.4.1 Cover with tape, caulking compound, or a similar product as shown in Fig. 2.

6.4.2 Cover with a wood or metal frame so that the top surface of the frame is flush with the front face of the test specimen as shown in Fig. 2. Minimize air spaces between the frame and the perimeter edge of the test specimen. Air gaps between the bottom of the frame and the test surface shall be sealed with duct tape or caulking.

NOTE 1—The Type A mounting is intended to simulate normal use where a product, such as carpet, wall panels, or ceiling tile is either laid directly on the floor or attached to a wall or ceiling with adhesive or mechanical fasteners. Panels or tiles arranged as independent units, that is, not butted together at the edges to form a single extended plane, are to be tested as a Type J mounting.

7. Type B Mounting

7.1 Adhere the test specimen to gypsum board laid directly against the test surface as shown in Fig. 3. The thickness of the gypsum board is not critical.

7.2 Apply the adhesive in accordance with the manufacturer’s instructions. If there are no specific instructions, apply four daubs of adhesive to the back of each piece of the test specimen.

7.3 *For Laboratory Testing Only*—Place 3 by 25 by 25-mm (¼ by 1 by 1-in.) hardboard shims between the test specimen and the gypsum board at the four corners of each piece of test specimen.

7.4 *Perimeter Seals, for Laboratory Testing Only*—Seal the perimeter edges of the test specimen by one of the following methods:

7.4.1 Cover with tape, caulking compound, or a similar product as shown in Fig. 2.

7.4.2 Cover with a wood or metal frame so that the top surface of the frame is flush with the front face of the test specimen as shown in Fig. 2. Minimize air spaces between the frame and the perimeter edge of the test specimen. Air gaps between the bottom of the frame and the test surface shall be sealed with duct tape or caulking.

NOTE 2—The Type B mounting is intended to simulate acoustical ceiling tiles or other sound-absorptive products adhered to a hard surface with an adhesive. In normal use, this method of application leaves a thin air space between the product and the surface to which it is adhered. The

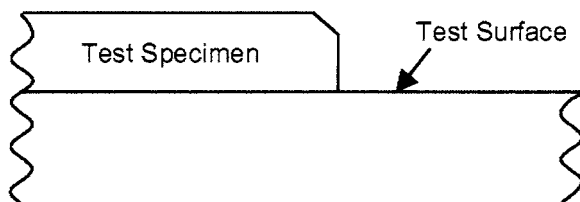
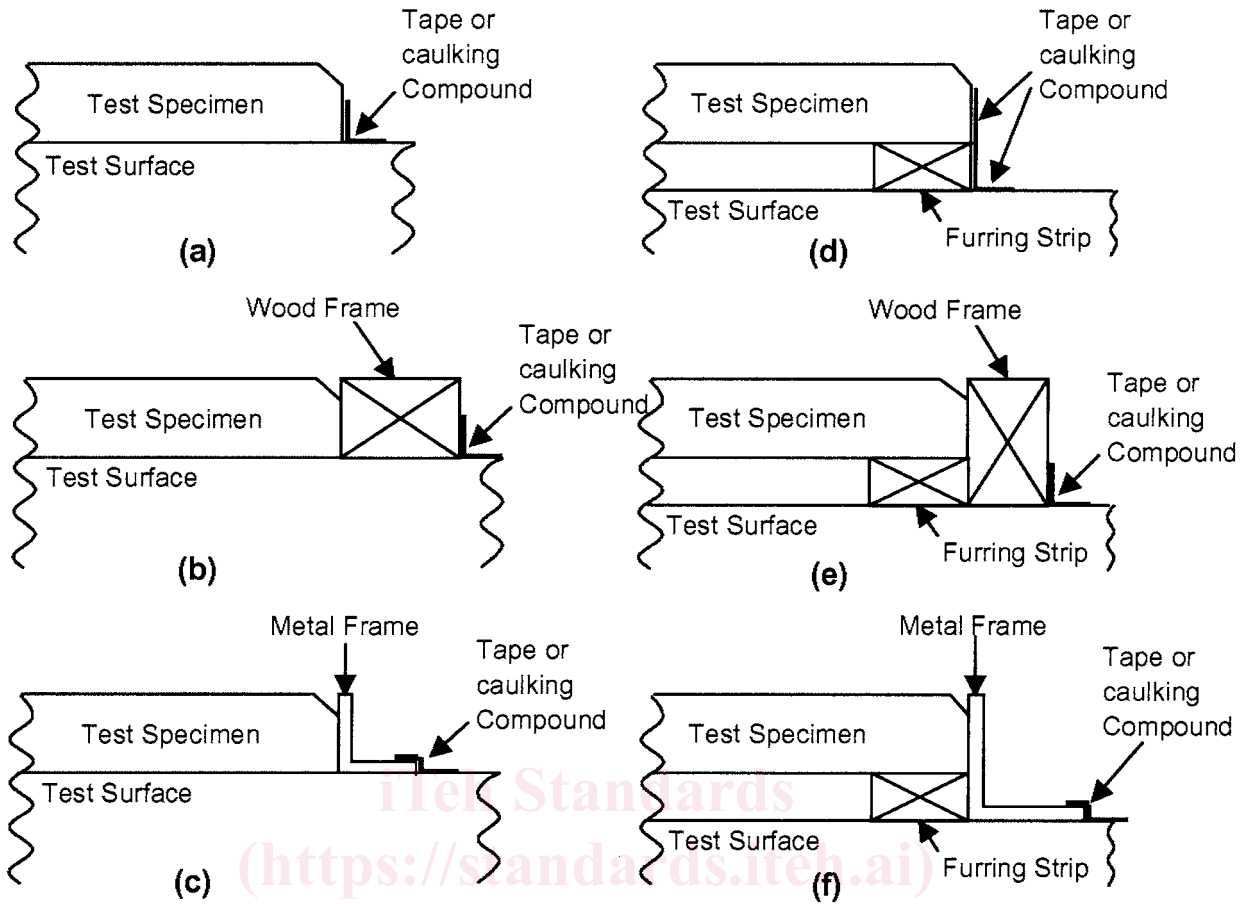

FIG. 1 Type A Mounting



- (a) Tape or caulking compound used to seal a Type A or Type B mounting.
- (b) Wood frame used to seal a Type A or Type B mounting.
- (c) Metal angle frame used to seal Type A or Type B mounting.
- (d) Tape or caulking compound used to seal a Type D mounting.
- (e) Wood frame used to seal a Type D mounting.
- (f) Metal angle frame used to seal a Type D mounting.

FIG. 2 Typical Edge Seals

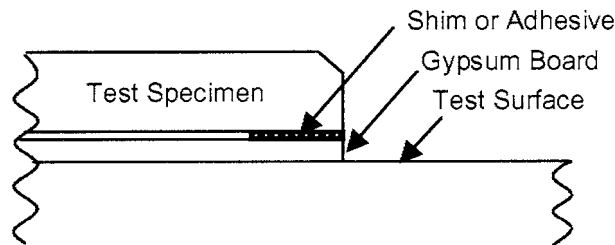

FIG. 3 Type B Mounting

3-mm (1/8-in.) thick hardboard shims are used to control the depth of the air space during laboratory tests and should not be included in a normal installation.

8. Type C Mounting

8.1 The test specimen shall comprise sound-absorptive material behind a perforated, expanded, open facing, or other porous material attached to wood furring strips spaced 600 mm

(24 in.) on centers and laid directly against the test surface as shown in Fig. 4. The suffix of the mounting designation shall be the actual thickness of the furring strips rounded to the nearest integral multiple of 5 mm.

8.1.1 The length of the furring strips described in 8.1 shall be shorter than the length of the test specimen by an amount equal to twice the width of the furring strips. This will allow

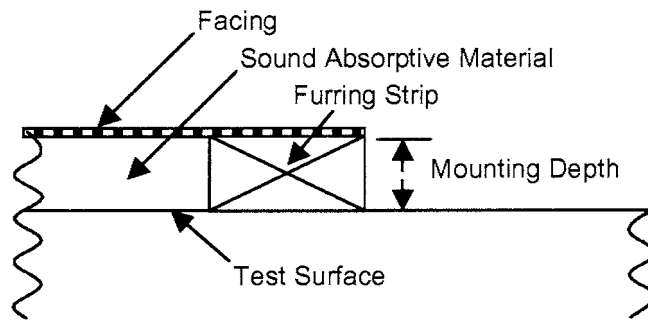

FIG. 4 Type C Mounting

the placement of a furring strip at each end of the system to act as an “end cap” and completely enclose the airspace below the test specimen.

8.2 *Perimeter Seals, for Laboratory Testing Only*—The perimeter furring strips of the test specimen shall be sealed to the test surface with tape or caulking compound.

NOTE 3—The preferred sizes for furring strips are 20 by 40 mm (¾ by 1½ in.) or 40 by 40 mm (1½ by 1½ in.), which corresponds to a C-20 or C-40 mounting.

9. Type D Mounting

9.1 Attach the test specimen to wood furring strips spaced at 300 mm (12 in.) on centers and laid directly against the test surface as shown in Fig. 5. The suffix of the mounting designation shall be the actual thickness of the furring strips rounded to the nearest integral multiple of 5 mm.

9.1.1 The length of the furring strips described in 9.1 shall be shorter than the length of the test specimen by an amount equal to twice the width of the furring strips. This will allow the placement of a furring strip at each end of the system to act as an “end cap” and completely enclose the airspace below the test specimen.

9.2 *Perimeter Seals, for Laboratory Testing Only*—Seal the perimeter edges of the test specimen by one of the following methods:

9.2.1 Cover with tape, caulking compound, or a similar product as shown in Fig. 2.

9.2.2 Cover with a wood or metal frame so that the top surface of the frame is flush with the front face of the test specimen as shown in Fig. 2. Minimize air spaces between the frame and the perimeter edge of the test specimen. Air gaps between the bottom of the frame and the test surface shall be sealed with duct tape or caulking.

NOTE 4—The preferred size for furring strips is 20 by 40 mm (¾ by 1½ in.). This is a D20 mounting.

NOTE 5—If a different on center spacing of the wood furring strips is used, the spacing shall be noted in the report.

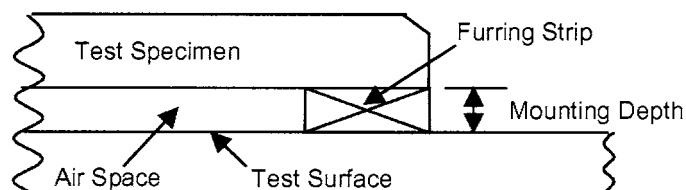

FIG. 5 Type D Mounting

10. Type E Mounting

10.1 Mount the test specimen in a fixture that supports the exposed face of the specimen at a designated distance from the test surface as shown in Fig. 6. The suffix of the mounting designation shall be the distance between the exposed face of the specimen and the test surface rounded to the nearest integral multiple of 5 mm.

10.2 *Mounting Fixture for Laboratory Testing Only*—The mounting fixture shall satisfy the following requirements:

10.2.1 The mounting fixture, test specimen, and test surface shall enclose an air space that has no interior partitions.

10.2.2 The joint between the fixture and the test surface shall be sealed to prevent air leaks between the enclosed space and the outside.

10.2.3 The fixture shall include a rigid grid system that supports the exposed face of the test specimen at the required distance from the test surface. The distance from the exposed face of the test specimen (excluding decorative features) to the test surface shall not vary by more than 5 mm (0.20 in.), across the entire face of the specimen.

10.2.4 The fixture shall seal the perimeter edges of the test specimen, and the top surface of the fixture shall be flush with the front face of the test specimen as shown in Fig. 6.

10.2.5 The mounting fixture shall be made of a sturdy material, such as 20-mm (¾-in.) thick plywood or 3-mm (⅛-in.) thick aluminum.

10.2.6 If a grid system is placed between the panels, on the exposed side of the specimen, the grid size and arrangement shall be noted in the report.

NOTE 6—Type E mountings are intended to simulate a suspended ceiling with an open plenum above it.

NOTE 7—When there is good reason to test on a Type E mounting other than Type E-400, a mounting whose suffix is an integral multiple of 25 is preferred (for example, E-375, E-425, and so forth).

NOTE 8—It has been found that if a gasket is used between the test fixture and the test surface, placing the gasket so that it is flush with the exterior surface of the test fixture will minimize the variability in results.

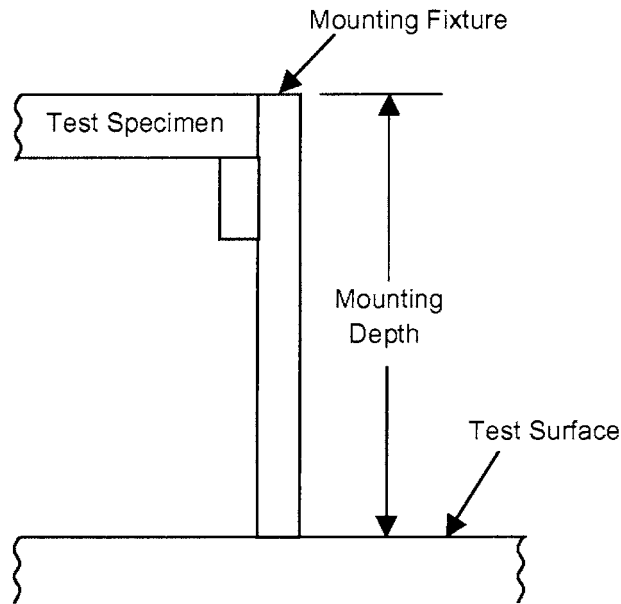

FIG. 6 Type E Mounting

11. Type F Mounting

11.1 Lay the test specimen with spacers against the test surface as shown in Fig. 7. If spacers are not an integral part of the specimen then metal furring, solid wood blocks, or similar items may be used to space the product away from the test surface. The suffix of the mounting designation shall be the actual thickness of the spacers rounded to the nearest integral multiple of 5 mm for spacers 10 mm thick or greater and to the nearest integral multiple of 1 mm for those less than 10 mm.

NOTE 9—Any specimen with a spacer less than 1 mm shall be tested and reported as Type A mounting.

11.2 If two or more pieces of material (or separate panels) are butted together to form the test specimen, it may be advisable to cover the joints between adjacent pieces with tape, caulking compound, or other material that is not sound absorptive. If the joints are sealed in this manner, the test report shall describe the method of sealing.

11.3 *Perimeter Seals for Laboratory Testing Only*—If the perimeter edges of the test specimen are not exposed in normal use, seal them by one of the following two methods:

11.3.1 Cover with tape, caulking compound, or a similar product as shown in Fig. 2.

11.3.2 Cover with a wood or metal frame so that the top surface of the frame is flush with the front face of the test specimen as shown in Fig. 2. Minimize air spaces between the frame and the perimeter edge of the test specimen. Air gaps between the bottom of the frame and the test surface shall be sealed with duct tape or caulking

NOTE 10—The Type F mounting is intended to simulate normal use where a product, such as, wall panels, has integral spacers, spacing clips, Z-furring or other devices for sustaining an airspace between the panel and a wall or ceiling. This mounting type will include specimens with spacers

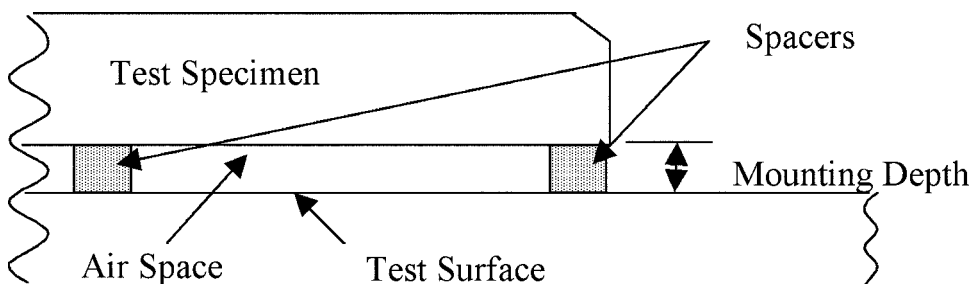

Figure 7: Type F Mounting

FIG. 7 Type F Mounting

which may or may not be integral to the construction of the panel. Panels or tile arranged as independent units, that is, not butted together at the edges to form a single extended plane, are to be tested as a Type J mounting.

12. Type G Mounting

12.1 The test specimen shall be a drapery, window shade, or window blind hung parallel to the test surface. The suffix of the mounting designation shall be the distance from the test surface to the centerline of the hangers rounded to the nearest integral multiple of 5 mm.

12.2 Attach the hangers to a solid beam or plank that is butted against the test surface as shown in Fig. 8. The beam or plank should prevent sound waves from passing over the top of the test specimen, into or out of the space behind it.

NOTE 11—The preferred distance between the centerline of the hangers and the test surface is 75 mm (3 in.). If another distance is used, it should be an integral multiple of 25 mm.

13. Type H Mounting

13.1 The test specimen shall be a drapery. The distance between the suspended drapery and any vertical surface, rotating vane, or diffuser panel shall be consistent with the requirements of Test Method C423. The drapery shall not be parallel to any wall as shown in Fig. 9.

NOTE 12—Type H mountings are intended to simulate draperies used as sound-absorbing units.

14. Type I Mounting

14.1 Spray or trowel the material to be tested on to a substrate that satisfies the following conditions:

14.1.1 The substrate shall be no more than 25 mm (1 in.) thick.

14.1.2 The sound absorption coefficients of the substrate shall be less than 0.05 in each frequency band when tested on a Type A mounting in accordance with Test Method C423.

14.1.3 The substrate shall not cup or warp after the material has been applied.

14.1.4 There shall be negligible air space between the back of the substrate and the test surface.

14.1.5 If the sound absorption of the material to be tested depends on the orientation and position of the substrate (that is, vertical, horizontal above the material, or horizontal beneath the material), the material shall be applied with the substrate in the orientation and position of interest. The specimen shall remain in that orientation and position until the material has cured completely.

14.1.6 *Joint Seals for Laboratory Tests Only*—If the substrate comprises panels that are fitted together for the test, the joints between the panels shall be sealed with caulking compound.

14.2 *Perimeter Seals, for Laboratory Testing Only*—Seal the perimeter edges of the test specimen by one of the following methods:

14.2.1 Cover with tape, caulking compound, or a similar product as shown in Fig. 2.

14.2.2 Cover with a wood or metal frame so that the top surface of the frame is flush with the front face of the test specimen as shown in Fig. 2. Minimize air spaces between the frame and the perimeter edge of the test specimen. Air gaps

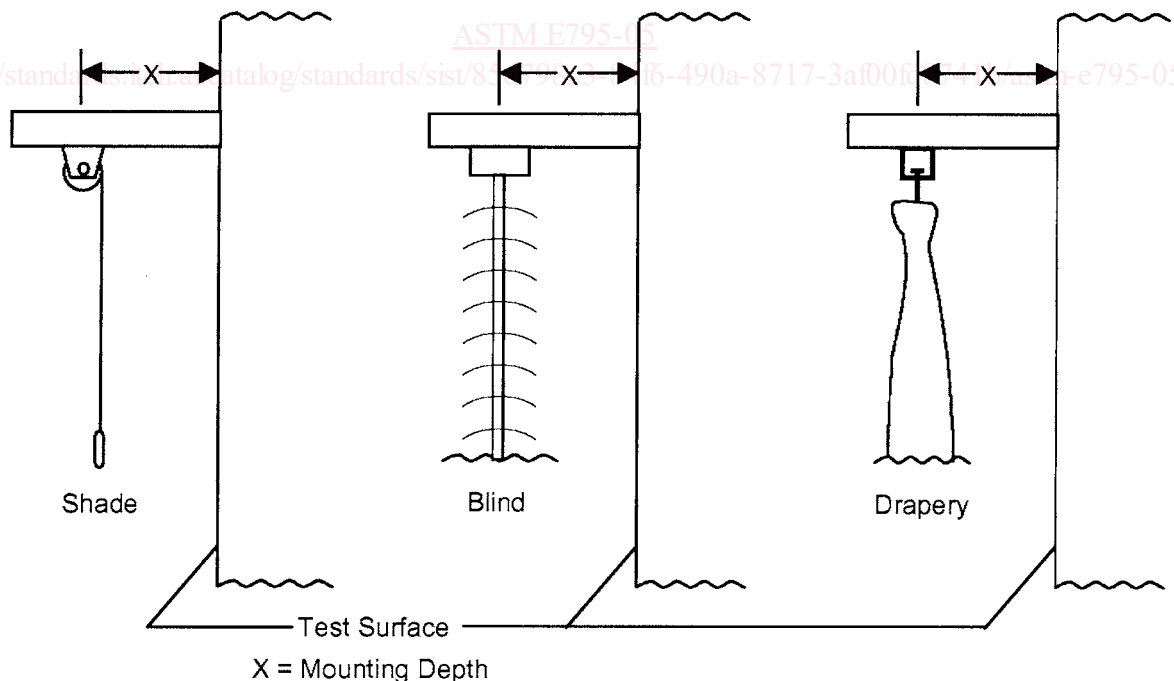

FIG. 8 Type G Mounting