



Designation: F590 – 05

## Standard Consumer Safety Specification for Non-Powder Gun Projectiles and Propellants<sup>1</sup>

This standard is issued under the fixed designation F590; the number immediately following the designation indicates the year of original adoption or, in the case of revision, the year of last revision. A number in parentheses indicates the year of last reapproval. A superscript epsilon ( $\epsilon$ ) indicates an editorial change since the last revision or reapproval.

### 1. Scope

1.1 This consumer safety specification covers projectiles and propellants manufactured for use with non-powder guns intended for target shooting, educational, and recreational purposes and is to be used in conjunction with Consumer Safety Specification F589. Non-powder guns are commonly identified as BB guns, air guns, or pellet guns.

1.2 The projectiles and propellants covered by this consumer safety specification are BB cal, .177 cal (4.5 mm), .22 cal (5.5 mm), and .25 cal (6.4 mm) air gun shot of various materials; .177 cal (4.5 mm), 5 mm, .22 cal (5.5 mm), .25 cal (6.4 mm) pellets and .177 cal (4.5 mm), 5 mm, .22 cal (5.5 mm), and .25 cal (6.4 mm) darts and propellants identified as 8 and 12-g type CO<sub>2</sub> cylinders with both small and standard-sized necks.

1.3 This consumer safety specification does not cover propellants such as dichlorodifluoromethane or projectiles that are propelled by a combustible release of energy; non-powder gun projectiles used with products identified as blow guns, sling shots, cork guns, toy guns, or archery cross bows and other such devices; projectiles designed for adult use in obsolete non-powder guns, custom-made non-powder guns, and non-powder guns designed for and used by law enforcement, scientific, veterinary or military use; paint ball markers, ammunition for airsoft/softair guns and shot used with shotguns in the firearm classification.

1.4 The following precautionary caveat pertains only to the test method portion, Section 7, of this specification: *This standard does not purport to address all of the safety concerns, if any, associated with its use. It is the responsibility of the user of this standard to establish appropriate safety and health practices and determine the applicability of regulatory limitations prior to use.*

### 2. Referenced Documents

2.1 *ASTM Standards*:<sup>2</sup>

F589 Consumer Safety Specification for Non-Powder Guns

### 3. Terminology

3.1 *Definitions of Terms Specific to This Standard:*

#### *Projectiles*

3.1.1 *air-gun dart*—a .177 cal, 5 mm, .22 cal, or .25 cal non-powder gun projectile having a pointed configuration on one end and tufts on the other (see Fig. 1).

3.1.1.1 *tuft*—the material that is added to the body of a dart.

3.1.2 *air-gun shot*—a BB, .177, .22-cal, or .25 cal ball-shaped, non-powder gun projectile made primarily of lead, lead alloy, or steel (see Fig. 2).

3.1.2.1 *air-gun shot, lead*—a shot made of lead or lead alloy which may or may not have a protective finish.

3.1.2.2 *air-gun shot, lead-coated*—a shot made of steel that has a thin, uniform coating of lead or lead alloy. It may or may not have a protective finish.

3.1.2.3 *air-gun shot, steel*—a shot made of steel that is coated with a protective finish.

3.1.2.4 *dimension across flats*—the diameter of an air-gun shot, as measured across the flats.

3.1.2.5 *maximum spherical diameter*—the largest diameter of an air-gun shot, as measured with a ring gage.

3.1.3 *caliber*—the nomenclature used to indicate the bore size of a non-powder gun and the compatible projectile intended for use with that bore size.

3.1.4 *non-powder gun projectile*—a projectile that is designed for and intended to be discharged from a non-powder gun.

3.1.5 *pellet*—a .177 cal, 5 mm, .22 cal, or .25 cal non-spherical, semihollow non-powder gun projectile made of lead, lead alloy, or other material, or a combination thereof. Typical examples are shown in Fig. 3.

3.1.5.1 *nose of pellet*—the forwardmost portion of a pellet.

3.1.5.2 *overall length of pellet*—the maximum dimension of a pellet as measured parallel to the axis.

<sup>1</sup> This consumer safety specification is under the jurisdiction of ASTM Committee F15 on Consumer Products and is the direct responsibility of Subcommittee F15.06 on Safety Standards for Non-Powder Gun Products.

Current edition approved Dec. 1, 2005. Published December 2005. Originally approved in 1978. Last previous edition approved in 2000 as F590 – 92 (2000). DOI: 10.1520/F0590-05.

<sup>2</sup> For referenced ASTM standards, visit the ASTM website, www.astm.org, or contact ASTM Customer Service at service@astm.org. For *Annual Book of ASTM Standards* volume information, refer to the standard's Document Summary page on the ASTM website.

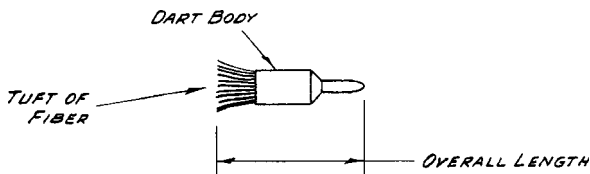

FIG. 1 Air-Gun Dart

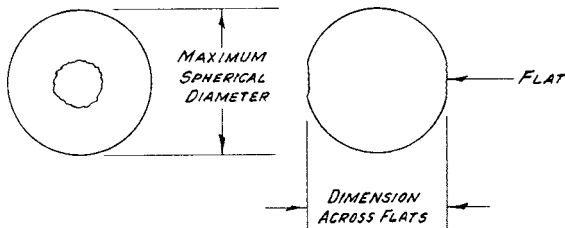

FIG. 2 Air-Gun Shot

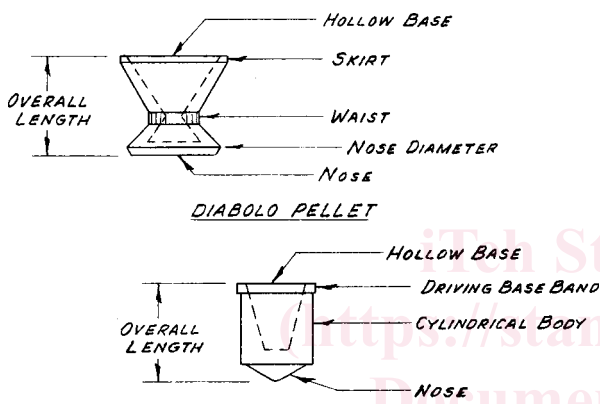

FIG. 3 Air-Gun Pellets

3.1.6 *shot-start force*—the force that is required to insert a non-powder gun projectile into a cavity of standard size for a given caliber.

*Propellants*

3.1.7 *CO<sub>2</sub> (carbon dioxide) cylinder*—a cylinder that holds carbon dioxide in a liquid-gas combination and consists of a main body or container and a neck containing the cap and seal (see Fig. 4) for use in non-powder guns.

3.1.7.1 *cap, CO<sub>2</sub> cylinder*—the section of the cylinder neck containing the seal that is punctured to release CO<sub>2</sub> for use in the non-powder gun.

3.1.7.2 *neck diameter, CO<sub>2</sub> cylinder*—the outside diameter of the neck of a CO<sub>2</sub> cylinder.

3.1.7.3 *neck length, CO<sub>2</sub> cylinder*—the distance the neck of a cylinder enters into a hole equal to the maximum allowable neck diameter (see Fig. 5).

3.1.7.4 *overall length, CO<sub>2</sub> cylinder*—the length measured parallel to the longitudinal axis of the cylinder.

3.1.7.5 *outside diameter, CO<sub>2</sub> cylinder*—the diameter of the main body of the CO<sub>2</sub> cylinder.

3.1.8 *propellant, CO<sub>2</sub> (carbon dioxide)*—a propellant in which the energy source is obtained from compressed carbon dioxide gas.

4. Requirements

4.1 Projectiles:

4.1.1 *Air-Gun Shot, Steel*—Air-gun shot, steel, shall conform to the minimum and maximum diameter dimensions specified in Table 1 when measured in accordance with 7.1 and 7.2.

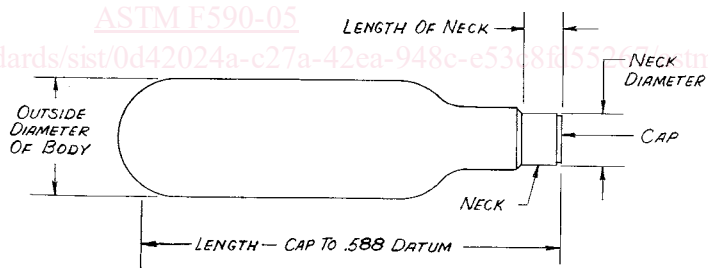

CO<sub>2</sub> (CARBON DIOXIDE) CYLINDER

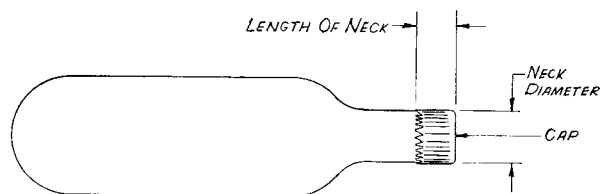

OPTIONAL CAP DESIGN

FIG. 4 CO<sub>2</sub> (Carbon Dioxide) Cylinder

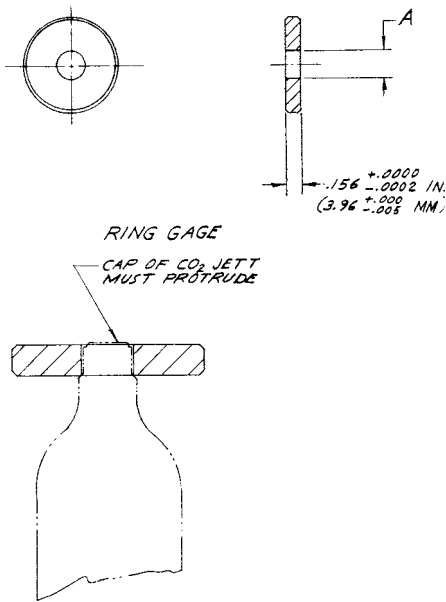

FIG. 5 CO<sub>2</sub> Cylinder Combination Gage (C.R.S.) Maximum Neck Diameter and Minimum Neck Length

TABLE 1 Air-Gun Shot (Steel)—Diameters

Projectile Type	Maximum Spherical Diameter, in. (mm)	Minimum Dimension Across Flats, in. (mm)
Air-gun shot, steel, BB cal (.177 cal)	0.175 (4.44)	0.162 (4.11)
Air-gun shot, steel, .22 cal	0.2198 (5.583)	0.205 (5.21)

4.1.2 *Air-Gun Shot, Lead*—Air-gun shot, lead, shall conform to the minimum diameter dimensions specified in Table 2 when measured in accordance with 7.3 and shall conform to the maximum shot-start force as specified in Table 3 when measured in accordance with 7.4.

4.1.3 *Pellets*—Pellets shall conform to the minimum and maximum length dimensions as specified in Table 4 when measured in accordance with 7.5 and shall conform to the maximum shot-start force as specified in Table 5 when measured in accordance with 7.4.

4.1.4 *Air-Gun Darts*—Air-gun darts shall conform to the minimum and maximum length dimensions as specified in Table 6 when measured in accordance with 7.5 and shall conform to the maximum shot-start force as specified in Table 7 when measured in accordance with 7.4.

4.1.5 *Finish and Appearance*—The outermost surfaces of all projectiles that require protection against deterioration shall have a protective finish.

4.2 *Propellants*—CO<sub>2</sub> gas propellant may be combined with additional ingredients for use as a propellant for non-powder guns, but the propellant shall be noncombustible.

4.3 *Propellant Containers:*

TABLE 2 Air-Gun Shot (Lead)—Diameters

Projectile Type	Minimum Diameter, in. (mm)
Air-gun shot, lead, .177 cal	0.162 (4.11)
Air-gun shot, lead, .22 cal	0.205 (5.21)

4.3.1 *CO<sub>2</sub> Cylinder Measurement Test*—CO<sub>2</sub> cylinders shall conform with the appropriate dimensions and tolerances in Table 8 and Table 9 when measured in accordance with 7.6.

4.3.2 *CO<sub>2</sub> Cylinder Temperature Test*—CO<sub>2</sub> cylinders shall withstand a temperature as defined in 7.6.4.1 without leaking or bursting when tested in accordance with 7.6.

4.3.3 *Rupture Test*—CO<sub>2</sub> cylinders that have been tested in accordance with 7.6 and 7.8 shall not fragment or splinter upon rupture. Failure shall not occur at the cap or neck section of the cylinder.

4.3.4 *Finish and Appearance*—The outermost surfaces of CO<sub>2</sub> cylinders that require protection against deterioration shall have a protective finish.

## 5. Significance and Use

5.1 This consumer safety specification establishes the dimensions and tolerances and supporting test methods for non-powder gun projectiles and propellants to ensure compatibility between the projectiles and propellants and the non-powder guns for which they are designed.

5.2 This consumer safety specification identifies non-powder gun projectiles and propellants and establishes product identification requirements. The product identification requirements are intended to guide users of non-powder guns in selecting the correct projectile or propellant for use in various guns, and attempts to prevent hazards associated with incorrect use of projectiles and propellants.

## 6. Conformance

6.1 Non-powder gun projectiles and propellants produced after the effective date of this consumer safety specification shall not, either by label or other means, indicate conformance with this consumer safety specification unless they conform with all the requirements contained herein.

## 7. Test Methods

NOTE 1—No precision statement on any of the following test methods is available at this time.

7.1 *Measurement of Maximum Spherical Diameter of Air-Gun Shot, Steel* (see Fig. 2 and Table 1):

7.1.1 *Significance*—The purpose of this test method is to establish the maximum diameter of air-gun shot, steel, to ensure that the projectile will be compatible with the non-powder gun for which it is intended.

7.1.2 *Apparatus:*

7.1.2.1 *Ring Gage*, with a minimum thickness of 0.125 in. (3.18 mm) and a hole diameter with the maximum diameter in Table 1 ±0.0001 in. (+0.002 mm). The ring gage is used to determine whether the air-gun shot exceeds the appropriate maximum spherical diameter in Table 1.

7.1.2.2 *Screening Plate* (optional), with holes 0.001 ± 0.0001-in. (0.025 ± 0.002-mm) smaller in diameter than the maximum diameter of the ring gage specified in 7.1.2.1. The screening plate may be used to select or screen only the largest shot for measurement with the ring gage.

7.1.3 *Test Specimen*—Test specimens shall consist of new air-gun shot, selected in accordance with the manufacturer's usual quality assurance practices.

**TABLE 3 Air-Gun Shot (Lead)—Shot-Start Force and Gage Dimensions and Tolerances**

Projectile Type	Maximum Shot-Start Force, lbf (N)	Gage Dimensions and Tolerances (see Fig. 6), in. (mm)		
		Punch Diameter, ±0.001 in. (±0.025 mm)	Inside Diameter, ±0.0001 in. (±0.0025 mm)	Guide Inside Diameter, ±0.001 in. (±0.025 mm)
Air-gun shot, lead, .177 cal	22.5 (100)	0.093 (2.36)	0.175 (4.45)	0.1935 (4.915)
Air-gun shot, lead, .22 cal	20.0 (89)	0.125 (3.18)	0.216 (5.49)	0.234 (5.94)

**TABLE 4 Air-Gun Pellets (Lead)—Maximum and Minimum Lengths**

Projectile Type	Overall Length, in. (mm)	
	max	min
Air-gun pellet, lead, .177 cal	0.260 (6.60)	0.195 (4.96)
Air-gun pellet, lead, 5 mm	0.295 (7.49)	0.225 (5.71)
Air-gun pellet, lead, .22 cal	0.311 (7.90)	0.230 (5.84)
Air-gun pellet, lead, .25 cal	0.433 (11)	0.264 (6.7)

#### 7.1.4 Procedure:

7.1.4.1 Conduct the test at room temperature (60 to 80°F (16 to 27°C)).

7.1.4.2 A screening plate may be used to reduce the number of shot which must be passed through the ring gage. If the screening plate in 7.1.2.2 is used, place the test specimen on the plate. Shake the plate so that the smaller shot pass through the screen and the larger shot remain on the screen. Collect the larger shot remaining on the screen for measurement with the ring gage. Inspect the shot which have passed through the screening plate and sort all abnormal shot from the lot which was passed through the screen for measurement with the ring gage.

7.1.4.3 Place each shot in the hole of the ring gage with the maximum spherical diameter shown in Table 1. Roll the shot in the ring gage so that the diameters of the three perpendicular axes of the shot are exposed to the hole in the ring gage. Shot that does not roll within the ring gage is oversized and fails the test.

#### 7.2 Measurement of Flat Dimensions of Air-Gun Shot, Steel (Fig. 2):

7.2.1 *Significance*—The purpose of this test method is to measure the dimensions across the flats of air-gun shot, steel, to ensure that the shot will be compatible with the gun and the feed system for which it is intended.

##### 7.2.2 Apparatus:

7.2.2.1 *Pointed Micrometer*, capable of measuring with an accuracy of ±0.0001 in. (±0.002 mm).

7.2.3 *Test Specimen*—Test specimens shall consist of new air-gun shot, selected in accordance with the manufacturer's usual quality assurance practices.

NOTE 2—The test specimens used in 7.1 may be used for this test.

##### 7.2.4 Procedure:

7.2.4.1 Conduct the tests at room temperature (60 to 80°F (16 to 27°C)).

7.2.4.2 Measure each shot and record the micrometer reading of the shot from a flat to the opposite surface if one flat exists, or from flat to flat if two flats exist.

7.2.4.3 The shot is acceptable if the diameter measured is equal to or greater than the minimum dimension of the flats specified in Table 1.

#### 7.3 Measurement of Minimum Diameter of Air-Gun Shot, Lead (Table 2):

7.3.1 *Significance*—The purpose of this method is to measure the minimum diameter of air-gun shot, lead, to ensure that the shot will be compatible with the gun and the feed system for which it is intended.

##### 7.3.2 Apparatus:

7.3.2.1 *Micrometer* (0 to 1 in. (0 to 25 mm)), having an accuracy of ±0.0001 in. (±0.002 mm).

7.3.3 *Test Specimen*—Test specimens shall consist of new air-gun shot, selected in accordance with the manufacturer's usual quality assurance practices.

##### 7.3.4 Procedure:

7.3.4.1 Conduct the tests at room temperature (60 to 80°F (16 to 27°C)).

7.3.4.2 Measure the diameter at three different positions. If the shot appears to have a particular diameter or diameters that are smaller than other diameters, then choose the smaller diameters to be measured (such as diameter across one or more flats).

7.3.4.3 The shot is acceptable if all diameters measured are equal to or greater than those specified in Table 2.

#### 7.4 Shot-Start Force Measurement of Air-Gun Shot (Lead), Pellets, and Darts (Table 3, Table 5, and Table 6):

7.4.1 *Significance*—The purpose of this test method is to measure the force required to push an air-gun shot (lead), a pellet, or a dart into a standard size hole that represents the bore of a gun. This procedure is intended to ensure compatibility between projectiles and the non-powder guns for which they are designed.

##### 7.4.2 Apparatus:

7.4.2.1 *Special Shot-Start Force Test Fixture*, as shown in Fig. 6, having gage and punch diameters as provided in Table 3, Table 5, or Table 6, which are appropriate for the projectiles being tested.

7.4.2.2 *Scale*, suitable spring weight having an accuracy of ±0.2 lbf (±0.89 N).

7.4.3 *Test Specimen*—Test specimens shall consist of new air-gun shot (lead), pellets, or darts, selected in accordance with the manufacturer's usual quality assurance practices.

##### 7.4.4 Procedure:

7.4.4.1 Conduct test at room temperature (60 to 80°F (16 to 27°C)).

7.4.4.2 Place a test specimen nose first into the guide section of the shot-start force fixture. Place the punch on the rear of the test specimen and apply force to the punch with the spring scale. Observe the force of the spring scale and record the highest force required to push the test specimen completely into the inside diameter of the gage section of the shot-start force test fixture.